

SPECIFICATIONS

FIGURE 30F
FLEXIBLE CONNECTOR



FLANGED-END METAL BRAIDED FLEXIBLE CONNECTOR

Flexible connectors are used to absorb thermal and seismic movement, absorb hydraulic shock, provide vibration and noise dampening, ease installation, and correct minor misalignment of piping and components. They come in a variety of sizes, materials, and connection ends for numerous applications.

The inner hose is an annular (bellows) design. An annular hose is better suited for pump connections because it can better sustain torsion stress due to longitudinal expansion from rises in pressure. Metal wire braid on a hose assembly restrains against hose elongation under higher pressures and acts to dampen vibration. A heavy braid also increases abrasion resistance. Optimal braid coverage will contain the core under pressure and reduce the possibility of twisting and squirming.

The use of braided metal connectors for applications such as pumps, compressors, and other mechanical equipment can enhance the overall operation of a system.



FEATURES

Braided connectors have the advantages of:

- Longer service life
- Increased pressure capacity
- Greater fatigue resistance due to flex
- Increased temperature capacity of media
- Greater protection of annular hose
- Acceptance of thermal expansion
- NSF 61 compliant (not certified)

REFERENCE CHART

PRESSURE/TEMPERATURE

Item #	Size (in.)	Approx. Wt. (lbs)	Size (in.)	Pressure @ 70°F		Pressure Factors for Above 70°F*			
				Working PSI	Test PSI	°F	Factor	°F	Factor
FNW30FK	2	12	2	455	683	100	0.99	450	0.81
FNW30FL	2-1/2	13	2-1/2	345	518	150	0.96	500	0.79
FNW30FM	3	14	3	290	435	200	0.94	550	0.76
FNW30FP	4	19	4	250	375	250	0.92	600	0.74
FNW30FS	5	27	5	200	300	300	0.89	650	0.72
FNW30FU	6	32	6	210	315	350	0.86	800	0.66
FNW30FX	8	50	8	190	285	400	0.84	1000	0.60
FNW30F10	10	76	10	150	225				
FNW30F12	12	101	12	150	225				

* Multiply working pressure by pressure factor for temperature-adjusted pressure rating.

FIGURE 30F

FLEXIBLE CONNECTOR

FLANGED-END METAL BRAIDED FLEXIBLE CONNECTOR

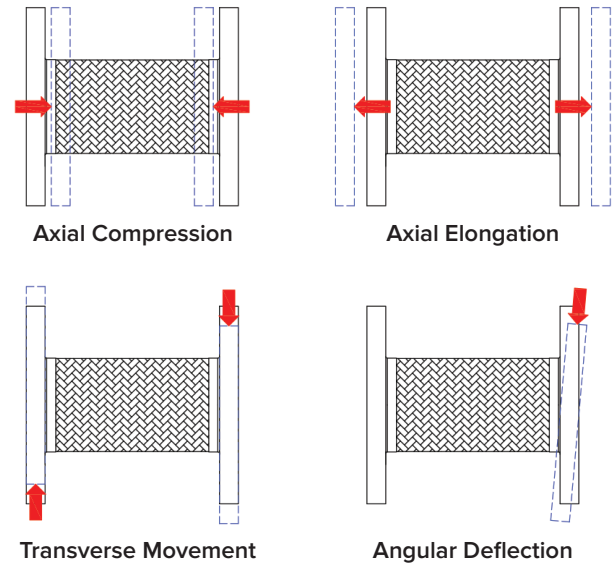
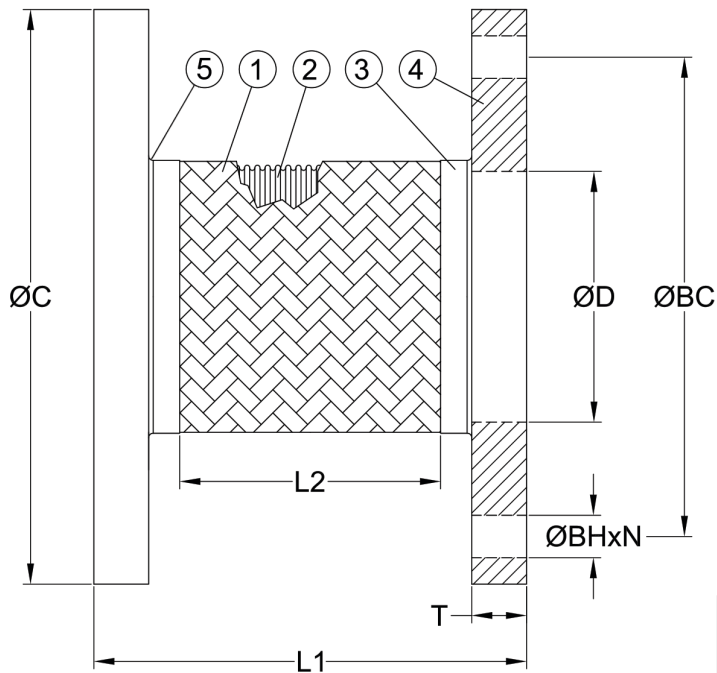

STANDARD MATERIALS

Ref #	Description	Material
1	Hose Braid	304 Stainless Steel
2	Corrugated Hose	321 Stainless Steel
3	Braid Band	304 Stainless Steel
4	Flange	Carbon Steel
5	Welding	Grade er321 Stainless

Size (in.)	Maximum Axial Compression	Maximum Axial Elongation	Maximum Transverse Movement	Maximum Angular Deflection
2	0.16	0.16	±0.12	1.5°
2-1/2	0.16	0.16	±0.12	1.5°
3	0.16	0.16	±0.12	1.5°
4	0.16	0.16	±0.12	1.5°
5	0.20	0.20	±0.16	1°
6	0.20	0.20	±0.16	1°
8	0.20	0.20	±0.16	1°
10	0.20	0.20	±0.16	1°
12	0.20	0.20	±0.16	1°

DIMENSIONS (INCHES)

Size	ØC	ØD	L1	L2 (Min)	ØBC	ØBH	N	T
2	6.0	2.44	9	5.90	4.75	0.75	4	0.63
2-1/2	7.0	2.94	9	5.90	5.50	0.75	4	0.63
3	7.5	3.57	9	5.90	6.00	0.75	4	0.63
4	9.0	4.57	9	5.50	7.50	0.75	8	0.63
5	10.0	5.66	11	7.26	8.50	0.875	8	0.75
6	11.0	6.72	11	7.02	9.50	0.875	8	0.75
8	13.5	8.72	12	7.52	11.75	0.875	8	1.00
10	16.0	10.88	13	8.13	14.25	1.00	12	1.00
12	19.0	12.88	14	8.30	17.00	1.00	12	1.00