

ECCENTRIC PLUG VALVES

CLOW VALVE COMPANY

Size Range	3" – 24"	
Size Range	Water working Pressure psi	Hydrostatic Test psi
3"-12"	175	265
14"-24"	150	225

Available End Connections & Size Range

Flanged
M.J.
Grooved
Flanged – Full Port

3"-24"
3"-24"
3"-16"
3"-12"

Figure No.

F-5412
F-5413
F-5414

Accessories

Floorstands
Extension Stems
Extended Bonnets
2" Sq. Operating Nuts
Handwheels
Lever Wrench Head (3"-8")
Chainwheels
Worm Gear Actuators

Electric Motor Actuators
Cylinder Actuators
Limit Switches
Stem Guides
Floor Boxes
"T" Handles
Chainlevers (3"-8")

* Note: Call Factory For Special Applications

Valves 3" through 8" are available with lever actuators. Geared actuators are recommended on 6" and larger valves. It is also recommended that valves installed in pipelines with high velocity or where water hammer conditions can be caused by sudden valve shut-off that geared actuators be installed. Lever actuators can only be used for pressure ratings of 100 psi maximum and 25 psi in the reverse flow condition.

4"-24" ECCENTRIC PLUG VALVE
MJ Ends with Worm Gear - General Dimensions

CLOW VALVE COMPANY

F-5413

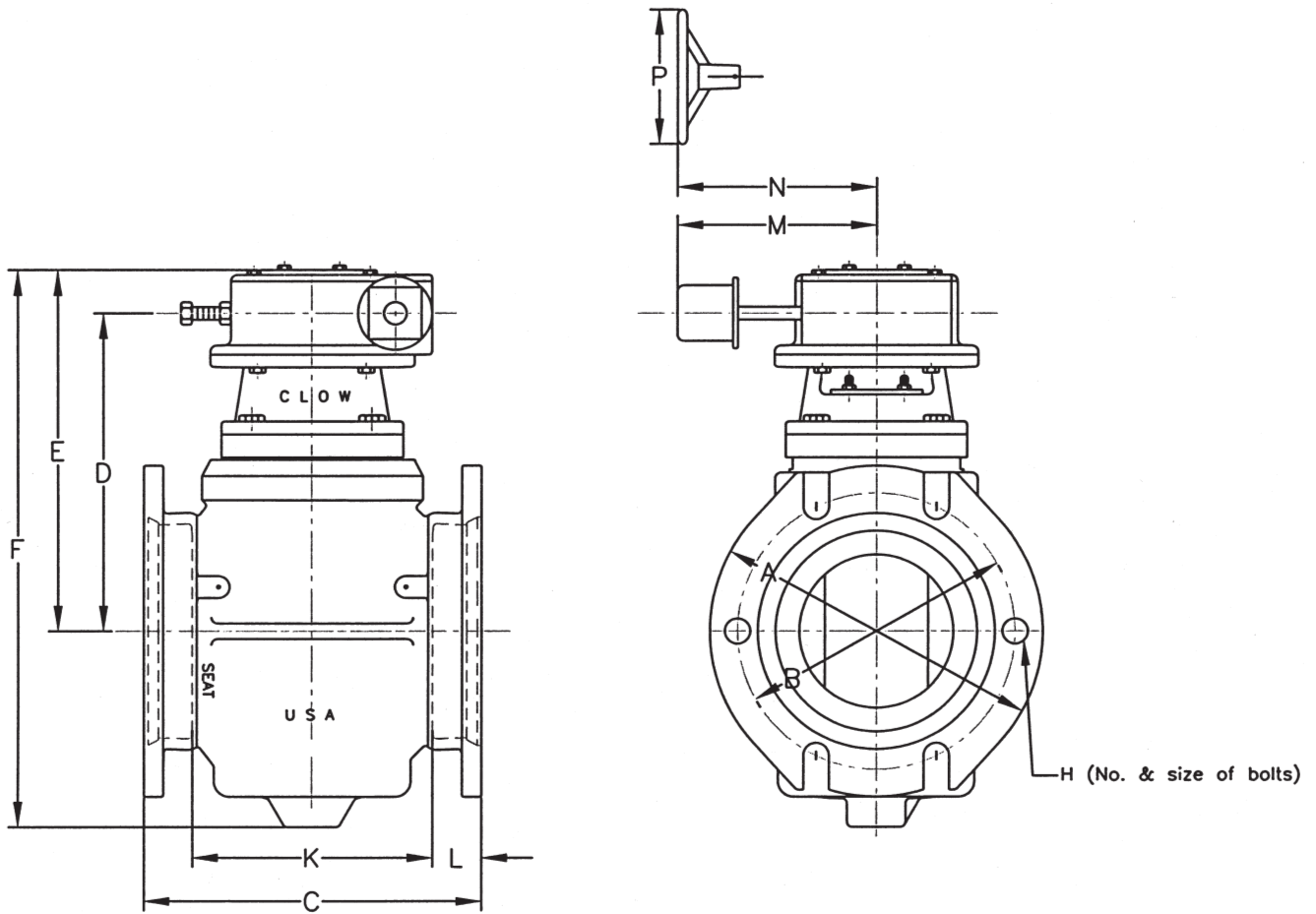

VALVE SIZE	A	B	C	D	E	F	H	K	L	M	R
4"	9 ¹ / ₈	7 ¹ / ₂	12 ¹ / ₄	9 ³ / ₁₆	11 ¹ / ₁₆	16 ⁷ / ₁₆	4- ³ / ₄	7 ¹ / ₄	2 ¹ / ₂	8	3 ¹ / ₄
6"	11 ¹ / ₈	9 ¹ / ₂	15 ³ / ₄	10 ⁷ / ₈	12 ³ / ₄	19 ¹ / ₄	6- ³ / ₄	9 ¹ / ₈	2 ¹ / ₂	8	3 ¹ / ₄
8"	13 ³ / ₄	11 ³ / ₄	17 ¹ / ₂	12 ³ / ₈	14 ¹ / ₄	22 ¹ / ₂	6- ³ / ₄	12 ¹ / ₂	2 ¹ / ₂	8	3 ¹ / ₄
10"	15 ³ / ₄	14	19 ³ / ₈	14 ¹ / ₂	16 ³ / ₈	26 ¹¹ / ₁₆	8- ³ / ₄	14 ³ / ₈	2 ¹ / ₂	8	3 ¹ / ₄
12"	18	16 ¹ / ₄	20 ³ / ₄	16 ¹ / ₁₆	17 ¹⁵ / ₁₆	30	8- ³ / ₄	15 ³ / ₄	2 ¹ / ₂	8	3 ¹ / ₄
14"	20 ⁹ / ₁₆	18 ³ / ₄	24 ¹ / ₂	18 ⁷ / ₈	22 ¹ / ₄	36 ⁹ / ₁₆	10- ³ / ₄	17 ¹ / ₂	3 ¹ / ₂	10	4 ³ / ₄
16"	22 ¹ / ₂	21	24 ³ / ₄	20 ¹ / ₁₆	23 ⁷ / ₁₆	39 ³ / ₁₆	12- ³ / ₄	17 ³ / ₄	3 ¹ / ₂	12	5
18"	24 ³ / ₄	23 ¹ / ₄	28 ⁵ / ₈	22 ¹ / ₈	25 ¹ / ₂	42 ¹¹ / ₁₆	12- ³ / ₄	21 ⁵ / ₈	3 ¹ / ₂	12	5
20"	27	25 ¹ / ₂	30 ³ / ₄	23 ⁷ / ₁₆	26 ¹³ / ₁₆	46 ¹³ / ₁₆	14- ³ / ₄	23 ³ / ₄	3 ¹ / ₂	12	5
24"	31 ¹ / ₂	30	37	25 ¹ / ₁₆	28 ⁷ / ₁₆	51 ³ / ₈	16- ³ / ₄	30	3 ¹ / ₂	12	5

**4"-24" ECCENTRIC PLUG VALVE
Worm Gear Actuator Selection Chart**

CLOW VALVE COMPANY

**Gear operators with 2" sq. operating nuts, 150 ft. - lb. max. input torque
Consult factory for Reverse Flows above 50 psig.**

VALVE SIZE	50 psig	75 psig	100 psig	125 psig	150 psig	175 psig
4"	U10N	U10N	U10N	U10N	U10N	U10N
6"	U10N	U10N	U10N	U10N	U10N	U10N
8"	U10N	U10N	U10N	U10N	U10N	U10N
10"	U10N	U10N	U10N	U10N	U10N	U10N
12"	U10N	U10N	U10N	U70N	U70N	U70N
14"	U90N	U90N	U90N	U90N	U90N	-
16"	U90N	U90N	U90N	U90N	U100N	-
18"	U100N	U100N	U100N	U100N	U100N	-
20"	U100N	U100N	U100N	U100N	U100N	-
24"	U100N	U100N	U100N	U160N	U160N	-

TURNS

U10N = 1KE / OP NUT BURIED SERVICE	10
U70N = 7KE / OP NUT BURIED SERVICE	13.5
U90N = 9KE / OP NUT BURIED SERVICE	16
U100N = 10KE 2.5 / OP NUT BURIED SERVICE	29
U160N = 16KE / OP NUT BURIED SERVICE	90

**Gear operators with Handwheels & 80 lb. max, rim pull
Consult factory for Reverse Flows above 50 psig.**

VALVE SIZE	50 psig	75 psig	100 psig	125 psig	150 psig	175 psig
4"	A110	A110	A110	A110	A110	A110
6"	A110	A110	A110	A110	A110	A110
8"	A110	A110	A110	A110	A110	A110
10"	A118	A118	A118	A118	A118	A118
12"	A118	A118	A118	A718	A718	A718
14"	A924	A924	A924	A924	A930	-
16"	A1024	A1024	A1024	A1024	A1624	-
18"	A1024	A1024	A1024	A1030	A1624	-
20"	A1024	A1024	A1030	A1624	A1624	-
24"	A1024	A1030	A1630	A1630	A1630	-

TURNS

TURNS

A110 = 1KE / 10" HANDWHEEL	10	A930 = 9KE / 30" HANDWHEEL	16
A118 = 1KE / 18" HANDWHEEL	10	A1024 = 10KE 2.5 / 24" HANDWHEEL	29
A718 = 7KE / 18" HANDWHEEL	13.5	A1030 = 10KE 2.5 / 30" HANDWHEEL	29
A924 = 9KE / 24" HANDWHEEL	16	A1630 = 16KE / 30" HANDWHEEL	90