

**8 INCH SHOWN**

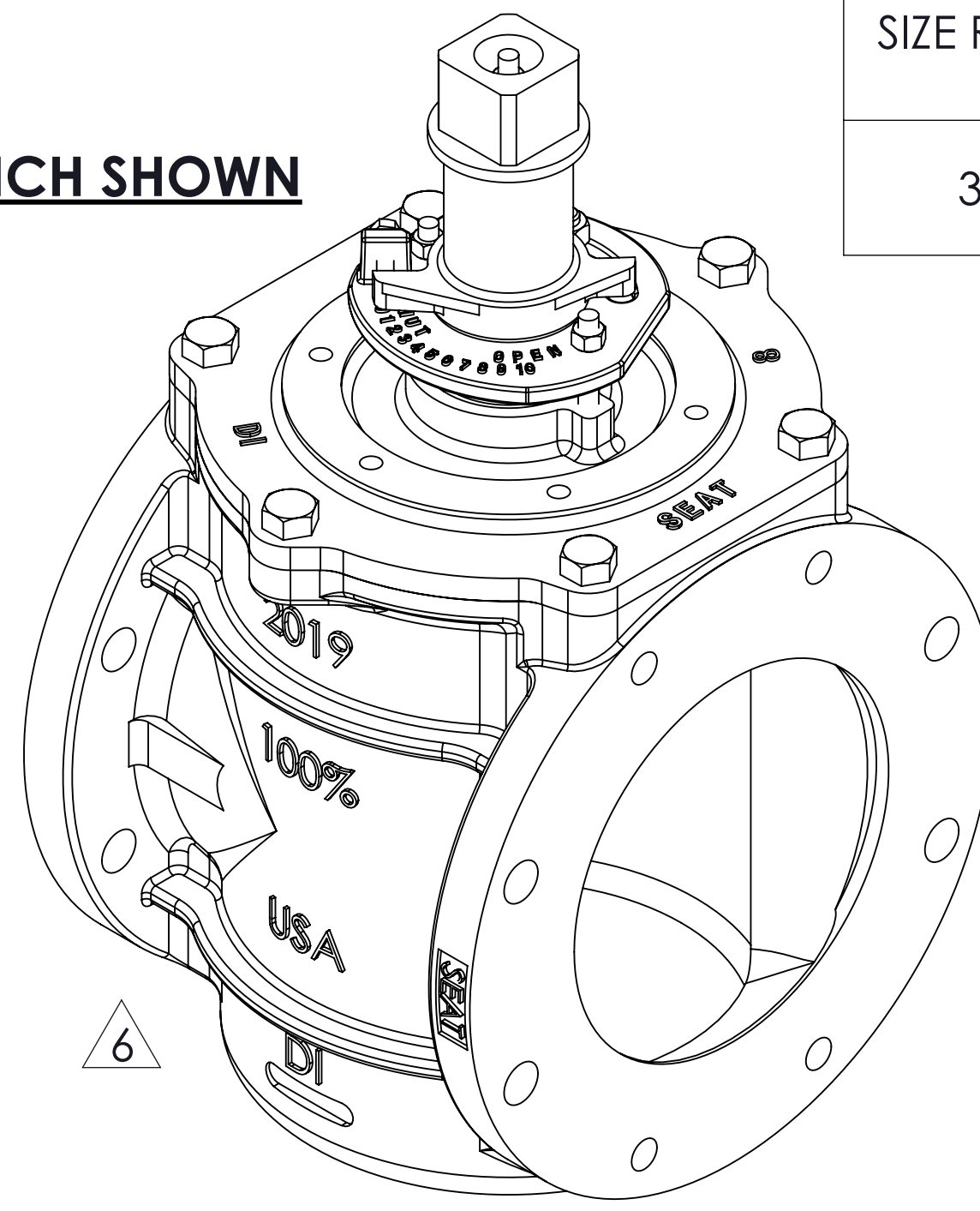

SIZE RANGE	WATER WORKING PRESSURE PSI	HYDROSTATIC TEST PSI
3-12	175 PSI	350 PSI

ITEM#	PART NAME	ASTM/ DESIGNATION	QTY.
1	LOWER SLEEVE BEARING	SINTERED ALLOY SS316	11
2	LOWER GRIT SEAL	NBR	1
3	LOWER THRUST WASHER	PTFE	1
4	PLUG	ASTM A536 GR.65-45-12 or GR.75-50-05 +NBR	1
5	BODY	ASTM A536 GR. 65-45-12 or 70-50-05	1
6	UPPER THRUST WASHER	PTFE	1
7	UPPER GRIT SEAL	NBR	1
8	UPPER SLEEVE BEARING	SINTERED ALLOY SS316	1
9	V-PACKING	NBR	1
10	BRAKE	PPS 40% GLASS FILLED	1
11	COVER STUDS	STAINLESS STEEL ASTM A276.T316	4
12	COVER STUD HEX NUTS	STAINLESS STEEL ASTM A276.T316	2
13	2" SQ. OP-NUT	ASTM A536 GR. 65-45-12 or 70-50-05	1
14	PLUG STEM STUD	STAINLESS STEEL ASTM A276.T316	1
15	HEX LOCKING NUT	STAINLESS STEEL ASTM A276.T316	1
16	DISC SPRING WASHER	STAINLESS STEEL ASTM A276.T316	5
17	COVER	ASTM A536 GR. 65-45-12 or 70-50-05	1
18	COVER O-RING	NBR	1
19	COVER BOLTS	STAINLESS STEEL ASTM A276.T316	4
20	HEX JAM NUT	STAINLESS STEEL ASTM A276.T316	1
21	FOLLOWER SQ. HEAD SET SCREW	STAINLESS STEEL ASTM A276.T316	1
22	SOCKET HEAD CAPSCREW	STAINLESS STEEL ASTM A276.T316	1
23	WASHER	STAINLESS STEEL ASTM A276.T316	1
24	HEX JAM NUT	STAINLESS STEEL ASTM A276.T316	1

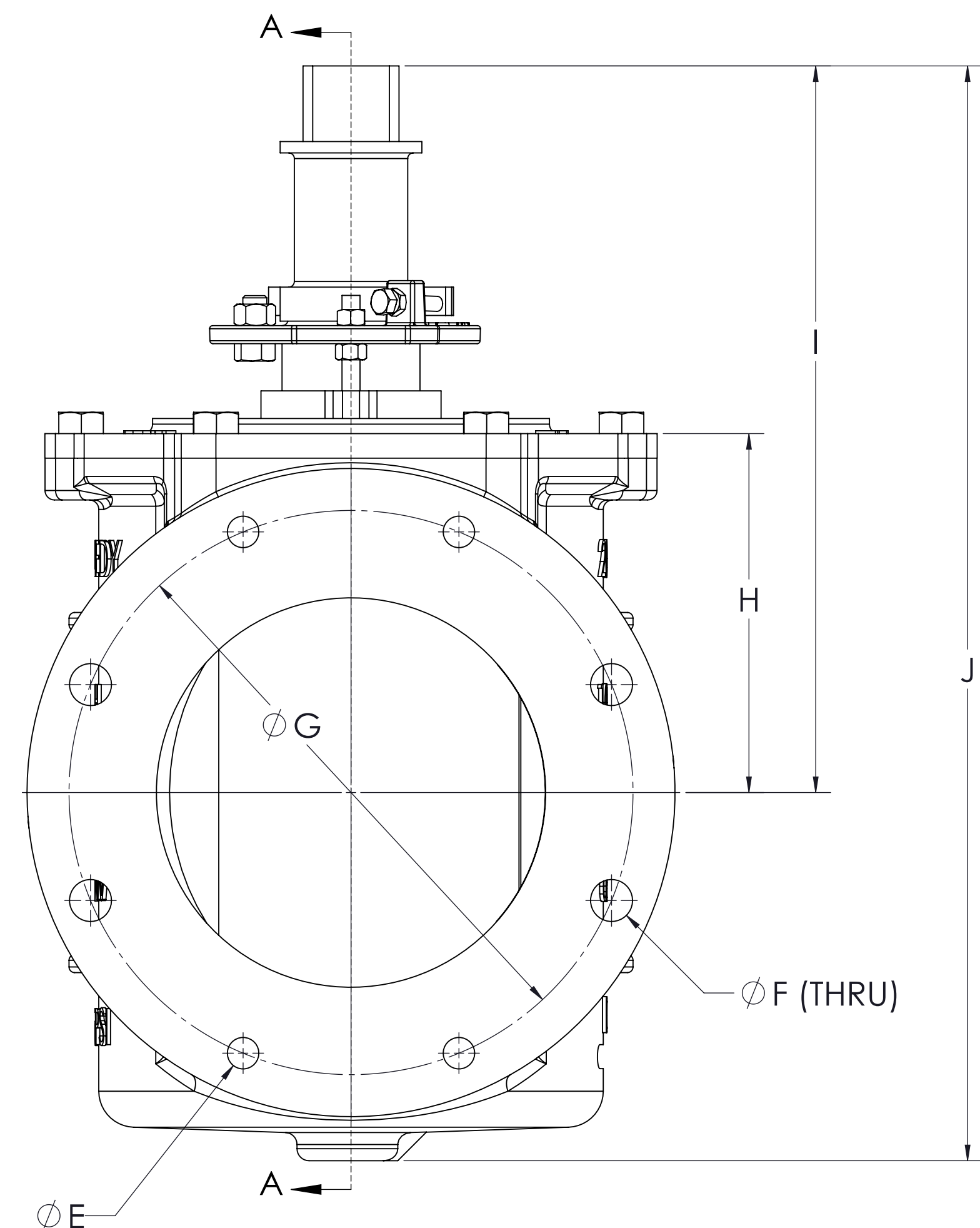
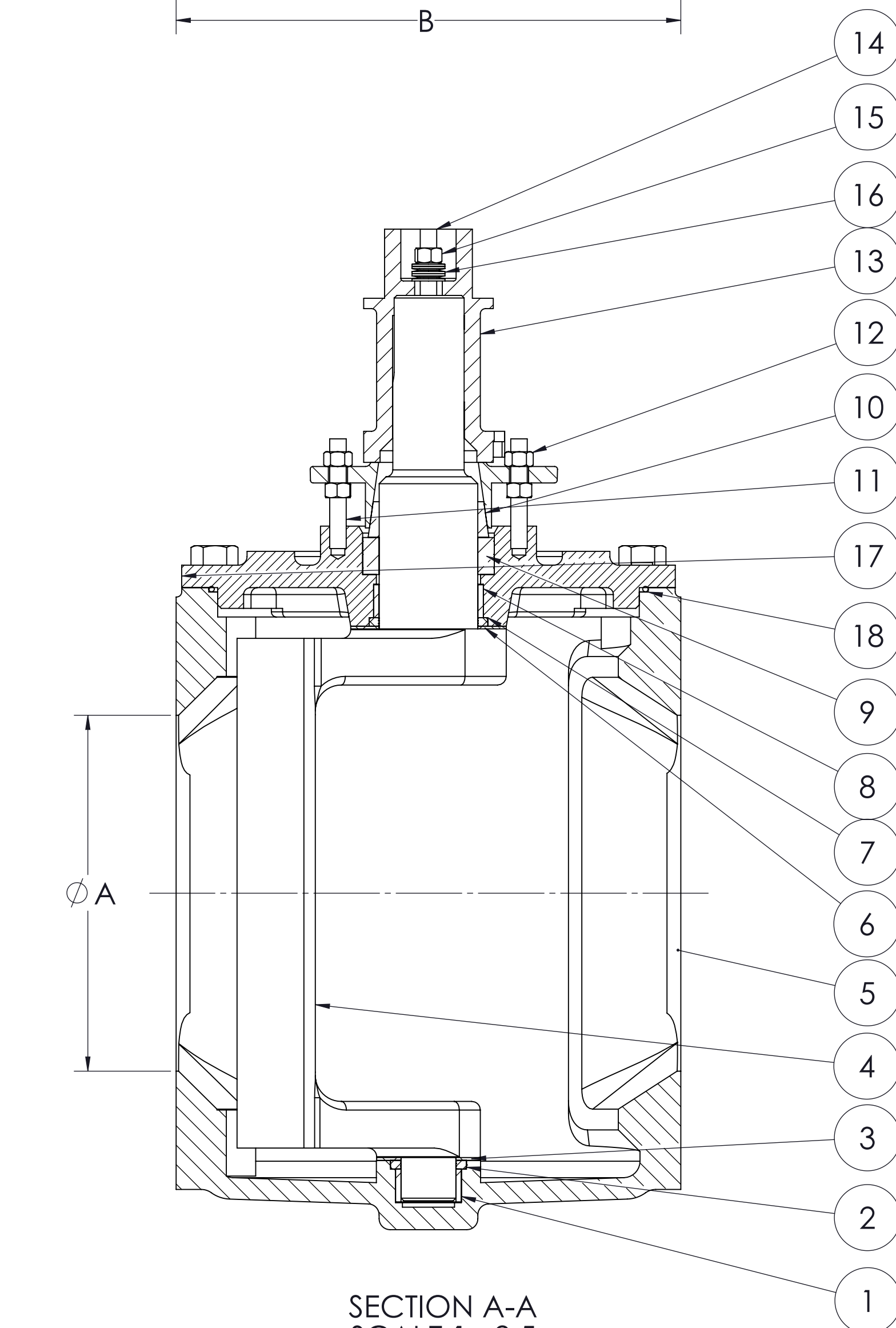

SECTION A-A  
SCALE 1 : 2.5

- NOTE:
- BODY CASTINGS ARE TRI-MARKED WITH "CLOW," "KENNEDY," AND "M&H"
  - 2" OP NUT ACCEPTS STANDARD 2" LEVER/WRENCH
  - FOR SERVICES IN EXCESS OF 25 PSI, USE OF A GEAR IS RECOMMENDED

A [VALVE SIZE]	B	C	D	E	F	G	H	I	J	WEIGHT [LBS.]
3	8.00	.75	7.50	4 x 5/8-11 $\nabla$ .79	-	6.00	3.76	9.38	13.24	50 LBS
4	9.00	.94	9.00	4 x 5/8-11 $\nabla$ .79	4 x .75	7.50	4.65	10.15	14.86	75 LBS
6	10.50	1.02	11.00	4 x 3/4-10 $\nabla$ .79	4 x .81	9.50	5.78	12.96	18.75	125 LBS
8	11.50	1.13	13.50	4 x 3/4-10 $\nabla$ .79	4 x .88	11.75	7.48	15.13	22.79	185 LBS

REVISIONS			
REV.	DESCRIPTION	BY	DATE
2	ADDED 316SS FASTENERS TO BOM AND ADDED NOTE PER CUSTOMER REQUEST	CAW	9/1/2015
3	ATTACHED LEVER	ML	10/8/2015
4	ADDED LEVER OPTION NOTE, PRESSURE NOTE	J CAPPER	7/26/2018
5	MADE FASTENERS 316SS STANDARD, EDITED MARKING NOTE	J CAPPER	2/26/2019
6	UPDATED WITH CORRECT BODY MARKINGS	CAW	3/26/2019

DRAWN	NAME	DATE	 CLOW VALVE CO. Division of McWane, Inc. 902 SOUTH 2ND STREET OSKALOOSA, IA 52577
CHECKED	CAW	7/15/2015	
APPROVED	ML	8/7/2015	
DO NOT SCALE DRAWING			
MATERIAL: SEE TABLE			TITLE:
Weight: SEE TABLE			3"-8" "FULL FLOW" FLG EPV (6412-FF) w/ 2" OP-NUT (LEVER OPTION)
REV. 6			SIZE DWG. NO. SUB910245T
PROPRIETARY AND CONFIDENTIAL			SHEET 1 OF 1