



MARSHALL ENGINEERED PRODUCTS CO.

SPECIALTIES

Float & Thermostatic Trap, Double Inlet/Double Outlet - Series 44 & 45

APPLICATION

The MEPCO Series 44 & 45, Float & Thermostatic Trap with Double Inlet/Double Outlet configuration, is applicable to all types of steam heating systems and steam process equipment. These traps operate efficiently with pressures up to 15 lbs. for lower pressure applications and up to 125 PSI for higher pressure applications. Their purpose is to move air and water while preventing steam from entering the return piping.

These traps are manufactured in four sizes (3/4", 1", 1-1/4" & 1-1/2") for handling capacities of 300 to 4,300 lbs. of condensate per hour. Four (4) possible connections allow a greater flexibility in piping. These traps can be piped in and out from either side, for a total of four piping combinations depending on your particular needs. All working parts are made of non-corrosive metals especially adapted for this service, and each trap is individually tested for reliable operation.

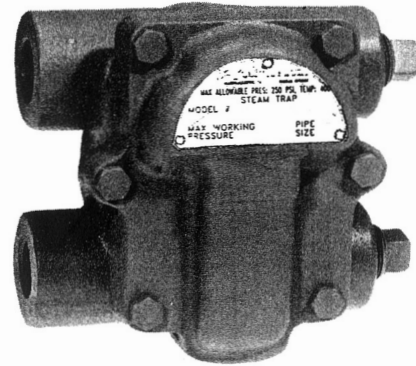

Series 44 Float & Thermostatic Trap (Double Inlet/Double Outlet)

FEATURES & BENEFITS

- 1. Simple, rugged construction.** This *MEPCO* trap consists of a body, cover and float valve assembly. Body and cover are cast iron; all working parts are made of non-corrosive metals especially adapted for this service.
- 2. Sensitive thermostatic action.** Charging the thermostatic disc under high vacuum assures sensitive and positive response to temperature and pressure over entire operating range. Disc corrugations are shaped to reduce hinge action at the rim of the disc and evenly distribute disc motion.
- 3. Instantaneous valve action.** Design of the float valve assembly permits rapid and positive valve action.

Location of the valve assures a deep water seal at all times.

- 4. Continuous rapid flow of water.** A lever operated discharge valve opens wide so that large volumes of water can flow continuously from trap.
- 5. Thorough testing.** In addition to tests made of the completed trap, each thermostatic disc is tested before it is assembled into the trap.
- 6. Minimum maintenance.** All working parts may be inspected, removed or repaired without disturbing piping connections. Clean-out plug at bottom of trap body permits easy flushing of dirt.

PARTS/MATERIALS - 44 & 45 series traps

ITEM	PART	MATERIAL
1	Body	Class 30 Cast Iron
2	Cap	Class 30 Cast Iron
3	Disc (series 44)	Stainless Steel & Brass
3	Plug (series 45)	Brass
4	Hinge	Brass
5	Pin, hinge	Stainless Steel
6	Gasket	Non-asbestos Fiber
7	Seat	SST, Brass holder
8	Valve	Stainless Steel
9	Clip	Stainless Steel
10	Lever & Float Assy	Stainless Steel
11	Plug 1/4" NPT	Steel

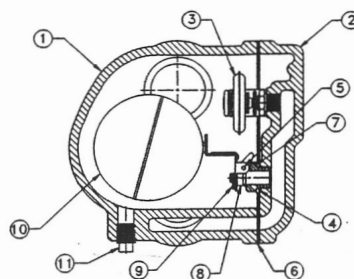

44 SERIES F&T TRAPS ASSEMBLY DRAWING

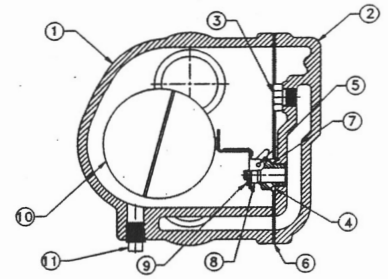

45 SERIES FLOAT TRAPS ASSEMBLY DRAWING

Dimensions and Capacities

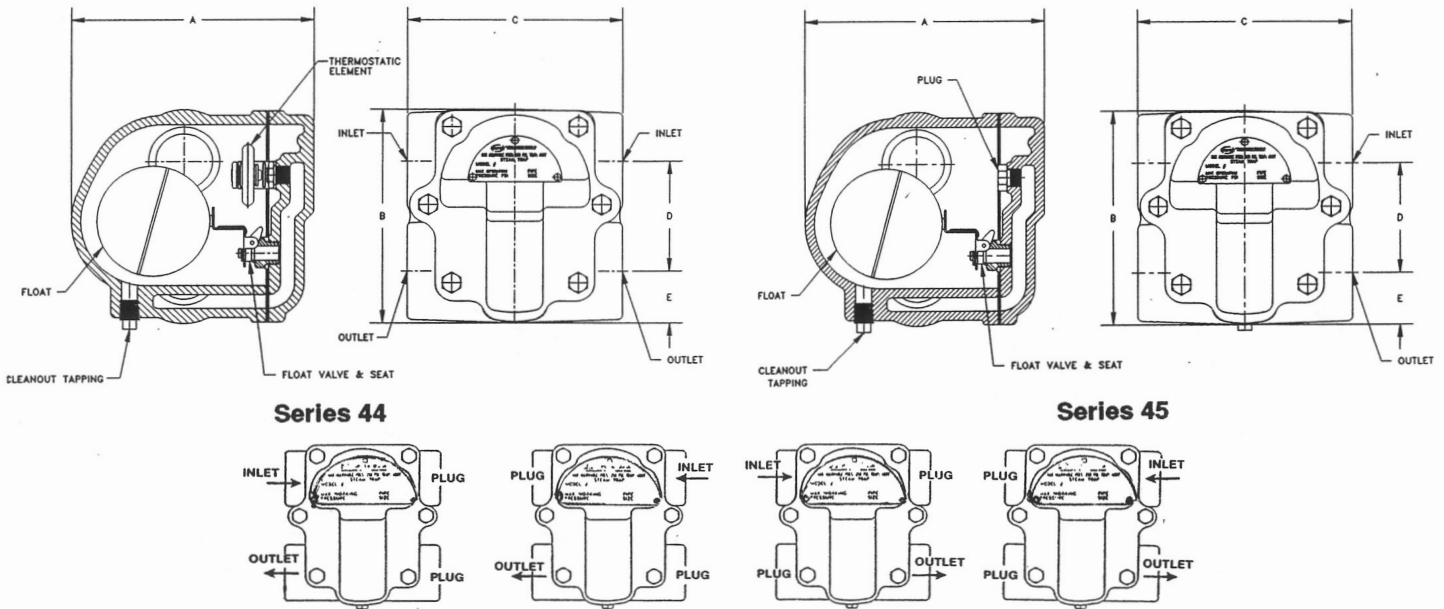

Dimensions

TRAP NO.	TAPPING	A	B	C	D	E	F	G	NET WGT.(lb.)
44/45-2	3/4"	5-3/4	5-11/16	4-7/8	3-3/8	1-5/32	5-13/16	--	12
44/45-4	1"	5-3/4	5-11/16	4-7/8	3-3/8	1-5/32	5-13/16	-	12
44/45-5	1-1/4"	6-3/8	5-3/4	5-3/8	3	1-3/8	6-3/4	--	17
44/45-7	1-1/2"	6-3/8	5-3/4	5-3/8	3	1-3/8	6-3/4	--	17

Capacities

	Model -215A			-230A			-275A			-2125A		
	No. -415A	-515A	-715A	-430A	-530A	-730A	-475A	-575A	-775A	-4125A	-5125A	-7125A
NPT Size	3/4"/1"	1-1/4"	1-1/2"	3/4"/1"	1-1/4"	1-1/2"	3/4"/1"	1-1/4"	1-1/2"	3/4"/1"	1-1/4"	1-1/2"
Orifice	.313	.344	.391	.250	.313	.391	.141	.188	.219	.109	.141	.172
1/4	600	750	980	425	600	800	300	375	400	275	300	350
1/2	825	1,000	1,365	600	825	1,100	375	500	525	310	375	450
1	1,000	1,200	1,855	750	1,000	1,450	425	600	675	350	425	550
2	1,225	1,400	2,410	900	1,225	1,800	500	710	825	390	525	650
5	1,575	1,900	3,150	1,250	1,575	2,400	625	935	1,075	450	625	800
10	1,875	2,300	3,750	1,500	1,875	2,900	725	1,050	1,250	500	725	950
15	2,175	2,700	4,075	1,725	2,175	3,400	825	1,225	1,425	540	825	1,050
20				1,900	2,500	3,750	900	1,375	1,575	600	900	1,150
25				2,050	2,750	4,050	975	1,525	1,725	660	975	1,275
30				2,300	3,000	4,300	1,000	1,675	1,850	725	1,100	1,400
40							1,200	1,825	2,000	850	1,200	1,500
50							1,350	1,950	2,200	1,000	1,350	1,625
60							1,500	2,100	2,400	1,100	1,500	1,780
75							1,650	2,400	2,700	1,280	1,650	1,950
90										1,410	1,825	2,100
100										1,500	1,900	2,275
125										1,650	2,100	2,500

Capacities given are continuous discharge in pounds of condensate per hour at pressure differential indicated, determined by tests conducted according to ASME Performance test Code 39.1-1980. Apply Safety Factor as required per application. Condensate within 5 degrees of steam temperature.

MARSHALL ENGINEERED PRODUCTS CO.

3056 Walker Ridge Drive, Suite C, Grand Rapids, Michigan 49544
 Phone 616.246.1431 Fax 616.246.1445 www.mepcollc.com