

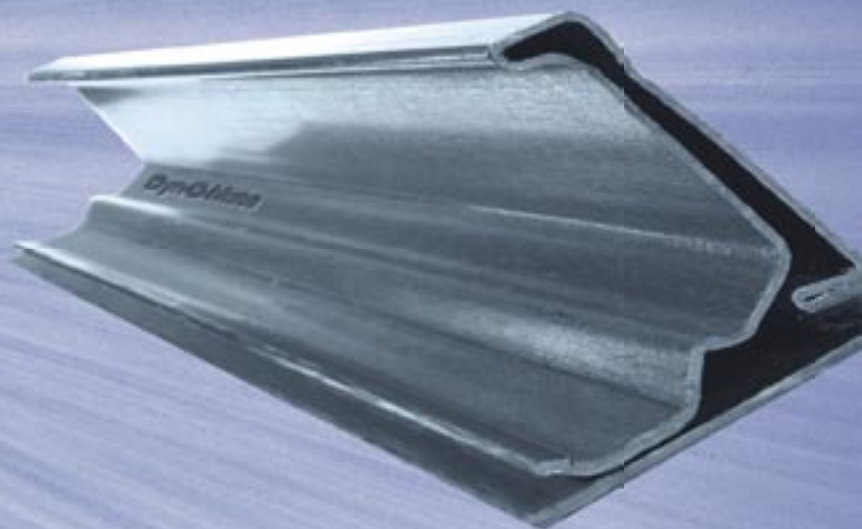

DYNOMATE™

The **ULTIMATE** Flange System



**Product Catalog &
Duct Construction
Standards**



**DURO
DYNE®**

Product Information **DURO DYNE**[®]

Important Ordering Information

- All Dyn-O-Mate Flange, Corners & Cleats are manufactured with yellow label.
- Hollow Turning Vane, Vane Rail, Flat S, Flat Drive, & Standing S are manufactured with yellow label.
- All weights shown in this catalog are approximate.

Product Gauge Identification

- All Flat Drive, Flat S, Flat Hanger Straps and Flange have painted ends to designate the metal gauge color coding is as follows:
 - 16 gauge: Yellow
 - 18 gauge: Black
 - 20 gauge: Blue
 - J Flange: Blue
 - 22 gauge: White
 - 24 gauge: Green
 - 26 gauge: Orange or Red
 - H Flange: White

Warranty

- All Duro Dyne products are warranted against defects in quality or workmanship. Defective material will be repaired or replaced at the manufacturer's option. Liability resulting from defects in quality or workmanship is limited to the value of that material.

Table of Contents

	Page #		Page #
About Duro Dyne	3	Dyn-O-Mate Components	11
Access Doors	8	Flange	4
Assembly Instructions	12-13	Gasket	10
Cleats	5	Butyl	10
Corners	5	Neoprene	10
Duct Construction Standards	15-21	Nosing	6
1/2" W.G. Static	15	Product Information	2
1" W.G. Static	16	Ordering Information	2
2" W.G. Static	17	Product Gauge Identification	2
3" W.G. Static	18	Warranty	2
4" W.G. Static	19	Smacna Policy	14
6" W.G. Static	20	Test Results	22
8" W.G. Static	21	Tool & Accessories	10
Ductwork Connections	7	Crimper	10
Flat Drive	7	Cleat Tool	10
Flat S	7	Injector	10
Standing S	7	Rod Lock	10
Duro Strap	6	Vane and Rail	9
Coiled Hanging Strap	6		
Flat Hanging Strap	6		

Contact Us

DURO DYNE EAST
81 Spence St.
Bay Shore, NY 11706
Tel: (631) 249-9000
Fax: (631) 249-8346
Toll Free: 800-899-3876

DURO DYNE MIDWEST
3825 Symmes Road
Fairfield, OH 45011
Tel: (513) 870-6000
Fax: (513) 870-6005
Toll Free: 800-966-6446

DURO DYNE WEST
15005 Marquardt Ave.
Santa Fe Springs, CA 90670
Tel: (562) 926-1774
Fax: (562) 926-5778
Toll Free: 800-899-3963

DURO DYNE CANADA
5030 Francois-Cusson
Lachine, Quebec
Canada H8T 1B3
Tel: (514) 422-9760
Fax: (514) 636-0328

ABOUT DURO DYNE

Established in 1952, Duro Dyne Corporation has evolved into the leading manufacturer of sheet metal accessories and equipment for the heating, ventilating, and air conditioning industry. Over the span of the last 50 years, Duro Dyne has expanded its plant locations and now employs over 200 people.

Duro Dyne's extensive research and development program has introduced more new products and processes than any other company in our field. Such things as Flexible Duct Connector, as we know it today, as well as Vane Rail and Blade Kits for multi-blade dampers were originally developed and patented by Duro Dyne Corporation. Other products that have now become standards in the sheet metal fabrication field were developed by Duro Dyne Corporation as well. In the fastening field Duro Dyne introduced the concept of self-drilling sheet metal screws. Quieturn Turning Vanes and Glasline Hardware for fiberglass duct systems all were originated by Duro Dyne.

Due to the increasing number of diverse items in our product line, Duro Dyne found it necessary to divide into the Duro Dyne Supply Division, DuroZone Division, Machinery Division, Duro Dyne Tool Division, DynoMate and Dynatite Divisions.

Our Supply Division continues to offer such familiar standards as Flexible Duct Connector, Insulation Fasteners, Screws and Rivets, Adhesives and Sealers, and Air Regulation Hardware. We continue to investigate new and improved solutions for improving shop and field production. Our Spec-Seal Regulators and Side Glide Damper System parts are the latest innovations from this Division.

The DuroZone Division has made dramatic breakthroughs in Zone Control System designs. DuroZone provides cost effective and versatile methods of Zoning for residential and light commercial installation. DuroZone's staff of "in-house" engineers is continually researching the latest technological breakthroughs assuring the best products for today as well as tomorrow's markets.

Duro Dyne's Machinery Division is most noteworthy for the tremendous contribution in the field of insulation fastening...from the first hand held Pinspotter to the FGMH Auto Shift Multi-Head Pinspotter System used by some of the largest contracting shops in the world today. In addition to the finest Pinspotting equipment, Duro Dyne's Machinery Division continues to manufacture the finest Insulation Cutting Equipment, Portable Spotwelders, Water Based Adhesive Application System and Turning Vane Fabricating Equipment. Quality and workmanship have always been of prime importance for the manufacture of our equipment.

The Duro Dyne Tool Division markets the finest quality hand tools for the sheet metal tradesman. In addition to such tools as snips, notchers, crimpers, and seamers, Duro Dyne stocks a full complement of other tools specifically designed for the HVAC industry. Duro Dyne is constantly testing and evaluating new tools for possible addition into our already extensive hand tool line.

Duro Dyne's marketing expertise and Dyn-O-Mate's engineered designs combine to bring the finest 4-bolt duct connection system to the market. In the same vein, our Dyna-Tite Division brings the HVAC Industry an innovative hanging system that eliminates the costly need for threaded rod.

Duro Dyne Corporation does not stop here, for we continue to probe areas in which we could be of greater service. We trust that you will call on us if you have any suggestions as to how we may serve you better.

DURO DYNE CORPORATION



Randall S. Hinden, President

Flange

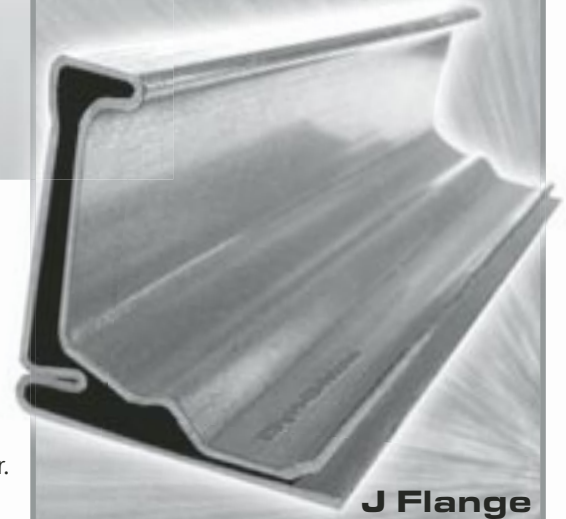
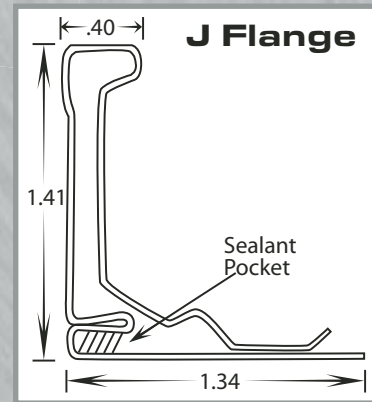

DYN-O-MATE FLANGES

DOMJ Flange

- Designed to strengthen the duct wall and connect duct sections together.
- Furnished with an integrated sealant pocket for a secure air tight fit.
- Manufactured from 20-gauge steel in both 12ft. & 20ft. lengths.
- DOMJ is designed for large commercial and high-pressure applications.
- Available in Aluminum & Stainless Steel.
- Bundles of 20ft. lengths available only with a Full Truckload order.

DOMH Flange

- Designed to strengthen the duct wall and connect duct sections together.
- Furnished with an integrated sealant pocket for a secure air tight fit.
- Manufactured from 22-gauge steel in both 12ft. & 20ft. lengths.
- DOMH is designed for low to medium pressure or residential applications.
- Available in Aluminum & Stainless Steel.
- Bundles of 20ft. lengths available only with a Full Truckload.

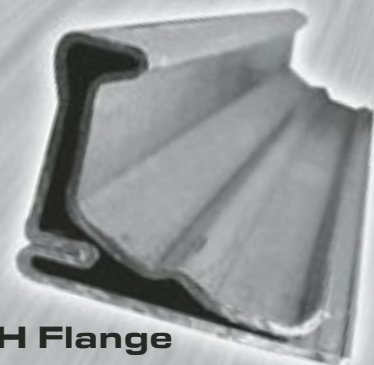
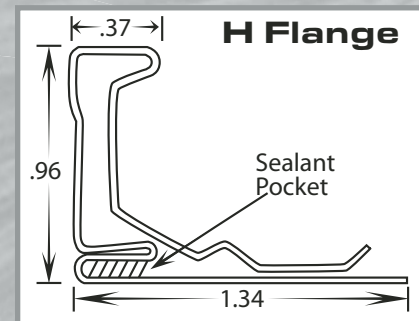

Ordering Information

Item #	Code	Description	Packaging	Weight (lbs.)
21230	DOMJ20	J Flange -20ft.	1000ft./Bundle	740
21231	DOMH20	H Flange-20ft.	1000ft./Bundle	530
21234	DOMJ12	J Flange-12ft.	1200ft./Bundle	890
21235	DOMH12	H Flange -12ft.	1200ft./Bundle	640

Corners & Cleats

DYN-O-MATE CORNERS

- DDJ corners are manufactured from 11-gauge steel. For use with DOMJ Flange.
- DDH corners are manufactured from 12-gauge steel. For use with DOMH Flange.
- DDC and DDF corners are manufactured from 14-gauge steel.
- DDCS (TDC) & DDFS (TDF) corners are for use in corner insertion machines and are manufactured from 16-gauge steel.
- DDJ, DDH, TDC, & TDF corners are available in Aluminum & Stainless Steel.
- Nuts and Bolts for corners are sold separately. (See page 10)

Ordering Information

Item #	Code	Description	Packaging	Weight (lbs.)
21240	DDJ	Corner for DOMJ Flange	250/Box	75
21241	DDH	Corner for DOMH Flange	250/Box	38
21243	DDC	TDC Corner	250/Box	46
21244	DDF	TDF Corner	250/Box	46
21245	DDCS	TDC Stackable Corner	250/Box	35
21246	DDFS	TDF Stackable Corner	250/Box	35

DYN-O-MATE Cleats

- DOM-CLT and DOM-PCLT for use with DOMJ & DOMH 20 gauge flanges for airtight duct connections.
- DOM-CLT and TDF-CLT are manufactured from 20 gauge galvanized steel 6" pieces.
- DOM-PCLT AND TDF-PCLT are extruded .070" PVC and designed for breakaway connection needs.
- TDF-CLT is used with TDF connection.
- TDC-2230 is 22 gauge steel formed into lengths of 30" long and divided into five 6" cleats that are partially cut through allowing them to be easily separated into 6" pieces.

Item #	Code	Description	Packaging	Weight (lbs.)
21250	DOM-CLT	6in. Metal	500/Box (250ft.)	40
21252	DOM-PCLT	6in. Plastic	500/Box (250ft.)	10

TDC/TDF CLEATS Ordering Information

Item #	Code	Description	Packaging	Weight (lbs.)
13230	TDC-2230	6in. TDC (Pre-Scored Cleat)	60-30in. pcs. (150ft.)	33
21251	TDF-CLT	TDF 6in. Metal	500/Box (250ft.)	40
21253	TDF-PCLT	TDF 6in. Plastic	500/Box (250ft.)	10

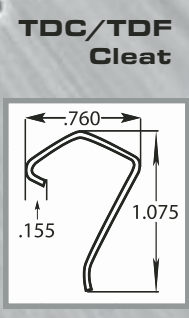
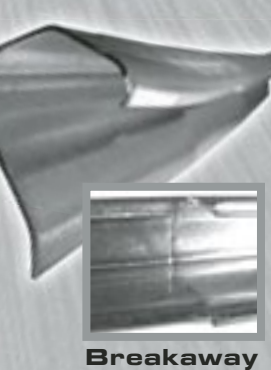
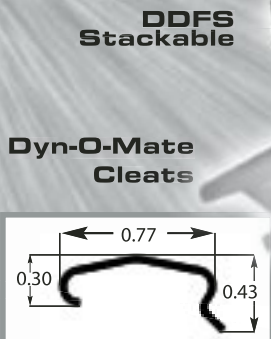
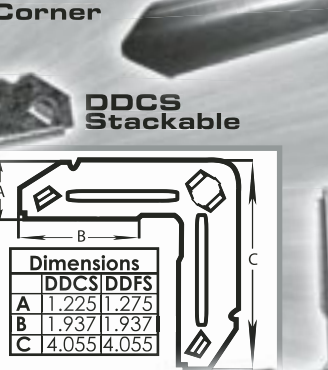
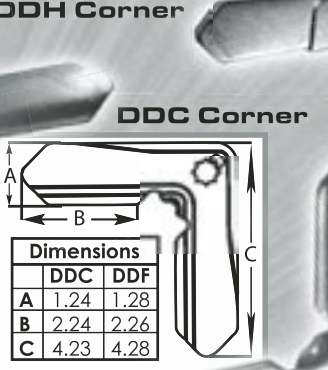
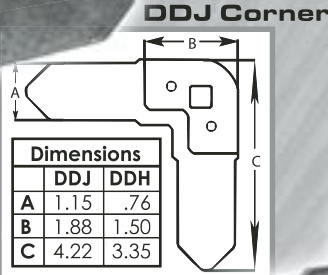
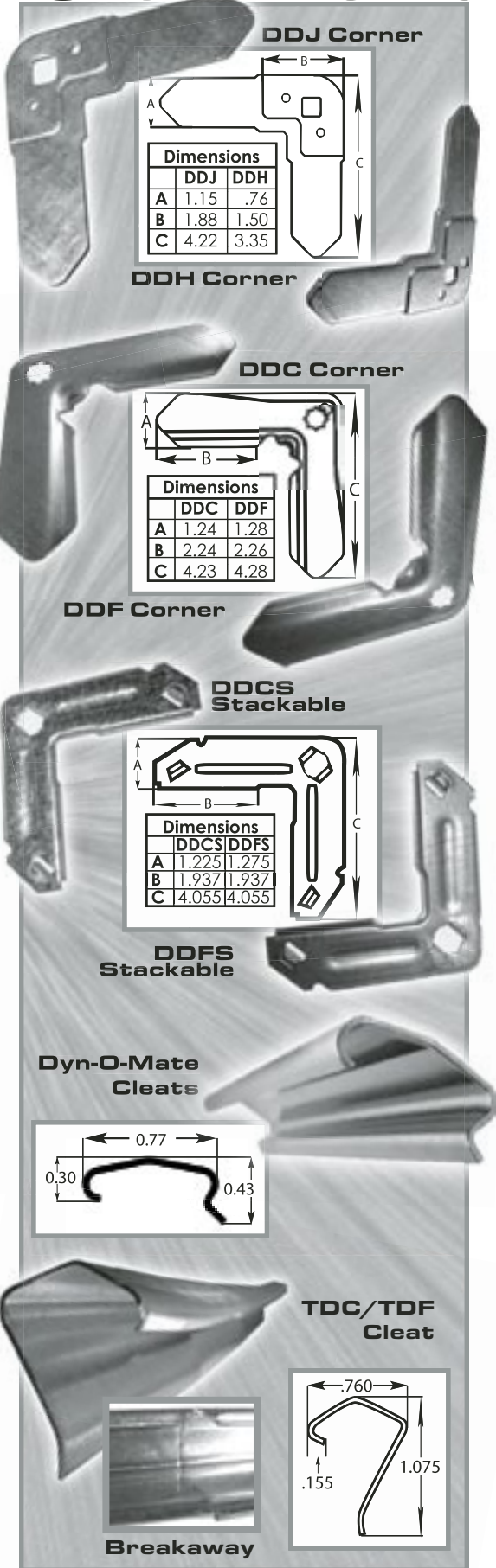

Breakaway

Nosing & Hanging Strap

DYN-O-MATE NOSING

- Protects exposed edge of the duct liner
- Minimizes the possibility of liner delaminating and causing blockage in the ductwork.
- Manufactured from 26-gauge galvanized steel.
- Designed with self adhesive tape for easy installation.
- Available in 1/2", 1", 1 1/2", and 2" height. 10ft. Lengths



Nosing

Ordering Information

Item #	Code	Description	Packaging	Weight (lbs.)
21260	NOS012	1/2 in. Nosing-10ft.	1000ft./Bundle	13
21261	NOS100	1 in. Nosing-10ft.	1000ft./Bundle	16
21262	NOS112	1-1/2 in. Nosing-10ft.	1000ft./Bundle	19
21263	NOS200	2 in. Nosing-10ft.	1000ft./Bundle	23

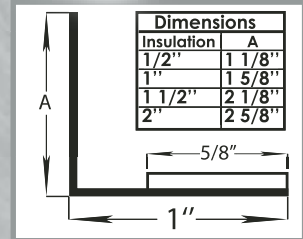

COILED & FLAT GALVANIZED DURO STRAP

- Versatile product used for hanging ductwork.
- Manufactured from 16, 18, 22, and 24 gauge steel.
- Coiled straps make it convenient to carry and easy to cut without wasting material.
- Flat Hanger Strap pre-cut 10ft. lengths.



Coiled Duro Strap

COILED DURO STRAP

Ordering Information

Item #	Code	Description	Packaging	Weight (lbs.)
13250	GS16	16ga. Galvanized Duro Strap-1in.	200ft./Box	44
13251	GS18	18ga. Galvanized Duro Strap-1in.	200ft./Box	36
13252	GS22	22ga. Galvanized Duro Strap-1in.	200ft./Box	24
13253	GS24	24ga. Galvanized Duro Strap-1in.	200ft./Box	20
13254	GS26	26ga. Galvanized Duro Strap-1in.	200ft./Box	20

Flat Hanging Strap

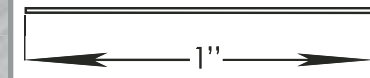

FLAT 10FT. HANGING STRAP

Ordering Information

Item #	Code	Description	Packaging	Weight (lbs.)
13270	HS1610	16ga. Galvanized Hanging Strap-1in.	10-10ft. pcs./Bundle	22
13271	HS1810	18ga. Galvanized Hanging Strap-1in.	10-10ft. pcs./Bundle	18
13272	HS2210	22ga. Galvanized Hanging Strap-1in.	10-10ft. pcs./Bundle	12
13273	HS2410	24ga. Galvanized Duro Strap-1in.	10-10ft. pcs./Bundle	10

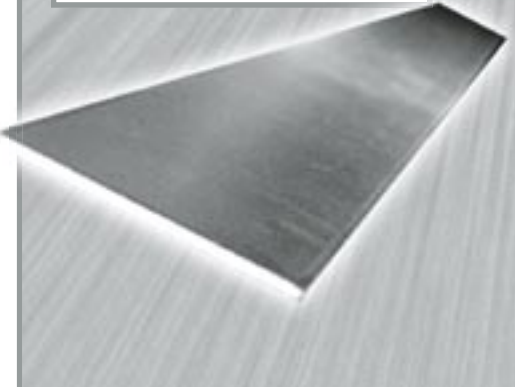

Flat Drive, Flat S & Standing S

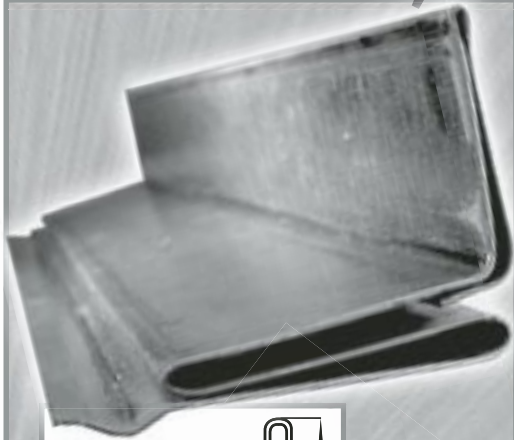

Standing S

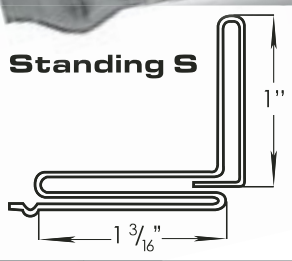

STANDING S LOCK

- Designed to reinforce the connection on the wider ductwork applications.
- Manufactured with 22, 24 or 26 gauge steel, available in 1" widths. (26 gauge is available in both 1" and 1/2")
- Available in 10ft. lengths.

Ordering Information

Item #	Code	Description	Packaging	Weight (lbs.)
13235	SS-2210	22ga. 1in. Standing S 10ft.	10-10ft. pcs./Bundle	69
13214	SS-2410	24ga. 1in. Standing S 10ft.	10-10ft. pcs./Bundle	48
13215	SS-2610	26ga. 1in. Standing S 10ft.	10-10ft. pcs./Bundle	39
13228	SS12-2610	26ga. 1/2in. Standing S 10ft.	10-10ft. pcs./Bundle	20

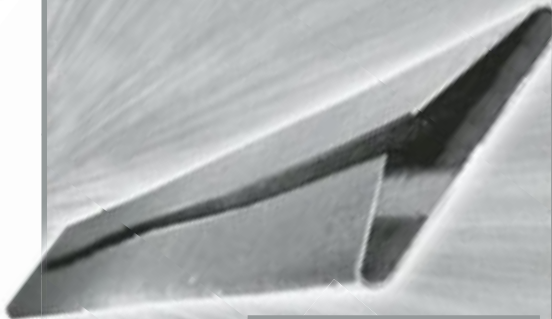

Flat Drive

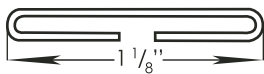

FLAT DRIVE CLEAT

- Designed to secure the connection for lighter ductwork applications.
- Manufactured from 24 and 26 gauge galvanized steel.
- Perfect for lighter gauge and residential ductwork applications
- Tapered ends for an easy start.
- Available in 5ft. or 10ft. lengths.

Ordering Information

Item #	Code	Description	Packaging	Weight (lbs.)
13255	FD-2410	24ga. Flat Drive 10ft.	10-10ft. pcs./Bundle	17
13257	FD-2610	26ga. Flat Drive 10ft.	10-10ft. pcs./Bundle	14
13218	FD-2605	26ga. Flat Drive 5ft.	50-5ft. pcs./Box	34



Flat S Slip

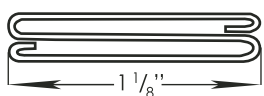

FLAT S LOCK

- Designed to secure the connection for lighter ductwork applications.
- Manufactured from 24 and 26 gauge galvanized steel.
- Available in 5ft. or 10ft. lengths.

Ordering Information

Item #	Code	Description	Packaging	Weight (lbs.)
13256	FS-2410	24ga. Flat S Lock 10ft.	10-10ft. pcs./Bundle	30
13258	FS-2610	26ga. Flat S Lock 10ft.	10-10ft. pcs./Bundle	24
13219	FS-2605	26ga. Flat S Lock 5ft.	50-5ft. pcs./Box	60

Access Doors

Dyn-O-Mate Access Doors

- Available in 10 x 6 and 16 x 12 sizes for rectangular (flat) ductwork, and for round ductwork.
- Round, flat, single and double wall access doors are manufactured from 20-gauge steel.
- Complete with a poly-foam insulation and a closed cell neoprene gasket for an airtight seal.
- Plastic hand knobs insure a quick method removing and reinstalling the access door.

High Temperature Access Doors

- Round and flat High Temperature Access Doors are manufactured from 16 gauge black iron.
- Equipped with steel bolts, compression springs and steel wing nuts for a quick method removing and reinstalling the access door.
- Can be utilized in applications up to 2000 degrees.
- Complete with a ceramic fiber rope gasket.

FLAT ACCESS DOORS

Item #	Code	Door Size	Application	Weight (lbs.)
21173	SWF1006	10 x 6	Single Wall	2
21174	SWF1612	16 x 12	Single Wall	4
21175	DWF1006	10 x 6	Double Wall	3
21176	DWF1612	16 x 12	Double Wall	5
21183	HTF1006	10 x 6	High Temp.	4
21184	HTF1612	16 x 12	High Temp.	6



Flat Access Doors

ROUND ACCESS DOORS

Door Size 16 x 12				Door Size 10 x 6			
Duct Size	2000°F High Temp.	Single Wall	Double Wall	Duct Size	2000°F High Temp.	Single Wall	Double Wall
12"	# 21367 RHT1612-12	# 21340 RSW1612-12		6"	# 21319 RHT1006-06	# 21300 RSW1006-06	
14"	# 21368 RHT1612-14	# 21341 RSW1612-14		8"	# 21320 RHT1006-08	# 21301 RSW1006-08	
16"	# 21369 RHT1612-16	# 21342 RSW1612-16		10"	# 21321 RHT1006-10	# 21302 RSW1006-10	
18"	# 21370 RHT1612-18	# 21343 RSW1612-18	# 21359 RDW1612-18	12"	# 21322 RHT1006-12	# 21303 RSW1006-12	# 21313 RDW1006-12
20"	# 21371 RHT1612-20	# 21344 RSW1612-20		14"	# 21323 RHT1006-14	# 21304 RSW1006-14	# 21314 RDW1006-14
22"	# 21372 RHT1612-22	# 21345 RSW1612-22	# 21360 RDW1612-22	16"	# 21324 RHT1006-16	# 21305 RSW1006-16	# 21315 RDW1006-16
24"	# 21373 RHT1612-24	# 21346 RSW1612-24		18"	# 21325 RHT1006-18	# 21306 RSW1006-18	# 21316 RDW1006-18
26"	# 21374 RHT1612-26	# 21347 RSW1612-26	# 21361 RDW1612-26	20"	# 21326 RHT1006-20	# 21307 RSW1006-20	# 21317 RDW1006-20
28"	# 21375 RHT1612-28	# 21348 RSW1612-28		22"	# 21327 RHT1006-22	# 21308 RSW1006-22	
30"	# 21376 RHT1612-30	# 21349 RSW1612-30	# 21362 RDW1612-30	24"	# 21328 RHT1006-24	# 21309 RSW1006-24	
32"	# 21377 RHT1612-32	# 21350 RSW1612-32		26"	# 21329 RHT1006-26	# 21310 RSW1006-26	
34"	# 21378 RHT1612-34	# 21351 RSW1612-34	# 21363 RDW1612-34	28"	# 21330 RHT1006-28	# 21311 RSW1006-28	
36"	# 21379 RHT1612-36	# 21352 RSW1612-36		30"	# 21331 RHT1006-30	# 21312 RSW1006-30	# 21318 RDW1006-30
38"		# 21353 RSW1612-38	# 21364 RDW1612-38				
40"	# 21380 RHT1612-40	# 21354 RSW1612-40					
42"		# 21355 RSW1612-42	# 21365 RDW1612-42				
44"	# 21381 RHT1612-44	# 21356 RSW1612-44					
46"		# 21357 RSW1612-46	# 21366 RDW1612-46				
48"	# 21382 RHT1612-48	# 21358 RSW1612-48					



High Temp. Access Doors

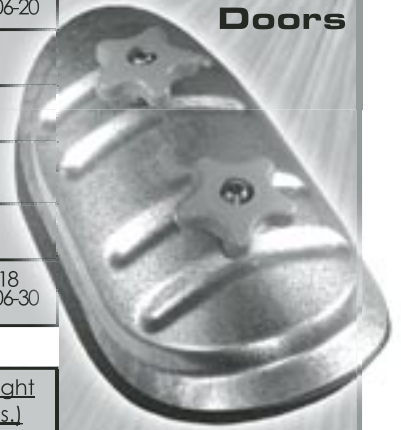

Round Access Doors

Vane and Rail



2" Vane & Rail



4" Vane & Rail

- Hollow Turning Vane and Vane Rail are designed to redirect the air through elbows and tees in the ductwork without significant loss of air pressure. Assembled Vane & Rail minimizes turbulence in the ductwork
- The Vane Rail has self aligning tabs for easy vane installation.
- 2in. Turning Vane are manufactured from 26-gauge galvanized steel.
- 4in. Turning Vane are manufactured from 24-gauge galvanized steel.
- 2 and 4in. Vane Rail are manufactured from 22-gauge galvanized steel.

HOLLOW TURNING VANE

Ordering Information					
Item #	Code	Description	Packaging	Weight (lbs.)	Master Skid Qty.
13203	HTV2-2610	26ga. 2in. Turning Vane 10ft.	10-10ft. pcs./Bundle	45	4200ft.
13220	HTV2-10AL	Alum. 2in. Turning Vane 10ft.	10-10ft. pcs./Bundle	26	4200ft.
13224	HTV2-10SS	Stainless 2in. Turning Vane 10ft.	10-10ft. pcs./Bundle	47	4200ft.
13207	HTV4-2410	24ga. 4in. Turning Vane 10ft.	5-10ft. pcs./Bundle	55	2100ft.
13222	HTV4-10AL	Alum. 4in. Turning Vane 10ft.	5-10ft. pcs./Bundle	33	2100ft.
13226	HTV4-10SS	Stainless 4in. Turning Vane 10ft.	5-10ft. pcs./Bundle	58	2100ft.

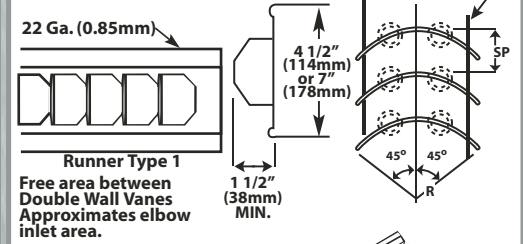
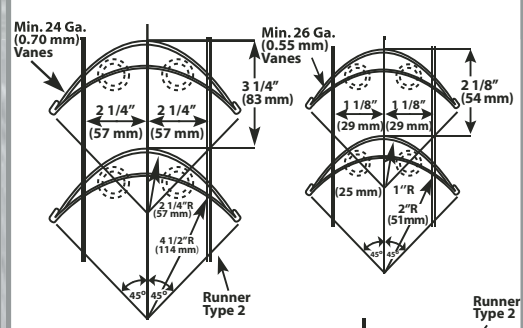

Free area between Double Wall Vanes Approximates elbow inlet area.

Single Vane Schedule			
	R	SP	GA
Small	2" (51mm)	1 1/2" (38mm)	24 (0.70mm)
Large	4 1/2" (114mm)	3 1/4" (83mm)	22 (0.85mm)

See notes on fig.2-4. Other runners may be used as appropriate. Other vane sizes, spacings or configurations are acceptable on designer approval.

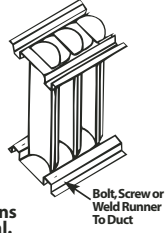

As Described on page 2.5, Figure 2-3 of the SMACNA HVAC Duct Construction Standards, 2nd Ed., 1995.

VANE RAIL

Ordering Information					
Item #	Code	Description	Packaging	Weight (lbs.)	Master Skid Qty.
13204	HVR2-2210	22ga. 2in. Vane Rail 10ft.	10-10ft. pcs./Bundle	46	4000ft.
13221	HVR2-10AL	Alum. 2in. Vane Rail 10ft.	10-10ft. pcs./Bundle	18	4000ft.
13225	HVR2-10SS	Stainless 2in. Vane Rail 10ft.	10-10ft. pcs./Bundle	30	4000ft.
13208	HVR4-2210	22ga. 4in. Vane Rail 10ft.	10-10ft. pcs./Bundle	71	4200ft.
13223	HVR4-10AL	Alum. 4in. Vane Rail 10ft.	10-10ft. pcs./Bundle	36	4200ft.
13227	HVR4-10SS	Stainless 4in. Vane Rail 10ft.	10-10ft. pcs./Bundle	59	4200ft.

Tools and Accessories

THE INJECTOR

For use with the DOMJ & DOMH Flange. The injector easily inserts the corners into the flange two at a time. Adaptable for both the DOMJ & DOMH flange.



Injector

DOMCT CLEAT TOOL

Install the finishing cleat quickly and easily. The tool pulls the duct-work tight while installing the cleat and creating a quick, easy and clean seal on duct connections over 48".



DOMCT Cleat Tool

TDCRMP TDC/TDF CRIMPER TOOL

The Dyn-O-Mate Crimper installs the TDC or TDF corner and crimps the edge over to hold the corner in place.



Crimper

DYN-O-MATE ROD LOCK

Available in 1/2" and 3/4" sizes, tie rods can be used to support duct sizes over 48", quickly and easily. It's as easy to use as a washer, Pull tested to over 1900 lbs., and available in sizes to meet your needs.



Rod Lock

Ordering Information				
-----------------------------	--	--	--	--

Item #	Code	Description	Packaging	Weight (lbs.)
21096	INJECTOR	Pneumatic Corner Injector	1 each	250
21070	DOMCT	DOM Cleat Tool	1 each	1
21072	TDCRMP	TDC/TDF Crimper	1 each	2
21097	DOMRL12	1/2" Rod Lock	250/Box	10
21098	DOMRL34	3/4" Rod Lock	250/Box	10
21060	DOMNB38	3/8 in. Nuts & Bolts	125/Bag	8
21061	DOMNB14	1/4 in. Nuts & Bolts	125/Bag	3

GASKETING

BTL500 Butyl and NEO750 Neoprene Gaskets offer an easy-to-use sealant to provide a moisture and vapor-tight seal to prohibit water and dust from any connection at any atmospheric pressure.

BUTYL GASKET

- Butyl gasket is a permanently soft caulking compound with a high percentage of virgin butyl rubber.
- Butyl gasket can withstand movement without cracking.
- It will adhere to most dry, clean surfaces such as steel, aluminum, plastics, wood and concrete.
- Color: Grey, Black or Off White
- Temperature range: -40°F to 249°F
- Non-Corrosive

NEOPRENE GASKET

- Neoprene gasket tape is a self-adhesive closed cell industrial foam comprised of neoprene, PVC and Nitrile.
- Great for use when connecting ductwork that might periodically have to be taken apart for maintenance purposes.
- Color: Black
- Temperature range: -40°F to 200°F
- Good chemical resistance.



BTL500



NEO750

Ordering Information				
-----------------------------	--	--	--	--

Item #	Code	Description	Packaging	Weight (lbs.)
21042	BTL500	Butyl Gasketing 25ft./Roll	500ft./Box	46
21043	NEO750	Neoprene Gasketing 50ft./Roll	750ft./Box	12
8261	BN316-34	TDC/TDF Neoprene Gasketing 50ft./Roll	1000ft./Box	14

Dyn-O-Mate Components



DYN-O-MATE COMPONENTS

Recommended for 26 ga. through and including 14 ga. ductwork

Flanges

J SYSTEM
 Rollformed from 20 ga. galvanized steel.
 11 Ga. Galvanized Corner

H SYSTEM
 Rollformed from 22 ga. galvanized steel.
 11 Ga. Galvanized Corner

Large sealant pocket on all flange systems

Corners

J CORNER
 11 ga. galvanized steel

H CORNER
 12 ga. galvanized steel

DYN-O-MATE METAL CLEAT

- Roll formed from 20 ga. galvanized steel
- Available in both 6" pieces and 10' lengths
- Suitable for driving in tight installations
- Also available in PVC

Gasketing

SEALANT
 Flame Spread - 5
 Smoke Density - 0
 Fuel Contribution - 0
 Life Expectancy - 20 year minimum

DYN-O-MATE GASKET
 Available in Butyl and Closed Cell Neoprene

<u>BUTYL GASKET</u> Flame Spread - 20 Fuel Contribution - 0 Smoke Density - 0 Thickness - 3/16" Life Expectancy - 20 yr. min. Flash Point - 300° F Compression set - none	<u>NEOPRENE GASKET</u> Flame Spread - 10 Fuel Contribution - 0 Smoke Density - 0 Thickness - 5/16" Unlimited Shelf Life
---	---

Assembly Instructions

DOMJ Flange & DOMH Flange

1. CUTTING THE ANGLE

The angle should be cut $1 \frac{5}{16}$ " shorter than the duct dimensions, cutting the angle with the spine pointing up. Using a chop saw with a 3 h.p. motor and a metal cutting blade helps to insure a clean edge with no burrs.

2. FRAME ASSEMBLY AND SEATING

Using a mallet, insert the corners into the shorter angles; install the larger angles to complete the frame. The raised portion of the corner should be facing inward with the "Dyn-O-Mate" name visible from the outside.

Starting at a corner, use a mallet, hammer the completed frame onto the raw edge of the duct section. Moving in one direction, make sure the duct is seated into the mastic.

NOTE: The duct section should not be notched.

3. FASTENING THE FRAME

The frame can be fastened to the ductwork with either Hex Tex screws (10x3/4) or spot welds.

NOTE: On installations of 3" s.p. or above or on systems where leakage is to be less than 1% spot welding is recommended.

Tek screwing of the angle or spot welding must start within $\frac{3}{4}$ " of each end of the angle at the duct section corners.

(See Chart on Next Page.)

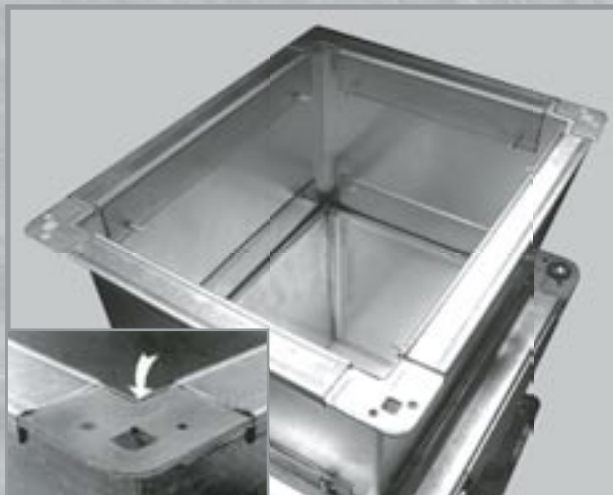

Assembly Instructions

DOMJ Flange & DOMH Flange

STATIC PRESSURE	DUCT SIZE	RECOMMENDED CENTERS
1/2" to 1"	To 48" 49" to 96" Over 96"	At 4 corners & centerline 30" centers 18" centers
1" to 2"	To 42" 43" to 96" Over 96"	At 4 corners & centerline 18" centers 12" centers
2" to 3"	To 36" 37" to 72" Over 72"	At 4 corners & centerline 18" centers 12" centers
3" to 6"	To 24" 25" to 60" Over 60"	At 4 corners & centerline 18" centers 12" centers
Over 6"	To 18" 19" to 48" Over 48"	At 4 corners & centerline 12" centers 8" centers

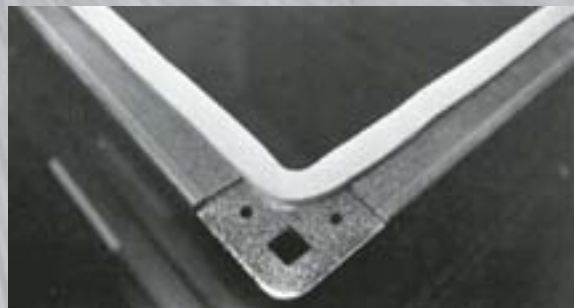

Important: Since sheet metal ductwork installations are sometimes used by the other trades as scaffolding, actual job conditions should really indicate the amount of spot welding and tek screwing.

4. GASKET APPLICATION

Apply a 2 to 3" strip of gasket on the 4 exposed corners of one frame, as pictured.

Starting at the center of the other mating frame, apply a single strap of gasket completely around the inside edge of the frame. **IMPORTANT:** This gasket must also cover the exposed edge of the duct section and the gap between the duct wall and the corner.

NOTE: On installation where the operating pressures are 4" or higher and the leakage requirements are less than 3% special care must be given to the treatment of the corners. Special butyl patches (2"x 3") are available.

5. INSTALLING THE CLEAT

Snap a 6" piece of either metal or PVC cleat over the mating frame, using the following recommendations:

- 1/2" to 2" sp - 1 piece on 24" centers
- 2" to 3" sp - 1 piece on 18" centers
- 4" to 6" sp - 1 piece on 12" centers
- Over 10" sp - continuous cleat



To Whom It May Concern:

SUBJECT: Duct construction other than that in the HVAC-DCS-1985

The foreword of the 1985 HVAC-DCS states that "Although standardization intrinsically involves selection, no intention of discrimination against the use of any product or method that would serve a designer's need equally or better exists." Additionally, recognition of equivalent or other construction is acknowledged in the text as follows:

1. Italicized wording in paragraph one on page 1-12 states "a fifth alternative, that of using non-illustrated construction, is recognized based on sponsor demonstrated equivalency subject to the approval of authorities regulating use of this voluntary acceptance standard. SMACNA does not validate equivalency."
2. Text on page 1-14 states that "certain joints have been assigned maximum pressure classes. Such restrictions are not intended to prohibit consideration of other limits where evidence of acceptability is presented under the equivalent construction principle."
3. Paragraph S 1.18 on page 1-15 states that "Other construction that meets the functional criteria in Section VII or is as serviceable as that produced by the construction tables may be provided."
4. A sentence on page 1-37 says "See Figure 1-4A for commentary on proprietary joint systems and see Section VII for joint performance evaluation."
5. The text on page 1-38 "invites authorities to consider alternative constructions" and says "consult the manufacturers of alternative systems for ratings, assembly requirements and recommendations."
6. Note 3 on page IV states that "the Association refrains from endorsement of proprietary products." Note 4 on this page says "the Association will not review or judge products or components as being in compliance with the document."
7. Paragraph S 3.3 on page 3-2 says "Nothing herein is intended to constitute implied disapproval of the designer's consideration of other methods of construction."
8. Paragraph S 3.26 on page 3-13 states that "Illustrations of accessories and sleeves and collars are representative of a class of such items and are not intended to preclude the use of components not precisely identical to these."
9. Three alternative procedures for rating construction relative to the SMACNA tables are given on page 7-5, analysis, historical track record and testing. Commentary on witnessing tests and on use of test data is provided in the last paragraph on page 7-11, ending with "Authorities are invited to evaluate such construction based on evidence presented by sponsors." Otherwise, the performance criteria used for the SMACNA rectangular duct tables are given in Section VII. General performance requirements are discussed on page 1-3.

We think that these statements from the HVAC-DCS reflect a clear policy of SMACNA's abstention from judging unillustrated components and systems as being equivalent while encouraging consideration of them based on evidence presented by sponsors. Otherwise, SMACNA has not published or authorized any addenda for the 1985 HVAC-DCS.

Sincerely,

John H. Stratton
Director, Technical Services

1/2" W.G.
Static
pos or neg
Duct
Dimen.

SHOP STANDARDS
RECTANGULAR DUCT REINFORCEMENT
Minimum Rigidity Class* - Minimum Gage Duct
Reinforcement Spacing

R=Midpoint Reinforcement
T=Conduit Type Tie Rods
*=These tests were done as comparative tests, and the actual duct deflection was not recorded. They did not exceed SMACNA Deflection Standards.
Note: Two (2) Tie Rods - equally spaced (28" centerline) were used

	8'	6'	5'	4'	3'	2 1/2'	2'						
26" dn	H-26	H-26	H-26	H-26	H-26	H-26	H-26						
27-30"	H-26	H-26	H-26	H-26	H-26	H-26	H-26						
31-36"	H-24	H-26	H-26	H-26	H-26	H-26	H-26						
37-42"	H-24	H-24	H-26	H-26	H-26	H-26	H-26						
43-48"	H-22	H-24	H-26	H-26	H-26	H-26	H-26						
49-54"	H-20	H-22	H-26	H-26	H-26	H-26	H-26						
55-60"	H-20	H-22	H-24	H-24	H-26	H-26	H-26						
61-72"	H-18	H-20	H-22	J26T	H-24	H-24	H-24						
73-84"	J-16	H-18	H-22	J26T	H-24	H-24	H-24						
85-96"	J-16	J-18	J22T	H-20	J22	H-22	H-22						
97-108"			J22T	J-18	J22T	J-18	J22T	H-18	J-22	H-18	J-22	H-18	J22
109-120"			J22T		J22T		J22T	J-18	J22T	H-18	J-22	H-18	J22

When referring to Table 1-3 thru Table 1-10 in the SMACNA HVAC Duct Construction Standards, 2nd ed., 1995,

Use the Dyn-O-Mate "H" Angle on Rigidity Class "F", "G" and "H"
Use the Dyn-O-Mate "J" Angle on Rigidity Classes above "H"

The tables as shown here are the SMACNA Tables with those interpretations already substituted.

These tests results are shown as follows:

SMACNA Table



Variation permitted per certified test.

1" W.G.
Static
pos or neg
Duct
Dimen.

SHOP STANDARDS RECTANGULAR DUCT REINFORCEMENT Minimum Rigidity Class* - Minimum Gage Duct Reinforcement Spacing

R=Midpoint Reinforcement
T=Conduit Type Tie Rods

*=These tests were done as comparative tests, and the actual duct deflection was not recorded. They did not exceed SMACNA Deflection Standards.

Note: Two (2) Tie Rods - equally spaced (28" centerline) were used

	8'	6'	5'	4'	3'	2 1/2'	2'					
14" dn	H-26	H-26	H-26	H-26	H-26	H-26	H-26					
15-20"	H-26	H-26	H-26	H-26	H-26	H-26	H-26					
21-24"	H-24	H-26	H-26	H-26	H-26	H-26	H-26					
25-30"	H-24	H-26	H-26	H-26	H-26	H-26	H-26					
31-36"	H-22	H-24	H-24	H-26	H-26	H-26	H-26					
37-42"	H-20	H-22	H-24	H-26	H-26	H-26	H-26					
43-48"	H-18	H-20	H-22	H-26	H-26	H-26	H-26					
49-54"	H-18	H-20	H-22	J-26	H-24	J-26	H-24	J-26	H-24	J-26	H-24	J-26
55-60"	H-18	H-20	H-22	J-26	H-24	J-26	H-24	J-26	H-24	J-26	H-24	J-26
61-72"		H-18	H-18	J ²⁴ _{26T}	H-22	J26T	H-24	J26T	H-24	J-26	H-24	J-26
73-84"		J-16	J-18	J24T	J-20	J22	H-22	J22	H-22	J-24	H-22	J-24
85-96"			J-16	J-20	J-18	J-20	J-20	J22	H-20	J-22		H-22
97-108"				J22T	J-18	J22T	J-18	J22T	J-18	J-22	J-18	J-22
109-120"				J22T		J22T	J-18	J22T	J-18	J-22	J-18	J-22

* Each duct system shall be constructed for the specific duct pressure classifications shown on the contract drawings for the project. Where no specific duct pressure class designations are provided by the designer the 1" water gage pressure class is the basis of compliance with these standards, regardless of velocity in the duct, except when the duct is variable volume: All variable volume duct upstream of VAV boxes has a 2" w.g. basis of compliance when the designer does not give a pressure class.

*Because total pressure decreases in the direction of the flow a duct construction pressure classification equal to fan outlet pressure (or to fan total static pressure rating) cannot economically be imposed on the entire duct system. Pressure in ducts near room air terminals is nearly always below 1/2" w.g.

*Asterisks indicate wording that is taken directly and verbatim from the SMACNA HVAC Duct Construction Standards, 2nd ed., 1995.

SMACNA TABLE 1-2 DUCT SEALING REQUIREMENTS

Seal Class Class	Sealing Required	Static Pressure Construction Class
A	All transverse joints, longitudinal seams and duct wall penetrations	4" w.g. and up
B	All transverse joints and longitudinal seams	3" w.g.
C	Transverse Joint	2" w.g.

In addition to the above, any variable air volume system duct of 1" and 1/2" w.g. construction class that is up stream of the VAV boxes shall meet Seal Class C.

SHOP STANDARDS
RECTANGULAR DUCT REINFORCEMENT
 Minimum Rigidity Class* - Minimum Gage Duct Reinforcement Spacing

2" W.G.
 Static
 pos or neg
 Duct
 Dimen.

R=Midpoint Reinforcement
 T=Conduit Type Tie Rods

*=These tests were done as comparative tests, and the actual duct deflection was not recorded. They did not exceed SMACNA Deflection Standards.

Note: Two (2) Tie Rods - equally spaced (28" centerline) were used

	8'	6'	5'	4'	3'	2 1/2'	2'
12" dn	H-26	H-26	H-26	H-26	H-26	H-26	H-26
13-18"	H-24	H-24	H-26	H-26	H-26	H-26	H-26
19-26"	H-22	H-24	H-26	H-26	H-26	H-26	H-26
27-30"	H-20	H-22	H-24	H-26	H-26	H-26	H-26
31-36"	H-18	H-20	H-22	H-24	H-26	H-26	H-26
37-42"	H-16	H-18	H-20	H-24	H-24	H-26	H-26
43-48"	J-16	H-18	H-20	H-22	J26T	H-24	H-24
49-54"		J-16	H-18	J 22 26T	H-20	J 22 26T	H-24
55-60"		J-16	J-18	J 22 26T	H-18	J 22 26T	H-24
61-72"			J-16	J24T	J-18	J26T	H-22
73-84"				J22T	J-18	J22T	J-20
85-96"				J22T	J-18	J22T	J-20
97-108"				JT22T	JT22T	K-18	JT22T
109-120"				JT22T	JT22T	JT22T	K-18

Tie Rod Installations
TIE ROD OPTION CONSTRUCTION:

Using the Dyn-O-Mate RODLOCK(Conduit Type Tie Rod) Duro Dyne Corp., through a certified testing Program (in accordance with Chapter 7 of the SMACNA HVAC Duct Construction Standards, 2nd ed. 1995) has used the Conduit Type Tie Rod being attached to the duct wall alone as the reinforcement for the panel tie rod.

Example: 22 T Center tie rod:

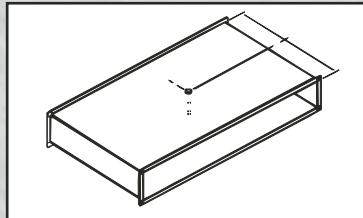

Where the Conduit Type Tie Rod is used as a flange reinforcement, "JT" or "HT", the conduit type tie rod is installed as shown below:

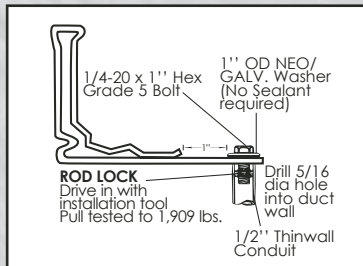

Negative Pressure

NOTE: Do not use internal duct wall supports (tie rods) on negative pressure duct systems without first consulting with the Duro Dyne Corp.

3" W.G.
Static
pos or neg
Duct
Dimen.

SHOP STANDARDS RECTANGULAR DUCT REINFORCEMENT

Minimum Rigidity Class* - Minimum Gage Duct Reinforcement Spacing

R=Midpoint Reinforcement
T=Conduit Type Tie Rods

*=These tests were done as comparative tests, and the actual duct deflection was not recorded. They did not exceed SMACNA Deflection Standards.

Note: Two (2) Tie Rods - equally spaced (28" centerline) were used

	8'	6'	5'	4'	3'	2 1/2'	2'
12" dn	H-24	H-26	H-26		H-26	H-26	H-26
13-18"	H-22	H-24	H-24	H-26	H-26	H-26	H-26
19-22"	H-20	H-22	H-24	H-26	H-24	H-26	H-26
23,24"	H-18	H-22	H-24	H-26	H-24	H-26	H-26
25,26"	H-18	H-22	H-24		H-24	H-26	H-26
27,28"	H-18	H-20	H-22	H-24	H-24	H-26	H-26
29,30"	H-18	H-20	H-22	H-24	H-24		H-26
31-36"	H-16	H-18	H-20	H-24	H-22	H-24	H-24
37-42"		H-18	H-20	H-24	H-22	H-24	H-24
43-48"		J-16	J-18	J26T	H-20	J26T	H-22
49-54"			J-18	J26T	J-18	J26T	H-22
55-60"			J-16	J24T	J-18	J24T	H-20
61-72"			J24T	J-16	J24T	J-20	J24T
73-84"			J20T		J20T	J-18	J20T
85-96"			JT20T		JT20T	K-18	JT20T
97-108"			JT20T		JT20T	JT20T	L-18
109-120"			JT20T		JT20T	JT20T	L-18

This table shows some typical duct sizes and the weight that can be saved by changing gage per certified test:

SMACNA Table



Variation permitted per certified test.

Duct Size	Sq. Ft. per 5' Sect.	Lbs./Sq. Ft.	Lbs./Sq. Ft.	Lbs./Sq. Ft.	Lbs./Sq. Ft.	Lbs./Sq. Ft.
		.91	1.16	1.41	1.66	2.16
		26 ga.	24 ga.	22 ga.	20 ga.	18 ga.
30/18	40	40	51	62	73	95
36/24	50	50	64	76	83	119
42/24	55	55	70	85	100	131
48/24	60	60	76	93	110	143
54/24	65	65	83	101	119	154
60/30	75	75	96	116	137	178
72/36	90	90	115	140	164	214
84/48	110	110	140	171	201	261
96/48	120	120	153	186	219	285

SHOP STANDARDS
RECTANGULAR DUCT REINFORCEMENT
 Minimum Rigidity Class* - Minimum Gage Duct Reinforcement Spacing

4" W.G.
 Static
 pos or neg
 Duct
 Dimen.

R=Midpoint Reinforcement
 T=Conduit Type Tie Rods

*=These tests were done as comparative tests, and the actual duct deflection was not recorded. They did not exceed SMACNA Deflection Standards.

Note: Two (2) Tie Rods - equally spaced (28" centerline) were used

	8'	6'	5'	4'	3'	2 1/2'	2'
10" dn	H-22	H-26	H-26	H-26	H-26	H-26	H-26
11,12"	H-22	H-24	H-26	H-26	H-26	H-26	H-26
13,14"	H-22	H-22	H-24	H-26	H-26	H-26	H-26
15,16"	H-20	H-22	H-24	H-26	H-26	H-26	H-26
17-20"	H-20	H-22	H-24	H-24	H-26	H-26	H-26
21,22"	H-18	H-20	H-24	H-24	H-26	H-26	H-26
23,26"	H-18	H-20	H-22	H-24	H-24	H-26	H-26
27-30"	H-18	H-18	H-22	H-24	H-24	H-24	H-26
31-36"		H-18	H-20	H-22	H-22	H-24	H-26
37-42"		J-16	J-18	H-22	H-20	H-22	H-22
43-48"			J-18	J26T	J-18	J26T	H-22
49-54"			J-16	J24T	J-18	J24T	J-20
55-60"			J-16	J22T	J-16	J22T	J-20
61-72"				J20T		J20T	J-18
73-84"				J20T		J20T	J-20
85-96"				JT20T		JT20T	K-18
97-108"				JT18T		JT18T	L-18
109-120"				JT18T		JT18T	L-18

PRECAUTIONS

In any given duct system, accidental overpressure could occur and must be accounted for by design provisions, such as fail safe features, replaceable release panels and static pressure switches that can shut down the entire system. Note: On all duct systems that are to be tested for leakage, it is recommended that the first 100 feet of completed ductwork be tested before proceeding to complete the installation.

SHIPPING L SHAPED DUCT WITH THE ANGLE INSTALLED

STEP ONE

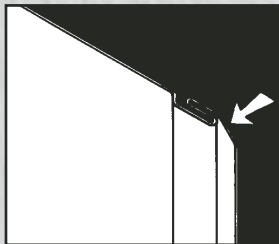

Notch the "hammer edge" of the female Pittsburgh Lock 1/4" on a 45 degree angle as shown.

STEP TWO

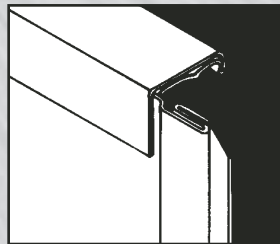

In the shop, install the angle on the duct without the corner piece.

STEP THREE

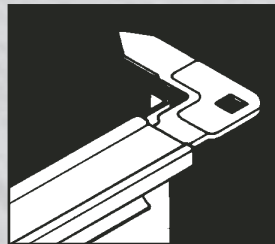

In the field insert a corner piece into the angle at the male end of the Pittsburgh Lock.

STEP FOUR

Complete the frame and bend over the hammer edge of the Pittsburgh Lock in the standard manner.

6" W.G.
Static
pos or neg
Duct
Dimen.

SHOP STANDARDS RECTANGULAR DUCT REINFORCEMENT

Minimum Rigidity Class* - Minimum Gage Duct Reinforcement Spacing

R=Midpoint Reinforcement
T=Conduit Type Tie Rods

*=These tests were done as comparative tests, and the actual duct deflection was not recorded. They did not exceed SMACNA Deflection Standards.

Note: Two (2) Tie Rods - equally spaced (28" centerline) were used

	8'	6'	5'	4'	3'	2 1/2'	2'					
10" dn	H-20	H-22	H-26	H-26	H-26	H-26	H-26					
11,12"	H-20	H-22	H-24	H-24	H-26	H-26	H-26					
13,14"	H-20	H-20	H-22	H-24	H-26	H-26	H-26					
15,18"	H-18	H-20	H-22	H-24	H-26	H-26	H-26					
19-22"	H-18	H-20	H-22	H-24	H-24	H-26	H-26					
23,24"	H-18	H-20	H-22	H-22	H-24	H-26	H-26					
25,28"	H-16	H-18	H-20	H-22	H-24	H-24	H-24					
29-30"		H-18	H-18	H24T	H-22	H-24	H-24					
31-36"		J-16	J-18	H24T	H-20	H-22	H-24					
37-42"			J-16	H24T	J-18	H24T	H-20	H-22	H-24	H-22	H-24	
43-48"				H24T	J-18	H24T	J-18	H-22	J-22	H-24	H-22	H-24
49-54"				J20T	J-16	J20T	J-18	J-20	J-20	J-20	J-22	
55-60"				J20T		H20T	J-18	H20T	J-20	J-20	J-22	
61-72"				JT20T		JT20T	K-16	JT20T	J-18	J-20	J-20	
73-84"				JT20T		JT20T		JT20T	L-16	JT20	K-18	JT20
85-96"				JT18T		JT18T		JT18T	IT16	JT18	L-18	JT18
97-108"				JT18T		JT18T		JT18T	JT16	JT18	L-18	JT18
109-120"				JT18T		JT18T		JT18T	KT16	JT18	KT18	JT18

Dyn-O-Mate Angle as a Breakaway Connection

- A. Dyn-O-Mate frame.
Use neoprene gasket between the frames. Secure duct to sleeve.
- B. Retaining angle, secured to sleeve only.
- C. Fire damper secured to sleeve.
- D. 20 ga. Sleeve up to 54" x 54" - 18 ga. Sleeve 54" and up.
- E. Melt away (200°F) pvc cleat (typ). Install 6" pieces 12" on center starting cleat at extreme end (corners).

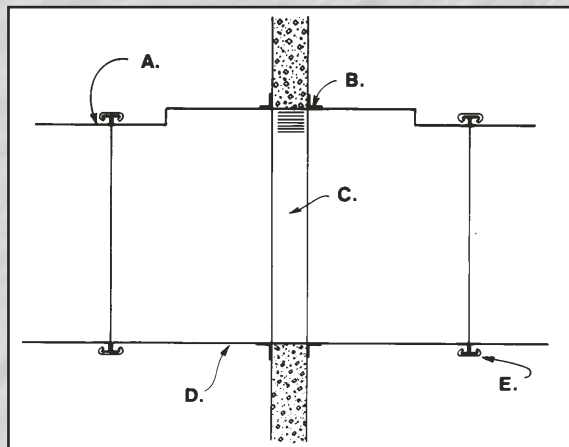

NOTE: Install duct and fire damper sleeve per normal installation procedures with bolts at the corners until all ductwork is installed and testing is completed. After successful testing, the bolts at the corners of the fire damper sleeves are to be removed so as to insure that duct will break away once cleats reach melting temperature of 200 degrees F.

10" W.G.
Static
pos or neg
Duct
Dimen.

SHOP STANDARDS RECTANGULAR DUCT REINFORCEMENT

Minimum Rigidity Class* - Minimum Gage Duct Reinforcement Spacing

R=Midpoint Reinforcement
T=Conduit Type Tie Rods

*=These tests were done as comparative tests, and the actual duct deflection was not recorded. They did not exceed SMACNA Deflection Standards.

Note: Two (2) Tie Rods - equally spaced (28" centerline) were used

	8'	6'	5'	4'	3'	2 1/2'	2'
8" dn	H-20	H-22	H-24	H-24	H-26	H-26	H-26
9",10"	H-20	H-20	H-22	H-24	H-26	H-26	H-26
11",12"	H-18	H-20	H-22	H-24	H-26	H-26	H-26
13",14"	H-18	H-18	H-20	H-22	H-24	H-26	H-26
15-18"	H-16	H-18	H-20	H-20	H-24	H-24	H-26
19",20"	H-16	H-18	H-18	H-20	H-22	H-24	H-24
21-24"		H-18	H-18	H-20	H-22	H-24	H-24
25-28"		J-16	J-18	H-18	H-22	H-24	H-24
29",30"			J-16	J-18	H-22	H-24	H-24
31-36"			J-16	J-18	J-20	H-22	H-24
37-42"			J16T	J-16	J-18	J-20	J-22
43-48"				JT16	J-18	J-18	J-22
49-54"					K-16 JT16	J-18	J-20
55-60"					L-16 JT16	K-18 JT18	J-20
61-72"						L-16 JT16	L-18 JT18
73-84"							LT16 JT16
85-96"							LT16 JT16
97-108"							LT16 JT16
109-120"							LT16 JT16

Compliance to the 1998 California Mechanical Code Addendum.

NOTE:

METAL NOSING MUST BE USED WHEREVER LINER IS PRECEDED BY UNLINED METAL; OTHERWISE WHEN VELOCITY EXCEEDS 4000 FPM (20.3 MPS) USE METAL NOSING ON EVERY LEADING EDGE.

AS DESCRIBED ON PAGE 2.24, FIGURE 2-19 OF THE SMACNA HVAC DUCT CONSTRUCTION STANDARDS, 2ND ED., 1995

← AIR FLOW

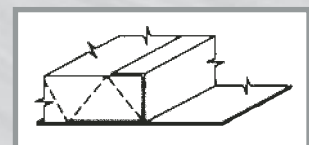

DETAIL A

TEST RESULTS

The following tests of rectangular duct sections and transverse joints were conducted in accordance with Section VII of the SMACNA HVAC Duct Construction Standards, 2nd ed., 1995.

Operating Pressure	Duct Size	Section Length	Duct Gauge	Connector Type	Connector Deflection	Duct Deflection
1"	72/12	60"	18 ga.	H	.249	.650
1"	48/12	60"	26 ga.	H	.050	.750
1"	60/21	60"	26 ga.	J	.060	.750
1"	84/12	60"R	24 ga.	J	.072	.384
1"	96/12	60"	20 ga.	J	.290	.750
1"	84/21	60"T	26 ga.	J	.060	.350
2"	60/21	60"T	26 ga.	J	.050	.010
2"	84/12	48"	18 ga.	J	.250	.740
2"	72/12	60"R	24 ga.	H	.258	.725
2"	72/12	60"	19 ga.	J	.230	.650
2"	48/12	60"	24 ga.	H	.120	.820
2"	84/36	60"R	20 ga.	J	.168	.670
2" see note	84/21	60"T	26 ga.	J	.040	.468
3"	48/12	60"	20 ga.	H	.165	.730
3"	72/12	60"R	24 ga.	J	.140	.702
3"	60/12	60"	18 ga.	J	.131	*
3"	76/44	60"R	20 ga.	J	.220	.500
3"	60/15	60"	16 ga.	H	.148	.740
3"	60/21	60"T	26 ga.	J	.090	.040
4"	72/12	60"R	24 ga.	J	.231	.498
4"	48/12	60"R	24 ga.	H	.164	.498
4"	48/12	60"	20 ga.	H	.245	.830
4"	60/12	60"	18 ga.	J	.160	*
4"	76/44	60"R	20 ga.	J	.278	.600
4"	60/21	60"T	26 ga.	J	.120	.100
5"	48/12	60"R	24 ga.	H	.210	.525
5"	48/12	60"	18 ga.	H	.250	<.750
5"	60/12	60"	18 ga.	J	.211	*
6"	60/12	48"R	20 ga.	H	.215	.730
6"	48/12	60"R	24 ga.	H	.259	.620
6"	48/12	60"	18 ga.	H	.300	.780
6"	60/12	60"	18 ga.	J	.279	*
10"	42/12	48"	16 ga.	H	.200	.730
10"	108/58	60"R	18 ga.	J	.250	<.750
10"	120/42	48"R	16 ga.	J	.100	<.750
10"	42/24	60"R	16 ga.	J	.090	.340

R=Midpoint Reinforcement
T=Conduit Type Tie Rods

*=These tests were done as comparative tests, and the actual duct deflection was not recorded. They did not exceed SMACNA Deflection Standards.

Note: Two (2) Tie Rods - equally spaced (28" centerline) were used

Rectangular Duct Deflection Limits

(As Taken from the SMACNA HVAC Duct Construction Standards, 2nd ed., 1995.)

DUCT WALL	LIMIT
W=12" or less	3/8"
W=13" to 18"	1/2"
W=19" to 24"	5/8"
W=25" to 84"	3/4"
W=85" to 120"	1"
Tolerance of +10%	
JOINTS & REINFORCEMENTS	LIMIT
W=48" or less	1/4"
W=49" to 120"	W/200
Tolerance of 7.5%	

TO PLACE AN ORDER...

Contact The Duro Dyne Sales Office.

23

MAP OF LOCATIONS

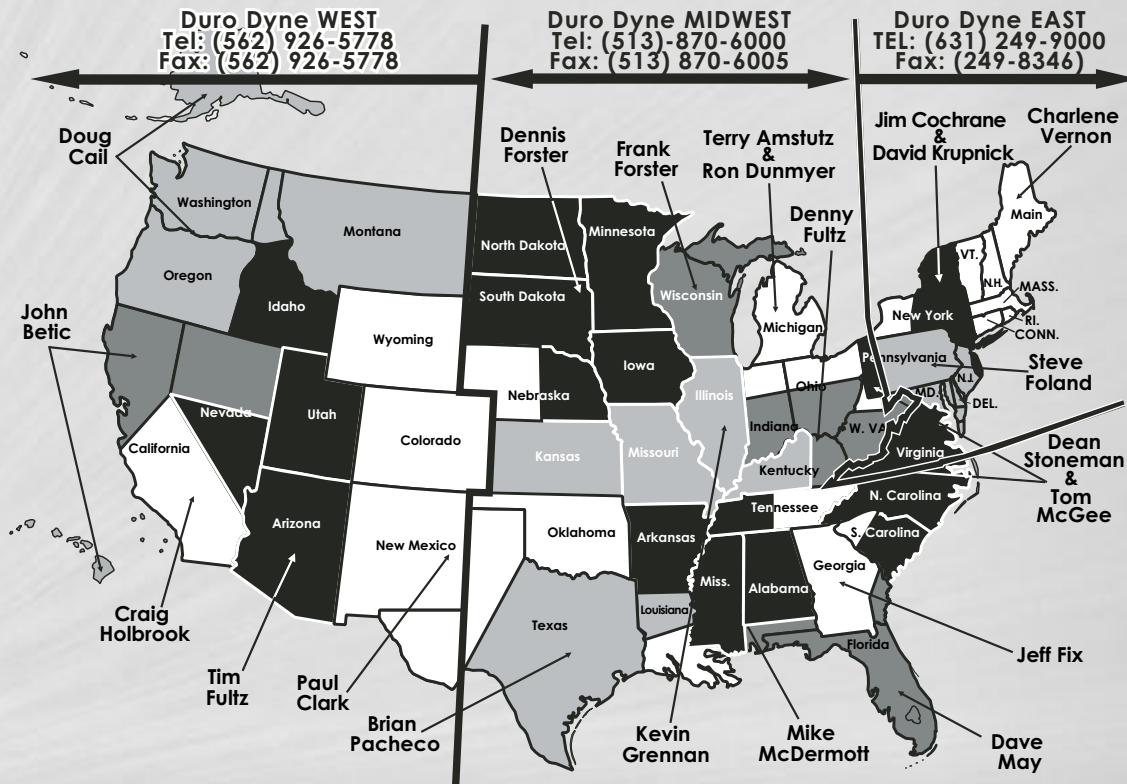

Amstutz, Terry
Indiana
Michigan
Ohio

Betic, John
California
Hawaii
Nevada

Cail, Doug
Alaska
Idaho
Montana
Oregon
Washington

Clark, Paul
Colorado
Nebraska
New Mexico
Oklahoma
Texas
Wyoming

Cochrane, Jim
New Jersey
New York

Dunmyer, Ron
Indiana
Michigan
Ohio

Fix, Jeff
Georgia
South Carolina
Tennessee

Foland, Steve
Delaware
Maryland
New Jersey
Pennsylvania

Forster, Dennis
Iowa
Minnesota
Nebraska
North Dakota
South Dakota

Forster, Frank
Michigan
Wisconsin

Fultz, Denny
Indiana
Kentucky
Ohio
West Virginia

Fultz, Tim
Arizona
Idaho
Nevada
Utah

Grennan, Kevin
Illinois
Kansas
Kentucky
Missouri

Holbrook, Craig
California

Krupnick, David
New Jersey
New York

May, Dave
Alabama
Florida
Georgia

McDermott, Mike
Alabama
Arkansas
Mississippi
Tennessee

McGee, Tom
Pennsylvania
North Carolina
South Carolina
Virginia

Pacheco, Brian
Louisiana
Texas

Stoneman, Dean
Pennsylvania
North Carolina
South Carolina
Virginia

Vernon, Charlene
Connecticut
Maine
Massachusetts
New Hampshire
Rhode Island
Vermont

DYN-O-MATE



©2005 Duro Dyne Corporation
Printed in USA 02/2005
BB021501

Duro Dyne East Division, Bay Shore, NY 631-249-9000 Fax: 631-249-8346
Duro Dyne Midwest Division, Fairfield, OH 513-870-6000 Fax: 513-870-6005
Duro Dyne West Division, Santa Fe Springs, CA 562-926-1774 Fax: 562-926-5778
Duro Dyne Canada, Lachine, Quebec, Canada 514-422-9760 Fax: 514-636-0328
www.durodyne.com E-mail: durodyne@durodyne.com