

# PRODUCT SPECIFICATION DRAWING

## QUICK BELT™ #QB-50-F

### Seismic support for water heaters

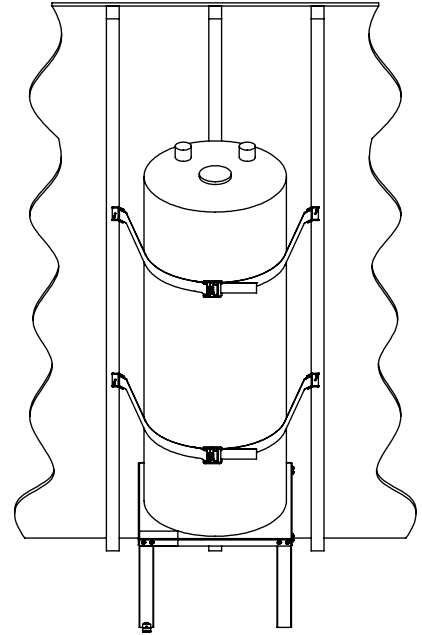
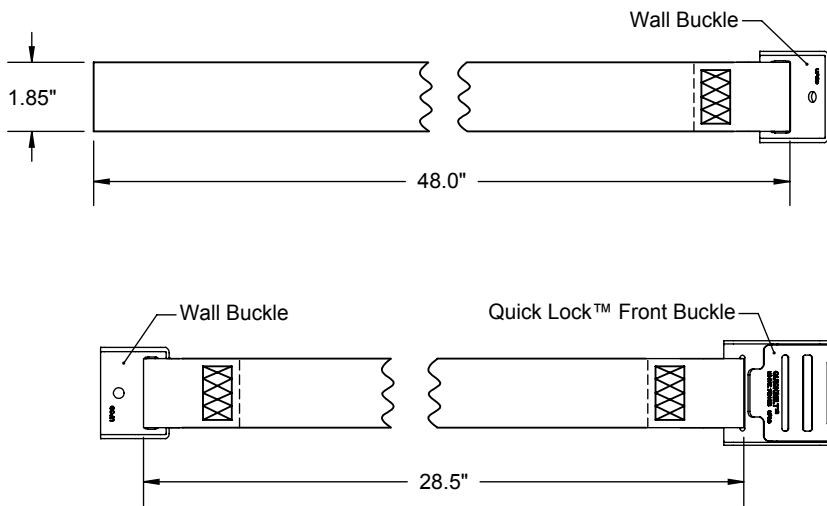

Lag Bolt, #1/4-10 x 2-1/2" Long

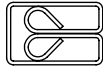

Belt Clip

ALL DIMENSIONS IN INCHES

**The QUICK BELT™ #QB-50-F is a seismic/earthquake support system for water heaters up to 80 U.S. gallons in size. The system includes: (4) Straps, (4) Lag Bolts and (2) Belt Clips. The Quick Lock™ system allows for secure locking of the strap from the front side of the water heater.**

#### Product Information:

- Material:  
 Wall Buckles: 12 gage CRS, galvanized  
 Front Buckle: 14 gage CRS, galvanized  
 Strap: Polyester, medium gray
- Approval: DSA #002-04
- U.S. Patent 7461435
- UPC / IPC / IAPMO listed



THIS INFORMATION IS PROPRIETARY TO HOLDRITE AND IS SUBJECT TO CHANGE WITHOUT NOTICE. IT MAY NOT BE REPRODUCED IN PART OR WHOLE WITHOUT WRITTEN AUTHORIZATION.



CONVERTING MAKESHIFT METHODS INTO ENGINEERED SOLUTIONS<sup>SM</sup>  
 800-321-0316 OR 760-744-6944 / FAX: 760-744-0507 / WWW.HOLDRITE.COM  
 spec\_QB-50-F\_RevH

Product Submittal	
Job Name:	
Date:	
Part Number:	Qty:
Architect / Owner:	
Contractor:	
Notes:	