

# APR5 - ADJUSTABLE POTENTIAL RELAY

## FEATURES:

- Replaces wire by wire virtually any potential relay on the market.
- Recycles instantly.
- Replaces both 5-terminal and 3-terminal potential relays.
- Dimensionally identical to the standard potential relay.
- Universal bracket allows to use the existing mounting of the potential relay being replaced.
- Provides additional protection to the start winding by disconnecting it from power after 0.5 ± 0.1 seconds if the motor does not start. This important safety feature prevents the start winding from overloading during a locked rotor condition.

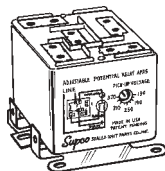

## PICK-UP VOLTAGE

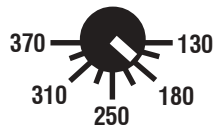

Patent No. 5528120

## INSTALLATION

1. Turn power off.
2. Set the desired Pick-Up Voltage on the APR5 dial.  
If you don't know what the Pick-Up Voltage is, proceed as follows:  
\* For equipment rated for 115-120 volts set the APR5 dial to 180.  
\* For equipment rated for 208-240 volts set the APR5 dial to 310.  
(The above setting will satisfy most motor applications. However, the voltage ranges represent averages that may not be adequate for some applications. It is better to set the Pick-Up Voltage according to the equipment specifications.)
3. Attach all wires from the old relay to the APR5 using the corresponding terminal numbers.

## TYPICAL APR5 WIRING DIAGRAMS

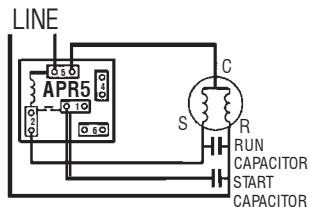

BASIC WIRING

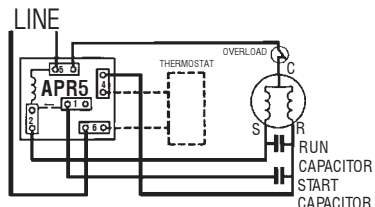

WIRING WITH A THERMOSTAT AND OVERLOAD

## CROSS REFERENCE

APR5 SETTING	APPROX. PICK-UP VOLTAGE	MARS NO.	STEVECO NO.
145	139-153	19002	90-63
270	260-275	19003	90-64
175	168-182	19004	90-65
220	215-225	19005	90-66
310	295-315	19006	90-67
340	325-345	19007	90-68
190	180-195	19008	
300	285-305	19009	90-70
220	212-232	19010	90-71

## IF YOU WISH TO VERIFY THE APR5 SETTING:

1. Place an analog clamp-on ammeter over either one of the two wires from the start capacitor, or the wire from the start winding.
2. Apply power and observe the ammeter.
3. CORRECT SETTINGS: The Pick-Up Voltage is properly set if the relay contacts open when the unit is up to 70%-80% of full speed. Under normal conditions the motor will reach its full speed within 0.1-0.2 seconds. The ammeter cannot react that fast, however you will observe some swing of the needle.
4. If the Pick-Up Voltage is set too high, the voltage on the start winding will not reach the level of the APR5 setting. The needle of the ammeter will swing to its maximum arc and hesitates for 0.5 ± 0.1 seconds before returning to zero. It simply means that the APR5 automatically opened the contacts after the safety time limit. Turn the setting to the next lower mark. Each mark is about 30 volts. Repeat until the motor and APR5 operate as in paragraph 3.
5. If the Pick-Up Voltage is set too low the relay contacts will open before the motor has a chance to get to the full speed. The motor may not start at all. The needle of the ammeter may swing and return to zero too fast. The relay opens the contacts before the motor has a chance to reach the desired speed. Increase the voltage setting by one mark until the relay and motor operates as indicated in paragraph 3.

Supco

SEALED UNIT PARTS CO., INC

PO Box 21 • 2230 Landmark Place • Allenwood, NJ 08720 • www.supco.com

# SUPR UNIVERSAL POTENTIAL RELAY

The SUPR is a potential relay designed to be a wire-by-wire universal replacement for virtually any potential relay on the market. It can be used on any single split phase motor or refrigeration hermetic compressor up to 5 H.P.

## Features:

- Replaces wire-by-wire virtually any potential relay on the market.
- Recycles instantly.
- Replaces both 3 and 5 terminal potential relays
- SUPR has dimensions identical to the industry standard potential relay.
- Universal bracket allows using the existing mounting of the potential relay being replaced.
- Provides additional protection to the start winding by disconnecting it from power after 0.5 seconds if the motor does not start.
- Prevents the start capacitor from venting by disconnecting it from the circuit after 0.5 seconds.

## Specifications:

Operating Voltage:	110-270 VAC, Single Phase
Motor Power Rating:	Up to 5H.P.
Start time:	0.5 +/- 0.1 seconds.
Operating Position:	Non-positional mounting.
Universal Mounting Bracket:	Allows for easy installation. Unused portions of the bracket simply snap-off with pliers.
Terminals:	Screw or Push-on. Adapters to convert screw-on to push-on are provided.

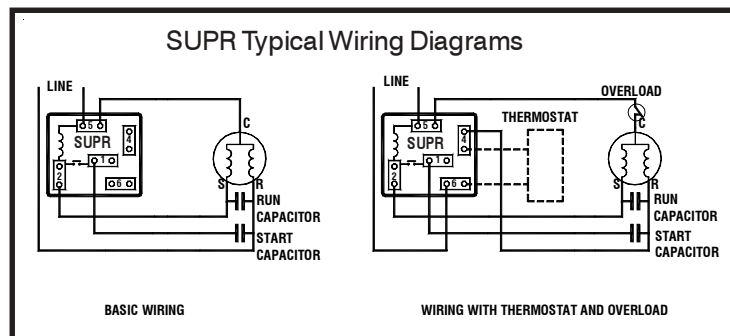

*Supco*

**SEALED UNIT PARTS CO., INC**

PO Box 21 • 2230 Landmark Place • Allenwood, NJ 08720 • [www.supco.com](http://www.supco.com)