

B-TOO™ DRILLING & TAPPING MACHINE



Transmate

a Division of Romac Industries, Inc.

MATERIAL SPECIFICATIONS

- Powered by hand or with Ridgid 690 (11-29)
- High strength, modular aluminum and steel components
- Inserts any 3/4" to 1" corporation stop under pressure
- Extracts threaded corporation stops from the main and inserts a main plug
- Uses Mueller B101 saddles, drill/taps, ratchets, chain holders, chains and screw plugs



3/4" TO 1" RANGE OF CUTS



SHORT COMPACT DESIGN

Provides greater stability when cutting with the drill tap and easier alignment when inserting the corporation stop.

Can be used on water pressures up to 250 psi without additional fittings or components.

ITEM NUMBER	DESCRIPTION	LIST PRICE
356-00	B-Too Tapping Machine for Direct Insertion	\$4,366.81
353-60-32	1/4" Hex Wrench	included
353-10-1	Tapping Compound	included
356-61	Tool Box	included

see pages TM-16 and TM-17 for complete list of components

TO ORDER:

1. Order B-Too Drilling Machine.
2. Order Drill/Taps per desired tap size, thread type and pipe type. Drill/Tap corresponds to body inlet threads on corporation stop.
3. Order Screw Plug Body (356-22-01) and Quick Release Screw Plugs with threads matching the body outlet threads of the corporation stops used. See chart to match screw plugs to bodies. (see page TM-17)
4. Order a pipe saddle for each size of pipe the B-Too will be used on. One extra chain section (Item Number 356-11) required for 18" - 30" mains, two extra chain sections required for 32" - 48" mains.
5. Order Power Unit if desired.
6. Order extra Tapping Compound if needed. (see pg. TM-30)

TRANSMATE

B-TOO™ DRILLING & TAPPING MACHINE



Transmate

a Division of Romac Industries, Inc.

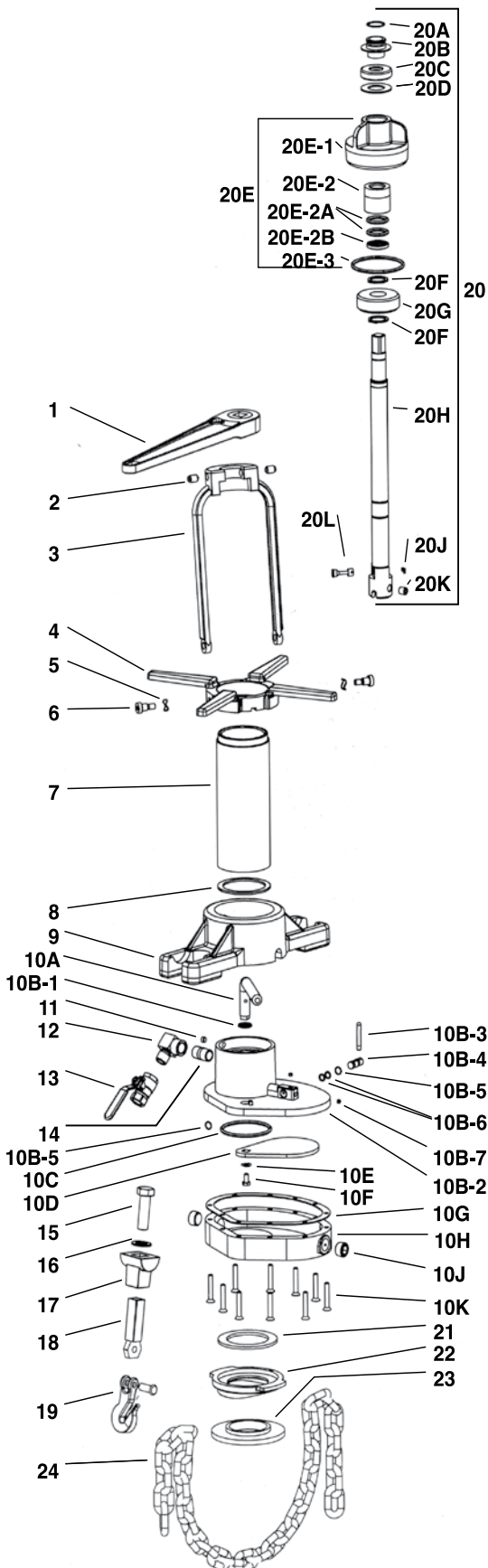

REF. NO.	ITEM NUMBER	DESCRIPTION	LIST PRICE
1	356-19	Ratchet Wrench (13/16")	\$300.22
2	356-06-02	Yoke Plunger, Vlier Std. (2 req'd)	ea.17.32
3	356-06	Yoke	172.74
4	356-07	Feed Nut	167.27
5	356-06-03	Yoke Bolt Washer (2 req'd)	ea. 5.53
6	356-06-01	Yoke Bolt, 1/2" x 1/2" socket (2 req'd)	ea. 5.45
7	356-05	Barrel	207.89
8	356-08-03	Gasket, Slide Gate to Barrel	16.78
9	356-12	Clamp	199.07
10	356-01A	Slide Gate Assembly	874.30
10A	356-02	Slide Gate Disk Handle	128.47
10B	356-03A	Slide Gate Top Assembly	510.60
10B-1	356-02-01	Slide Gate Handle O-ring	3.88
10B-2	356-03	Slide Gate Top	336.96
10B-3	356-20-10	By-Pass Valve: 1/4" Spool Lever	32.90
10B-4	356-20-1	By-Pass Valve: 1/4" Spool	72.61
10B-5	356-20-09	By-Pass Valve: 1/4" Spool Retaining Ring (2 req'd)	ea. 1.33
10B-6	356-20-08	By-Pass Valve: 1/4" Spool O-ring	1.33
10B-7	356-03-01	Slide Gate Top Plug 1/16" NPT Plug (2 req'd)	ea. 1.33
10C	356-04-01	Slide Gate Disk O-ring (2 req'd)	4.13
10D	356-04	Slide Gate Disk	118.36
10E	356-04-03	Disk Handle Washer	5.62
10F	356-04-04	Slide Gate Disk Screw	1.33
10G	356-08-02	Gasket Slide Gate	43.66
10H	356-01	Slide Gate Bottom	269.37
10J	356-01-02	Slide Gate Bottom Plug (2 req'd) 3/4" NPT	ea. 3.33
10K	356-03-05	Slide Gate Screw (10 req'd)	ea. 1.33
11	356-03-03	Slide Gate Top to Barrel Set Screw	1.33
12	356-03-04	Exhaust Elbow	18.29
13	371-02	Exhaust Valve	24.57
14	356-01-03	Slide Gate Pipe Nipple	2.32
15	356-14-02	Swivel Bolt for Rd. Link Chain (2 req'd)	ea. 6.37
16	8FW-Z12	Zinc Plated Washer 3/4" (2 req'd)	ea. 1.12
17	356-15	Hook Holder (2 req'd)	ea. 62.38
18	356-16	Hook Link (2 req'd)	ea. 80.22
19	356-11-01	Round Link Chain Hook (2 req'd)	ea. 25.13
20	356-10A	Holder Assembly	926.10
20A	356-21	Spiral Snap Ring	6.66
20B	356-17	Stop Collar	88.90
20C	355-56	Thrust Bearing	44.57
20D	356-18	Shaft Support Thrust Washer	62.38
20E	356-08A	Cap Assembly	244.14
20E-1	356-08	Cap only	177.09
20E-2	356-09A	Holder Bushing Assembly	77.76
20E-2a	356-09-01	Holder Bushing O-ring (2 req'd)	ea. 1.33
20E-2b	356-09-02	Holder Bushing Wiper	17.44
20E-3	356-08-01	Cap O-ring	1.99
20F	350-20-54	Shaft End Snap Ring (2 req'd)	ea. 12.72
20G	356-13	Holder Guide	28.63
20H	356-10	Holder	305.53
20J	353-11-506	Holder Cotter Pin	1.53
20K	353-11-514	Holder Socket Head Set Screw	2.32
20L	353-11-505	Holder Knockout Pin	53.57
21	356-08-04	Top Saddle Gasket	17.19
22	356-23-xx	B-Too Saddle xx Mueller Style (See following page)	
23	353-57-084	4" Bottom Saddle Gasket for 4" and larger	50.59
	353-57-083	3" Bottom Saddle Gasket, (Not Included)	22.34
	353-57-082	2" Bottom Saddle Gasket, (Not Included)	38.72
24	356-11	Chain, Round Link	71.68
Not Illustrated:			
	353-60-32	1/4" Hex Wrench	5.40
	353-10-1	Tapping Compound	33.90
	356-61	Tool Box	620.89

TRANSMATE



B-TOO™ DRILLING & TAPPING MACHINE PARTS LIST

ITEM NUMBER	DESCRIPTION	LIST PRICE
PVC Drills and Taps (requires both Cutter and Tap)		
355-01-210	Cutter, PCV 3/4": 5957 (AWWA CC thread)	\$311.50
353-04-206	Tap, 3/4" PVC: 5956 (AWWA CC thread)	436.39
353-01-206	Cutter, 1" PVC: 5975-1 (AWWA CC thread)	312.24
353-04-208	Tap, 1" PVC: 5956 (AWWA CC thread)	504.54
353-03	Drill Tap Roll Pin	1.96
DRILL/TAPS		
For Ductile, Cast Iron & A/C		
353-02-106	Drill/tap, 3/4" IP: 5951 (IP thread)	457.16
353-02-108	Drill/tap, 1" IP: 5951 (IP thread)	484.87
353-02-206	Drill/tap, 3/4" CC: 5950, 5952 (AWWA thread)	323.53
353-02-208	Drill/tap, 1" CC: 5950, 5952 (AWWA thread)	442.36
353-03	Drill Tap Roll Pin	1.96
SCREW PLUGS (other thread forms available upon request)		
356-22-01	B-Too, Quick Release Screw Plug Body 1"	213.88
356-22-02	B-Too, Quick Release Screw Plug 1" Coarse Thread Compression	169.34
356-22-03	B-Too, Quick Release Screw Plug 1" MIP	169.34
356-22-04	B-Too, Quick Release Screw Plug 1" Drive Thread	169.34
356-22-05	B-Too, Quick Release Screw Plug 1" FIP	169.34
356-22-06	B-Too, Quick Release Screw Plug 3/4" Coarse Thread Compression	169.34
356-22-07	B-Too, Quick Release Screw Plug 3/4" FIP	169.34
356-22-08	B-Too, Quick Release Screw Plug 3/4" MIP	169.34
356-22-09	B-Too, Quick Release Screw Plug 3/4" Drive Thread	169.34
356-22-10	B-Too, Quick Release Screw Plug Body 1-1/4" ¹	249.36
356-22-11	B-Too, Quick Release Screw Plug 1-1/4" Coarse Thread Compression ¹	196.07
356-22-12	B-Too, Quick Release Screw Plug 1-1/4" FIP ¹	196.07
356-22-13	B-Too, Quick Release Screw Plug 1" Fine Thread Compression	169.34
356-22-14	B-Too, Quick Release Screw Plug 3/4" Fine Thread Compression	169.34

¹ For use on 1" Corporations with 1-1/4" outlet threads.

ITEM NUMBER	DESCRIPTION	LIST PRICE
PIPE SADDLES		
356-23-02	*B-Too, Saddle 2" Mueller Style	\$62.38
356-23-03	*B-Too, Saddle 3" Mueller Style	62.38
356-23-04	B-Too, Saddle 4" Mueller Style	62.38
356-23-06	B-Too, Saddle 6" Mueller Style	62.38
356-23-08	B-Too, Saddle 8" Mueller Style	62.38
356-23-10	B-Too, Saddle 10" Mueller Style	62.38
356-23-12	B-Too, Saddle 12" Mueller Style	62.38
356-23-14	B-Too, Saddle 14" Mueller Style	62.38
356-23-16	B-Too, Saddle 16" Mueller Style	62.38
356-23-18	B-Too, Saddle 18" Mueller Style	62.38
356-23-20	B-Too, Saddle 20" Mueller Style	62.38
356-23-24	B-Too, Saddle 24" Mueller Style	62.38

* must order bottom saddle gasket, see TM-16
30" - 60" SADDLES ALSO AVAILABLE

TAPPING COMPOUND		
353-10-1	Tapping Compound	33.90
353-10-3	Tapping Compound / Case (12)	390.95

POWER OPTION		
373-356	Ridgid 690 Electric Drive w/ 13/16" sq. drive adapter	3,075.52
370-70	GF-15 Ground Fault Interrupter Plug (required)	131.61

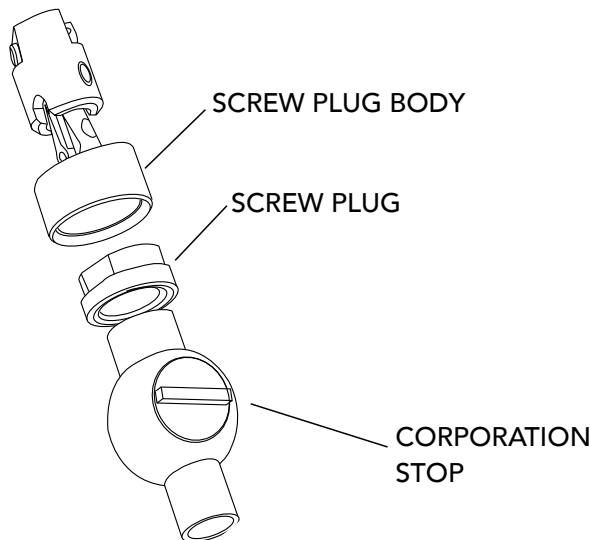

SCREW PLUG CHART		
BODY SIZE	SCREW PLUGS THAT FIT	
1" Body	1" Compression (356-22-01) 1" MIP 1" Drive Thread 1" Mueller Thread	3/4" Compression 1" FIP 3/4" FIP 3/4" MIP 3/4" Drive Thread 3/4" Mueller Thread
1-1/4" Body	1-1/4" Compression	1-1/4" FIP

CUTTING DRILL/TAPS

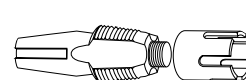

355-01-210 PVC CUTTER 3/4" CC
 353-04-206 PVC TAP 3/4" CC

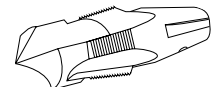

353-01-206 PVC CUTTER 1" CC
 353-04-208 PVC TAP 1" CC