



INSTALLATION, OPERATION & MAINTENANCE INSTRUCTIONS

1455 Kleppe Lane ♦ Sparks, NV 89431-6467 ♦ (775) 359-4712 ♦ Fax (775) 359-7424
HAWS AG ♦ Bachweg 3 ♦ CH-3401 Burgdorf ♦ Switzerland
Haws Mfg. Pte Lt. ♦ 2A Sungei Kadet Drive ♦ Singapore 729554
Avlis-Avenida Senador, Testonio Vilela ♦ 505 Jardim Aeroporto ♦ Itu, S.P. 13304-550 ♦ Brasil
E-mail: haws@hawsco.com ♦ website: www.hawsco.com

No. 2080227(3)

Model 9102 Stainless Steel Dust Cover

NOTE TO INSTALLER: Please leave this information with the Maintenance Department.

LIMITED WARRANTY

HAWS® warrants that all of its products are guaranteed against defective material or poor workmanship for a period of **one year from date of shipment**. HAWS liability under this warranty shall be discharged by furnishing without charge F.O.B. HAWS Factory any goods, or part thereof, which shall appear to the Company upon inspection to be of defective material or not of first class workmanship, provided that claim is made in writing to company within a reasonable period after receipt of the product. Where claims for defects are made, the defective part or parts shall be delivered to the Company, prepaid, for inspection. HAWS will not be liable for the cost of repairs, alterations or replacements, or for any expense connected therewith made by the owner or his agents, except upon written authority from HAWS, Sparks, Nevada. HAWS will not be liable for any damages caused by defective materials or poor workmanship, except for replacements, as provided above. Buyer agrees that Haws has made no other warranties either expressed or implied in addition to those above stated, except that of title with respect to any of the products or equipment sold hereunder and that HAWS shall not be liable for general, special, or consequential damages claimed to arise under the contract of sale.

The emergency equipment manufactured by HAWS is warranted to function if installation and maintenance instructions provided are adhered to. The units also must be used for the purpose, which they were intended. This product is intended to supplement first-aid treatment. Due to widely varying conditions HAWS cannot guarantee that the use of this emergency equipment will prevent serious injury or the aggravation of existing or prior injuries.

NO OTHER WARRANTIES EXPRESSED OR IMPLIED ARE AUTHORIZED, PROVIDED OR GIVEN BY HAWS.

SHOULD YOU EXPERIENCE DIFFICULTY WITH THE INSTALLATION OF THIS MODEL, PLEASE CALL:

1-800-766-5612

FOR PARTS CALL:

1-800-758-9378

**(U.S.A. AND CANADA ONLY) MONDAY-THURSDAY: 6:00 A.M. – 4:00 P.M. PST
FRIDAY: 6:00 A.M – 1:00 P.M. PST**

INSTALLATION PROCEDURE

Refer to the attached drawing to clarify installation.

- STEP 1:** Remove the nut that holds the eyewash push flag to the valve stem. If the unit is also foot operated, remove the ring from the end hole of the flag.
- STEP 2:** Position the dust cover assembly over the existing $\varnothing 11$ " eyewash receptor. After checking for the initial alignment, tighten the adjustable strap around the receptor only enough to keep it from sliding during the installation process.
- STEP 3:** Put the flag on the valve stem before attaching the link on it through the first hole on the link. Secure the flag and the link to the valve stem by tightening the shoulder nut provided.
- STEP 4:** Align the second holes on the flag and the link. Insert the $3/8$ " – 24 UNC x 1" screw (with hole) through the holes and tighten it with the nut. Use some lubricant if necessary.
- STEP 5:** If the eyewash is foot operated, reattach the ring connected to the chain into the hole of the $3/8$ " – 24 UNC x 1" screw.
- STEP 6:** After making sure that the cover and the receptor are properly positioned, tighten the adjustable strap firmly to secure the dust cover assembly on the eyewash unit.
- STEP 7:** Test the eyewash to ensure the full access and the sufficient water flow while open.

TROUBLESHOOTING

Before performing any troubleshooting work, inform all related parties of the discontinuation of service. Service to be performed on equipment by qualified personnel.

PROBLEM	REPAIR CHECKLIST
1. Cover does not open all the way.	1. a. Check for obstructions behind the unit. b. If the unit is also foot operated, check the chain length and adjust it if necessary.
2. Cover is not aligned with the receptor.	2. a. Loosen the strap then adjust the link and the back mounting bracket.

NOTES:

1. EYEWASH RECEPTOR, STRAINER, BALL VALVE, MOUNTING BRACKET, AND PUSH FLAG ARE NOT SUPPLIED AND SHOWN FOR REFERENCE ONLY.

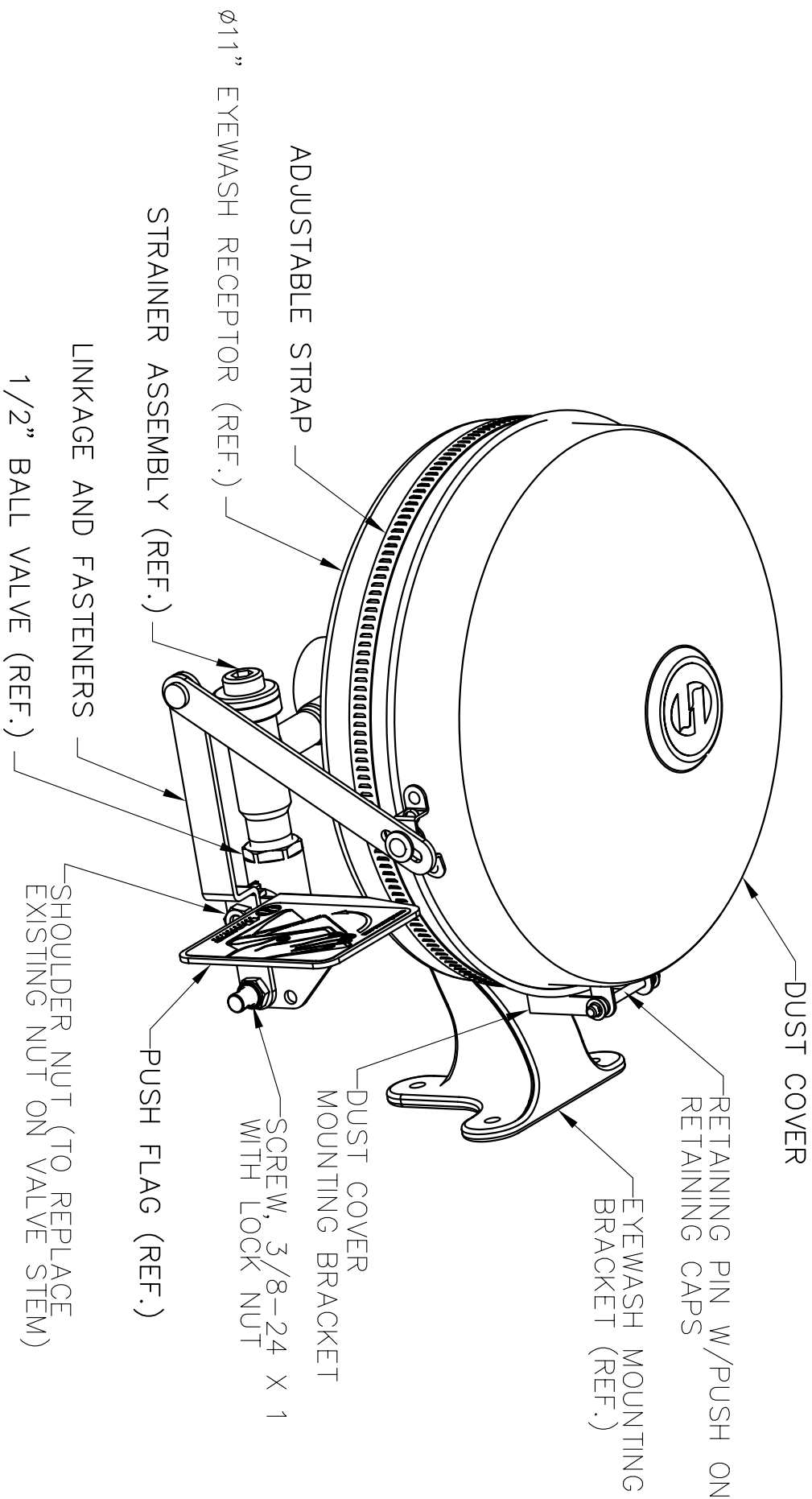

INFO FAX : 1-888-FAX-HAWS (1-888-329-4297)
 1455 Kleppe Ln, Sparks NV, 89431
 Phone: 775-359-4712 Fax: 775-359-7424
 Haws Ag Bochweg 3 CH-3401 Burgdorf Switzerland
 Haws Mfg Pte Ltd 74 Sungai Kadut Loop Singapore 729531
 e-mail: Haws@hawsco.com website: www.hawsco.com

FORM NO.	REVISED PER DATE	MODEL(S)	PART NUMBER
9102	3900 HM 05/19/02	9102 STAINLESS STEEL DUST COVER	0002080227.D
ISSUE NO.	DATE	INFO FAX DOC #	DRAWING NUMBER
0001	05/19/02	29102	0002080227.D
SCALE	1:1	DRAWING TYPE	SIZE A 1 of 1