

# INSTALLATION INSTRUCTIONS

Read installation instructions first before installing. Check parts to ensure that no damage has occurred during transit and that no parts are missing. Also check the diameter of the pipe and the range marked on the clamp to ensure you have the proper size.

## Style 516 Bell Joint Leak Clamp 10", 12" & 14" Sizes

**Step 1** • Check the BJLC parts to insure that no damage has occurred during transit. Clean all around the pipe and on the face of the bell where the gasket will contact. These surfaces must be free of all lead, dirt, etc.

**Step 2** • Lubricate the gasket with a suitable gasket lubricant. Wrap the gasket around the pipe with the thick edge of the gasket toward the bell. The gasket ends should meet so that the puzzle joint interlocks. If necessary, remove gasket section as indicated below:

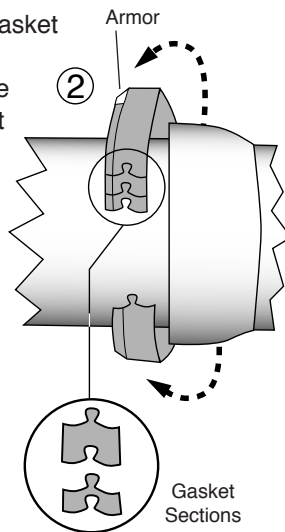

Nom. Size	Pipe O.D.	Gasket
10"	11.10	Remove single section
	11.40	Remove no section
12"	13.20	Remove both sections
	13.50	Remove small section
	13.65	Remove no section
14"	15.30	Remove single section
	15.65	Remove no section

**Step 3** • Align the two armors in the gasket to bridge the gaps at the ends of the casting halves.

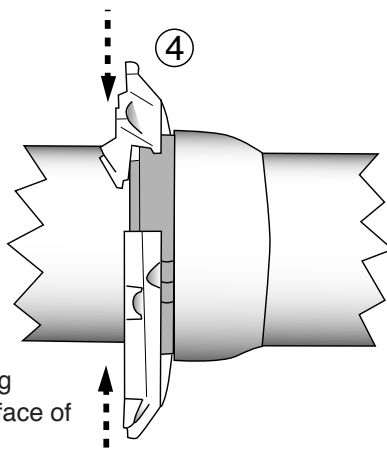

**Step 4** • Assemble the pipe half (indicated by "PH" on casting) around the pipe (it may be necessary to insert one bolt with nuts to hold ring segments together). Push the assembled ring and gasket against the face of the bell.

**Step 5** • Assemble the bell half (indicated by "BH" on casting) around the pipe behind the bell. Insert bolts and hand tighten all nuts.

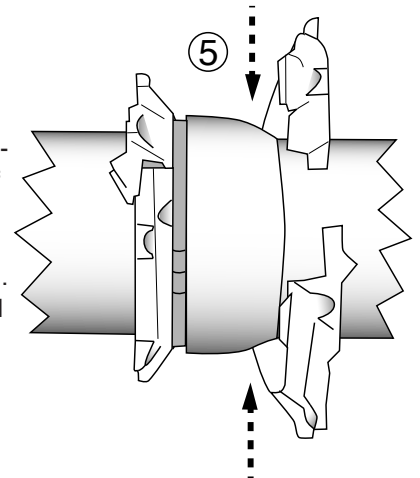

**Step 6** • Tighten bolts in the following order:

- Tighten adjusting bolts to 35 ft-lbs.
- Tighten the four bolts closest to the adjusting bolt to 75 ft-lbs.
- Tighten the outer four bolts to 75 ft-lbs after the inner bolts are fully tightened.

**Note:**  
35 ft-lbs. torque = 12" wrench w/35 lbs. force  
75 ft-lbs. torque = 12" wrench w/75 lbs. force

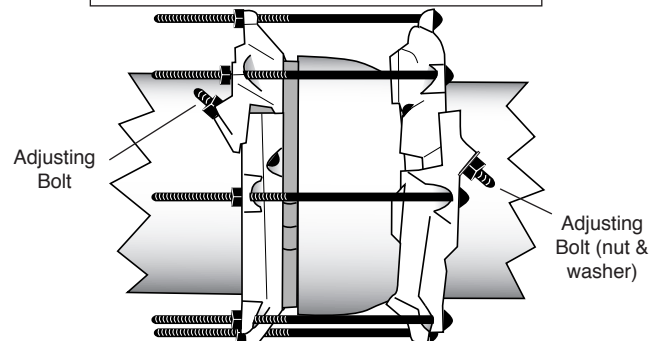

**Step 7** • Check for leaking. Re-tighten the bolts evenly around the pipe as necessary to stop leaking.

## Bell Joint Leak Clamp

# Style 516

### 10", 12" & 14" Sizes

### PRECAUTIONS

1. Check diameter of pipe to make sure you are using the correct size clamp; also check gasket to make sure it is the size you think it is.
2. Clean pipe to remove as much dirt and corrosion as possible from pipe surface and bell face where the gasket will contact. Lubrication gasket and pipe with soapy water or approved pipe lubricant per ANSI/AWWA C111/A21.11.
3. Make sure no foreign materials lodge between gasket and pipe.
4. Avoid loose fitting wrenches, or wrenches too short to achieve proper torque.
5. Keep threads free of foreign material to allow proper tightening.
6. Take extra care to follow proper bolt tightening procedures and torque recommendations. Bolts are often not tightened enough when a torque wrench is not used.
7. Be sure the armors in the gasket bridge the gaps at the casting joints
8. The thick edge of the gasket should be facing the bell face.
9. Pressure test for leaks before backfilling.
10. Backfill and compact carefully around pipe and fitting.
11. When reinstalling parts with stainless steel hardware there may be a loss in pressure holding ability due to worn or damaged threads during the original installation.

### COMMON INSTALLATION PROBLEMS

1. Bolts are not tightened to the proper torque.
2. Rocks or debris between pipe and gasket.
3. Dirt on threads of bolts or nuts.
4. Puzzle joint in gasket not off set from casting joint.
5. Thick end of gasket not toward the bell face.
6. Too much pipe deflection.