

The original, and the definitive standard.

# RESILIENT WEDGE GATE VALVES

2" THROUGH 12"  
STYLE 4067



AWWA C509 250 PSI • UL/FM Approved 200 PSI • NSF 61 Certified •  
Full Water Way • Fusion Bond Epoxy Coated • 10 Year Limited Warranty



**M&H VALVE COMPANY**

*M&H Valve is a division of McWane, Inc.*

[www.mh-valve.com](http://www.mh-valve.com)



For Generations

# RESILIENT WEDGE VALVE

In 1975, M&H recognized the increased requirements and escalating maintenance cost of water systems in the United States.

M&H responded by introducing the first R/W (Resilient Wedge) Valve in America. This introduction revolutionized the valve market in the U.S.

M&H was the first to introduce, and still leads in the design and technical development, of the bubble-tight resilient seating valve.

The M&H Resilient Wedge Valve, with its unique features and benefits, were the first to be manufactured with both AWWA and UL/FM approval for all water system requirements.

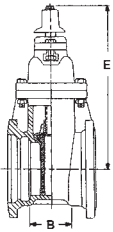

**4067  
MECHANICAL JOINT  
2" - 12"**

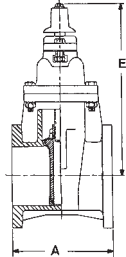

**4067-02  
FLANGED  
2" - 12"**

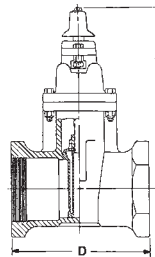

**4067-07  
THREADED ENDS  
2" - 3"**

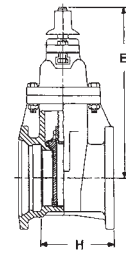

**4067-13  
FLANGED X MJ  
3" - 12"**

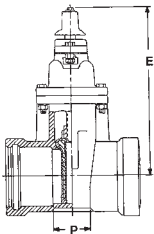

**4067-03  
PUSH ON FOR  
SDR PVC  
2" - 12"**

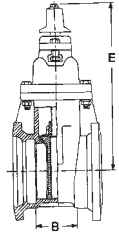

**4576-01  
PUSH ON FOR  
CUTTING IN JOINT  
4" - 12"**

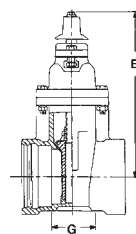

**4067-22  
TYTON ENDS FOR DUCTILE  
IRON AND C900 PVC PIPE  
4" - 12"**

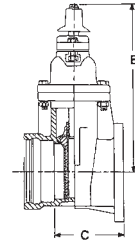

**4067-23  
FLANGED X TYTON  
4" - 12"**

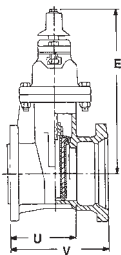

**4751-01  
MECHANICAL JOINT  
FOR TAPPING  
3" - 12"**

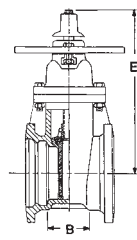

**4067-01P  
MECHANICAL JOINT  
POST INDICATOR VALVE  
2" - 12"**

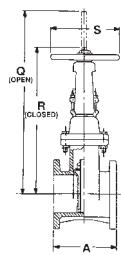

**4068-02  
FLANGED OS & Y  
CONSTRUCTION  
2" - 12"**

**NOTE:**

It is recommended that valves be installed with stems vertical when used in raw sewage or sludge applications or in water with excessive sediment. Flanged end connections not recommended for buried service.

VALVE SIZE	A	B	C	D	E	G	H	P	Q	R	S	U	V	NO. OF TURNS TO FULL OPEN
2"	7	3-1/4	-	5-3/8	10-7/8	-	-	3	10	12	7-1/4	-	-	6-1/2
2-1/2"	7-1/2	-	-	7-1/8	11-3/8	-	-	3-1/4	16-3/8	13-7/8	7-1/4	-	-	8
3"	8	3-1/2	-	7-1/8	12-3/8	-	5-3/4	3-1/2	18-7/8	15-5/8	10	5-3/4	8-1/4	10
4"	9	4-1/2	6-3/4	-	14-3/4	4-5/8	6-3/4	4-1/2	22-3/4	18-1/4	10	6-3/4	9-1/4	13-1/2
6"	10-1/2	5-1/2	7-7/8	-	19	5-1/4	8	5	30-1/8	23-3/4	12	8	10-1/2	19-1/2
8"	11-1/2	8-1/8	8-1/2	-	22-1/2	5-5/8	9-3/4	5-1/2	37-3/4	29-1/4	14	10-3/4	13-1/4	25-1/2
10"	13	10-1/2	10	-	26-1/2	7	11-3/4	7	45-3/4	35-3/8	18	12-1/2	14-7/8	31-1/2
12"	14	10-3/4	11-1/4	-	30	8-1/2	12	8-1/2	53-1/8	40-5/8	18	12-1/2	15	37-3/4

# ENGINEERING FEATURES

## THRUST BEARINGS

Delrin thrust bearings above and below the thrust collar reduce friction and minimize operating torques.

## COPPER ALLOY STEM

Long, trouble-free life with high strength, non-corrosive copper alloy stem and stem nut.

## STAINLESS STEEL HARDWARE

304 stainless steel nuts and bolts provide long-life corrosion protection.

## 100% COATED WEDGE

100% coated wedge ensures bubble-tight seal every time up to 250 PSI. With twin seal design.

## ELLIPTICAL BOLT HOLES

Hole design on MJ connection eliminates the need for anti-rotation bolts.

## MINIMAL FLOW LOSS

Smooth, unobstructed waterway is free of pockets, cavities and depressions, allowing for minimal flow loss and lower pumping costs. All valves accept full-size tapping cutter.

## REPLACEABLE O-RINGS

Two O-ring seals are replaceable with the valve fully open and subjected to full-rated working pressure.

## NO FLAT GASKETS

O-ring seals at stuffing box and bonnet to body flanges to ensure the best possible seal. No flat gaskets.

## EPOXY COATING

M&H corrosion resistant fusion-bonded epoxy coating, conforming to AWWA C550 and NSF 61 Certified, protects both inside and outside of valve.

## EASY STORAGE

Pads on the bottom of all valves keep valve in upright position for easier storage and protection from the elements.

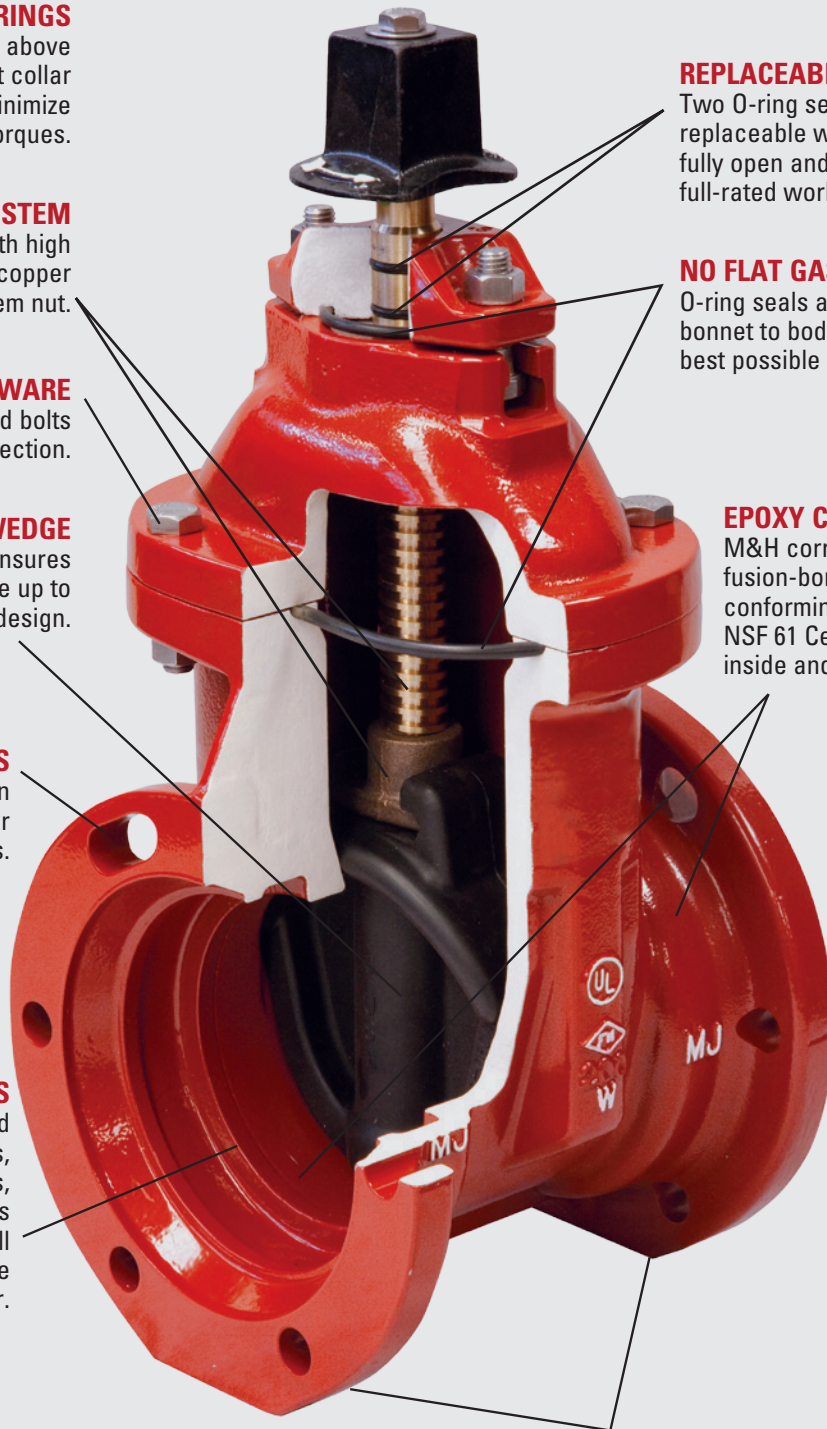

**VALVE RATING:** All valves are rated at 250 PSI for AWWA service and 200 PSI for UL/FM service. All valves are hydrostatically tested to 500 PSI.



## COMMITTED TO ENVIRONMENTAL RESPONSIBILITY

M&H VALVE COMPANY IS COMMITTED TO PROTECTING OUR NATURAL RESOURCES THROUGH ENVIRONMENTALLY RESPONSIBLE MANUFACTURING PRACTICES, INCLUDING THE USE OF 80+% RECYCLED CONTENT IN OUR HYDRANTS AND VALVES.

To learn more about our commitment to the environment, call 256-237-3521

## RECOMMENDED SPECIFICATIONS

1. Valves shall conform to the latest revision of AWWA Standard C509 covering resilient seated gate valves for water supply service.
2. The valves shall have an iron body, bonnet, and O-ring plate. The wedge shall be totally encapsulated with rubber.
3. The sealing rubber shall be permanently bonded to the wedge per ASTM D429.
4. Valves shall be supplied with O-ring seals at all pressure retaining joints. No flat gaskets shall be allowed.
5. The valves shall be either non-rising stem or rising stem, opening by turning left or right, and provided with 2" square operating nut or a handwheel with the word "Open" and an arrow to indicate the direction to open.
6. Stems shall be cast copper alloy with integral collars in full compliance with AWWA. All stems shall operate with copper alloy stem nuts independent of wedge and of stem (in NRS valves).
7. All stems shall have two O-rings located above thrust collar and one O-ring below. Stem O-rings shall be replaceable with valve fully opened and subjected to full pressure. The stems on 2" – 12" shall also have a low torque thrust bearing located above and below the stem collar to reduce friction during operation.
8. Waterway shall be smooth, unobstructed and free of all pockets, cavities and depressions in the seat area. Valves 2" and larger shall accept a full size tapping cutter.
9. The body, bonnet and O-ring plate shall be fusion-bonded epoxy coated, both interior and exterior on body and bonnet. Epoxy shall be applied in accordance with AWWA C550 and be NSF 61 Certified.
10. Each valve shall have maker's name, pressure rating, and year in which it was manufactured cast in the body. Prior to shipment from the factory, each valve shall be tested by hydrostatic pressure equal to the requirements of AWWA C509 (and UL/FM where applicable).
11. Valves shall have all component parts cast and assembled in the USA and shall be manufactured by the M&H Valve Company.



[www.mh-valve.com](http://www.mh-valve.com)



M&H VALVE COMPANY

605 West 23rd Street • Anniston, Alabama 36201  
PHONE 256-237-3521 FAX 888-549-5309



For Generations

SPECIFICATIONS / AVAILABLE CONFIGURATIONS & STYLE NUMBERS (2"- 12")  
**M&H AWWA C509 RESILIENT WEDGE GATE VALVES (1993)**

**M&H Valve AWWA C509 Resilient Wedge Gate Valves**  
**Meet or Exceed the Requirements of AWWA Standard C509**

Size Range	Water Working Pressure psi	Bubble Tight Seat Test psi	Hydrostatic Shell Test psi
AWWA 2" – 12"	250 Water Works	250 & 400	500
ULFM 4" – 12"	200 Fire Protection	250 & 400	500

<u>Available End Connections</u>	<u>Size Range</u>	<u>Style No. With 2" Nut</u>	<u>Style No. With Hand wheel</u>	<u>Style No. With Post Plate</u>
Mechanical Joint (NRS) (no 2 1/2")	2"-12"	4067-01	4067-01-HW	4067-01P (3"-12")
Flanged Ends (NRS)	2"-12"	4067-02	4067-02-HW	4067-02P (3"-12")
Flanged End X Mechanical Joint (NRS)	3"-12"	4067-13	4067-13-HW	4067-13P (3"-12")
Push-on (For PVC / SDR) (NRS)	2"-12"	4067-03	4067-03-HW	4067-03P (3"-12")
Threaded (NRS)	2"-3"	4067-07	4067-07-HW	4067-07P (3" only)
Threaded (NRS)(With T-Head Nut)	2"-3"	4067-07THN (With T-Head Nut)		
***Threaded (OS&Y)	2"-3"	N/A	4068-07	
Tyton X Tyton (NRS) (For D.I. / C900)	4"-12"	4067-22	4067-22-HW	4067-22P (4"-12")
Tyton X Flange (NRS) (For D.I. / C900)	4"-12"	4067-23	4067-23-HW	4067-23P (4"-12")
***Flanged Ends (OS&Y)	2"-12"	N/A	4068 & 4068A*	N/A
**Tapping Valve (NRS)	4"-12"	4751-01	4751-01HW	4751-01P (4"-12")
M.J. Cutting-in valve (NRS)	4"-12"	4576-01	4576-01-HW	4576-01P (4"-12")
****Flanged End (Open Mitre Box)	3"-12"	4211-O	4211-O-HW	N/A
****Flanged End (Enclosed Mitre Box)	4"-12"	4211-C	4211-C-HW	N/A

Notes: \*4068A is Tapped & Plugged in "A" Position (2" – 4" = 1/2" tap)(6" – 12" = 3/4" tap)  
 \*\*Each size accommodates a full size diameter tapping cutter.  
 \*\*\*2" OS&Y Flanged and Threaded versions are UL Listed.  
 \*\*\*\*Can provide with all available end connections.  
 2" and 2 1/2" are not included in AWWA C509.

NOTE: It is recommended that valves be installed with stems vertical when used in raw sewage or sludge applications or in water with excessive sediment.



**RECOMMEND SPECIFICATIONS (NRS STYLE 4067)(OS&Y STYLE 4068)(2"-12")  
M&H AWWA C509 RESILIENT WEDGE GATE VALVES (1993)**

**RECOMMENDED SPECIFICATIONS (2"-12")**

1. Valves shall conform to the latest revision of AWWA Standard C509 covering resilient seated gate valves for water supply service.
2. The valves shall have an iron body, bonnet, and O-ring plate. The wedge shall be totally encapsulated with rubber.
3. The sealing rubber shall be permanently bonded to the wedge per ASTM D-429.
4. Valves shall be supplied with O-ring seals at all pressure retaining joints. No flat gaskets shall be allowed.
5. The valves shall be either non-rising stem or rising stem, opening by turning left or right, and provided with 2" square operating nut or a handwheel with the word "Open" and an arrow to indicate the direction to open.
6. Stems shall be cast copper alloy with integral collars in full compliance with AWWA. All stems shall operate with copper alloy stem nuts independent of wedge and of stem (in NRS valves). OS&Y (rising stems) shall be bronze
7. All stems shall have two O-rings located above the thrust collar and one O-ring below. Stem O-rings shall be replaceable with valve fully opened and subjected to full pressure.
8. The stems on 2"-12" shall also have a low torque thrust bearing located above and below the stem collar to reduce friction during operation.
9. Waterway shall be smooth, unobstructed and free of all pockets, cavities and depressions in the seat area. Valves 2" and larger shall accept a full size tapping cutter.
10. The body, bonnet and O-ring plate shall be fusion-bonded epoxy coated, both interior and exterior on body and bonnet. Epoxy shall be applied in accordance with AWWA C550 and be NSF 61 Certified.
11. Each valve shall have maker's name, pressure rating, and year in which it was manufactured cast in the body. Country of origin to be clearly cast into body & cover castings.
12. Prior to shipment from the factory, each valve shall be tested by hydrostatic pressure equal to the requirements of AWWA C509 (and UL/FM where applicable).
13. Valves shall have all component parts cast and assembled in the USA and shall be manufactured by the M&H Valve Company.

NOTE: It is recommended that valves be installed with stems vertical when used in raw sewage or sludge applications or in water with excessive sediment.

**September 1, 2012 / C509 Gate Valves**

PRODUCT ANALYSIS (2"-12")

**M&H AWWA C509 RESILIENT WEDGE GATE VALVES (1993)**

<b>FEATURES</b>	<b>BENEFIT</b>
2"-12" Bubble Tight Closure at 250 psi (AWWA Service)	<ul style="list-style-type: none"> <li>• No Leakage – No loss of water</li> </ul>
Wedge Has Dual Rubber Seal	<ul style="list-style-type: none"> <li>• Assures drop-tight shut-off in either direction.</li> </ul>
Smooth, Unobstructed Waterway to Maximize Flow.	<ul style="list-style-type: none"> <li>• High flow characteristics</li> <li>• 100% smooth passage without turbulent flow</li> <li>• No sediment build up</li> <li>• Will not impede travel of line cleaning tools</li> </ul>
Only Three Internal Parts	<ul style="list-style-type: none"> <li>• Virtually maintenance free</li> </ul>
Integral Cast Tongue and Groove Between Wedge and Valve Body.	<ul style="list-style-type: none"> <li>• Positive gate alignment every time</li> </ul>
No Metal Seat Rings	<ul style="list-style-type: none"> <li>• Nothing to be damaged by scoring</li> </ul>
Delrin* Anti-Friction Thrust Bearing	<ul style="list-style-type: none"> <li>• Operating torque to close and open held to absolute minimum</li> </ul>
Solid, Bronze Stem Nut and High Strength Bronze Stem	<ul style="list-style-type: none"> <li>• No corrosion</li> <li>• Trouble free service</li> </ul>
Stem Nut is Self Centering	<ul style="list-style-type: none"> <li>• Eliminates possible stress on stem and wedge</li> </ul>
Two O-Ring Seals Above Stem Thrust Collar and One Below	<ul style="list-style-type: none"> <li>• Two O-Rings can be replaced with valve in service (Valve needs to be fully opened)</li> </ul>
High Strength Iron Wedge Fully Encapsulated with Rubber Permanently Bonded to Metal.	<ul style="list-style-type: none"> <li>• Trouble free service with minimum maintenance</li> <li>• No leaks – no wear</li> </ul>
No Lubrication Required	<ul style="list-style-type: none"> <li>• Trouble free service</li> </ul>
Body / Bonnet Epoxy Coating Inside & Out	<ul style="list-style-type: none"> <li>• Unprecedented Protection Against Corrosion and abrasion</li> </ul>
10 Year Limited Warranty Against Defective Materials or Workmanship	<ul style="list-style-type: none"> <li>• Customer assurance that M&amp;H believes in the strong product they produce.</li> </ul>
American Cast and Assembled	<ul style="list-style-type: none"> <li>• American Jobs</li> <li>• American backed for more than 100 years</li> <li>• American quality and accountability</li> </ul>

\* DuPont Trademark

NOTE: It is recommended that valves be installed with stems vertical when used in raw sewage or sludge applications or in water with excessive sediment.

PERFORMANCE INFORMATION (AWWA & UL/FM)

**M&H AWWA C509 RESILIENT WEDGE GATE VALVES (1993)**

**2"-12" AWWA PERFORMANCE INFORMATION**

1. Valve complies with AWWA C509 specs where applicable.
2. Valve is rated at 250psi working pressure.
3. Valve is bubble-tight at all pressures up to full rated pressure (250psi).
4. Valve has been subjected to torques 150 percent of the designated minimum required torques.
5. Valve has been cycle tested full opened to close 5,000 times without loss of bubble-tight seal.
6. Rubber to iron bond on wedge is inspected for strength as per ASTM D 429 specification.

**4"-12" UL/FM PERFORMANCE INFORMATION**

1. Valve complies with Underwriters Laboratory standard UL 262.
2. Valve is UL/FM rated at 200psi working pressure.
3. Valve is bubble-tight at all pressures up to the full rated pressure (200psi)
4. Valve is capable of bubble-tight seal at twice the rated pressure (400psi) for short periods of time.
5. 4"-6" valve sizes have been hydrostatically shell tested at five times the rated pressure (1,000 psi).
6. 8", 10", and 12" valve sizes have been hydrostatically shell tested at four times the rated pressure (800psi).
7. Valves has been subjected to torques 150 percent of the designated minimum required torques.
8. Valve has been cycle tested 5,000 times without loss of bubble-tight seal.
9. Rubber to iron bond on wedge is inspected for strength as per ASTM D 429 specification.

Note: For complete data on the tests Underwriters Laboratories performed reference UL File EX783

NOTE: It is recommended that valves be installed with stems vertical when used in raw sewage or sludge applications or in water with excessive sediment.



MATERIAL SPECIFICATIONS (1 of 2)

**M&H AWWA C509 RESILIENT WEDGE GATE VALVES (1993)**

**CAST IRON SPECIFICATION ASTM A126 CLASS B**

Physical Properties

Minimum tensile strength	31,000 psi
Minimum transverse strength	3,300 lbs.
Minimum deflection (12" Centers)	.12 in

Chemical Analysis (percent)

Phosphorus (maximum)	.75
Sulfur (maximum)	.15

**DUCTILE IRON SPECIFICATION ASTM A536**

Physical Properties

Minimum tensile strength	65,000 psi
Minimum yield strength	45,000 psi

**STYRENE BUTADINE RUBBER – ASTM D-5000 “O-Rings” & “Wedge / Seat Rubber”**

Hardness	78± 5
100% Modulus (PSI)	800

**ALTERNATE---EPDM “O-Rings” & “Wedge / Seat Rubber”**

Hardness	80± 2
100% Modulus (PSI)	600
Tensile (PSI)	1,450
Elongation (%)	150
Compression set, ASTM D395 Method B	18% max.

## MATERIAL SPECIFICATIONS (2 of 2)

# M&H AWWA C509 RESILIENT WEDGE GATE VALVES (1993)

### STANDARD CAST BRONZE—ASTM B584 CDA836 (Stem Nut)

#### Physical Properties

Minimum tensile strength	30,000psi
Minimum yield strength	14,000psi
Minimum elongation (in 2 inches)	20%

#### Chemical Analysis

*Copper	84.0 – 86.0
Lead	4.0 – 6.0
Tin	4.0 – 6.0
Nickel (maximum)	1.0
Zinc	4.0 – 6.0

\* = CU + NI = 79% Min

### CAST BRONZE – ASTM B584 CDA867 (Stem)

**In accordance with SECTION 4.4.5 of AWWA C509**

#### Physical Properties

Minimum tensile strength	80,000 psi
Minimum yield strength	32,000 psi
Minimum elongation (in 2 inches)	15%

#### Chemical Analysis

Copper	55.0 – 60.0
Lead (maximum)	.50 – 1.5
Aluminum	1.0 – 3.0
Iron	1.0 – 3.0
Nickel (maximum)	1.0
Zinc	30.0 – 38.0
Manganese	1.0 – 3.5
Tin (maximum)	.2

### ALTERNATE CAST BRONZE – NDZ-S ASTM B763 UNS C99500 (Stem )

**In accordance with SECTION 4.4.5 of AWWA C509**

#### Physical Properties

Minimum tensile strength	70,000 psi
Minimum yield strength	40,000 psi
Minimum elongation (in 2 inches)	12%

#### Chemical Analysis

Copper	82.8
Lead (maximum)	.25
Aluminum (maximum)	2.0
Iron (maximum)	5.5
Nickel (maximum)	5.5
Zinc (maximum)	2.0
Silicon (maximum)	2.0

FLOW COEFFICIENTS (2"-12")

**M&H AWWA C509 RESILIENT WEDGE GATE VALVES (1993)**

**FLOW COEFFICIENTS (2"-12")**

VALVE SIZE	Cv (FULL OPEN)	K (FULL OPEN)
2"	300	0.15
2 1/2"	500	0.130
3"	800	0.115
4"	1500	0.105
6"	3600	0.090
8"	6700	0.080
10"	10,500	0.080
12"	15,000	0.080

Note: 2" & 2 1/2" not included in AWWA C509

$$C_v = \frac{Q}{\sqrt{\Delta P}} \qquad K = f \frac{L}{D}$$

Values given are calculated, based on hydraulic lab test on 6" R/W valve.

CR (CORROSION RESISTANCE ) INTERIOR & EXTERIOR COATING (1 of 2)  
**M&H AWWA C509 RESILIENT WEDGE GATE VALVES (1993)**

**CR (CORROSION RESISTANCE) COATING**

M&H Valves CR Coating is a high performance, one-part, heat-curable, thermoset coating which provides superior corrosion resistance protection for metal parts.

M&H Valves CR Coating material is a stable, non-toxic resin consisting of 100% solids. It is impervious to and imparts no taste to potable water. M&H CR Coating is formulated from materials deemed acceptable in the Food and Drug Administration's Document Title 21 of the Federal Regulations on food additives, Section 175.300 entitled "Resinous and Polymeric Coatings".

M&H Valves CR Coating is applied by a heat application, fusion—bonding process which secures the coating materials to the metal valve components. This process provides a continuous coating 6-8 mils thick with excellent adhesion qualities.

The durable M&H Valve CR Coating has a hard finish and exhibits excellent corrosion resistance in the most aqueous solutions and good abrasion resistance. It will not sag or cold flow or become soft during long-term storage. In addition to excellent corrosion resistance to aqueous solutions, the coating has excellent stability and resistance to acidic soil conditions.

M&H Valve CR Coating meets the requirements of the American Water Works Association Standard C-550 entitled "Protective Interior Coatings for Valves and Hydrants". This high performance coating has a ten year history of satisfactory service as a corrosion protection coating used in corrosive potable water applications and soil conditions.

**CR (CORROSION RESISTANCE ) INTERIOR & EXTERIOR COATING (2 of 2)**  
**M&H AWWA C509 RESILIENT WEDGE GATE VALVES (1993)**

**CR (CORROSION RESISTANCE) COATING**

CHEMICAL	Epoxy Rating	
	70°F	180° F
<b>ACIDS:</b>		
Acetic, 10%	F	N
Benzene Sulfonic, 10%	E	E
Benzoic	E	E
Boric	E	E
Chloracetic, 10%	E	E
Chromic, 5%	F	N
Citric, 10%	E	N
Fatty Acids	E	E
Fronmic, 90%	E	F
Hydrobromic, 20%	G	G
Hydrochloric, 20%	E	G
Hydrocyanic	E	E
Hydrofluoric, 20%	G	G
Hypochlorous, 5%	F	N
Lactic, 5%	F	N
Maleic, 25%	E	E
Nitric, 5%	E	G
Nitric, 30%	G	P
Oleic	E	E
Oxalic	E	E
Phosphoric	G	F
Picric	G	F
Steraric	E	E
Sulfuric, 50%	G	F
Tannic	E	E
Ketones	F	F
Ethers	F	F
Esters	F	F
Gasoline	E	E
Cargon Tetrachloride	E	E
<b>ORGANICS:</b>		
Aniline	G	P

CHEMICAL	Epoxy Rating	
	70°F	180° F
<b>ALKALIES:</b>		
Ammonium Hydroxide	E	E
Calcium Hydroxide	E	E
Potassium Hydroxide	E	E
Sodium Hydroxide	E	E
<b>ACID SALTS:</b>		
Aluminum Sulfate	E	E
Ammonium Chloride*	E	E
Copper Chloride*	E	E
Iron Chloride*	E	E
Zinc Chloride*	E	E
<b>ALKALINE SALTS:</b>		
Barium Sulfide	E	E
Sodium Bicarbonate	E	E
Sodium Carbonate	E	E
Sodium Sulfide	E	E
Trisodium Phosphate	E	E
<b>NETRAL SALTS:</b>		
Calcium Chloride*	E	E
Magnesium Chloride*	E	E
Potassium Chloride*	E	E
Sodium Chloride*	E	E
<b>SOLVENTS:</b>		
Alcohols	E	E
Aliphatic Hydrocarbons	E	E
Aromatic Hydrocarbons	E	E
Benzene	E	E
Formaldehyde, 37%	E	E
Phenol, 5%	E	G
Mineral Oils	E	E
Vegetable Oils	E	E

KEY: E – no attack  
 G – Appreciably no attack  
 F – some attack, but useable in some instances  
 P – attack, not recommended for use  
 N – rapidly attacked  
 \* - and nitrate and sulfate

## VALVE ACCESSORIES

# M&H AWWA C509 RESILIENT WEDGE GATE VALVES (1993)

### VALVE ACCESSORIES

Mechanical operational accessories are used for valves having special operational needs such as;

1. Location with limited access
2. Hazardous locations
3. Revision of operational position
4. High Torque Operation
5. Indication of Valve Position

Accessory selection must be evaluated for its capability to transmit the required torque requirements to the valve. To assure long-term trouble free operation, its materials of construction should take into account factors relating to corrosion and maintenance.

Accessories used on M&H valves can include the following:

- Electric Motor Operators
- Stem Guides
- Indicator Posts
- Hand wheels
- “T” Handles
- Extension Stems
- Floor Boxes
- Chain Wheels
- Floor stands (Non-rising stem)
- Position Indicators
- Miter Box Gearing
- Electronic Switches

LIMITED WARRANTY

**M&H AWWA C509 RESILIENT WEDGE GATE VALVES (1993)**

**TEN YEAR LIMITED WARRANTY ON M&H VALVE RESILIENT WEDGE GATE VALVES**

M&H Valve Company warrants that its Resilient Wedge Gate Valves will be free from defects in material and workmanship under normal and customary use and maintenance for a period of ten (10) years from the date of purchase, provided the hydrant is installed and maintained according to M&H Valve instructions, and applicable codes. The foregoing warranty does not cover failure of any part or parts from external forces, including but not limited to earthquake, vandalism, vehicular or other impact, application of excessive torque to the operating mechanism or frost heave.

Should any M&H Valve Company part or parts fail to conform to the foregoing warranty, M&H Valve shall, upon prompt written notice thereof, repair, or replace, F.O.B. point of manufacture, such defective part or parts. Purchaser shall, if requested, return the part or parts to M&H Valve, transportation prepaid. Purchaser shall bear all responsibility and expense incurred for removal, reinstallation and shipping in connection with any part supplied under the foregoing warranty.

THE FOREGOING WARRANTY IS IN LIEU OF AND EXCLUDES ALL OTHER WARRANTIES NOT EXPRESSLY SET FORTH HEREIN, WHETHER EXPRESS OR IMPLIED BY OPERATION OF LAW OR OTHERWISE, INCLUDING BUT NOT LIMITED TO ANY WARRANTIES OF MERCHANTABILITY OR FITNESS. IN NO EVENT SHALL M&H VALVE COMPANY BE RESPONSIBLE OR LIABLE FOR ANY INCIDENTAL OR CONSEQUENTIAL LOSSES, DAMAGES OR EXPENSES.

**September 1, 2012 / C509 Gate Valves**

ITEM	DESCRIPTION	MATERIAL	ASTM SPEC.
1	HOLD DOWN HEX BOLT	304 STAINLESS STEEL	ASTM F593C
2	HOLD DOWN BOLT FLAT WASHER	304 STAINLESS STEEL	ASTM F593C
3	OPERATING NUT OR HANDWHEEL	CAST IRON	ASTM A126 CLASS B
4	BOLTS/NUTS (STUFFING BOX)	304 STAINLESS STEEL	ASTM F593C / F594
5	STUFFING BOX/FOLLOWER PLATE	DUCTILE IRON	ASTM A536 70-50-05
6	O-RING (STEM) QTY=3	NBR	-----
7	O-RING (STUFFING BOX)	NBR	-----
8	THRUST WASHER BEARING	DELFIN	-----
9	STEM	MANGANESE BRONZE	ASTM B584 CDA 867
10	HEX HEAD BOLTS & NUTS	304 STAINLESS STEEL	ASTM F593C / F594
11	COVER/BONNET	CAST IRON	ASTM A126 CLASS B
12	STEM NUT	BRONZE (NDZ)	ASTM B763 C99500
13	WEDGE/DISC/GATE	CAST IRON/EPDM COATED	ASTM A126 CLASS B
14	O-RING (COVER)	NBR	-----
15	BODY (ALL TYPES)	CAST IRON	ASTM A126 CLASS B
16	OPTIONAL POST PLATE (3"-12")	CAST IRON	ASTM A126 CLASS B
17	PIPE PLUG (OPTIONAL)	GALVANIZED STEEL	-----

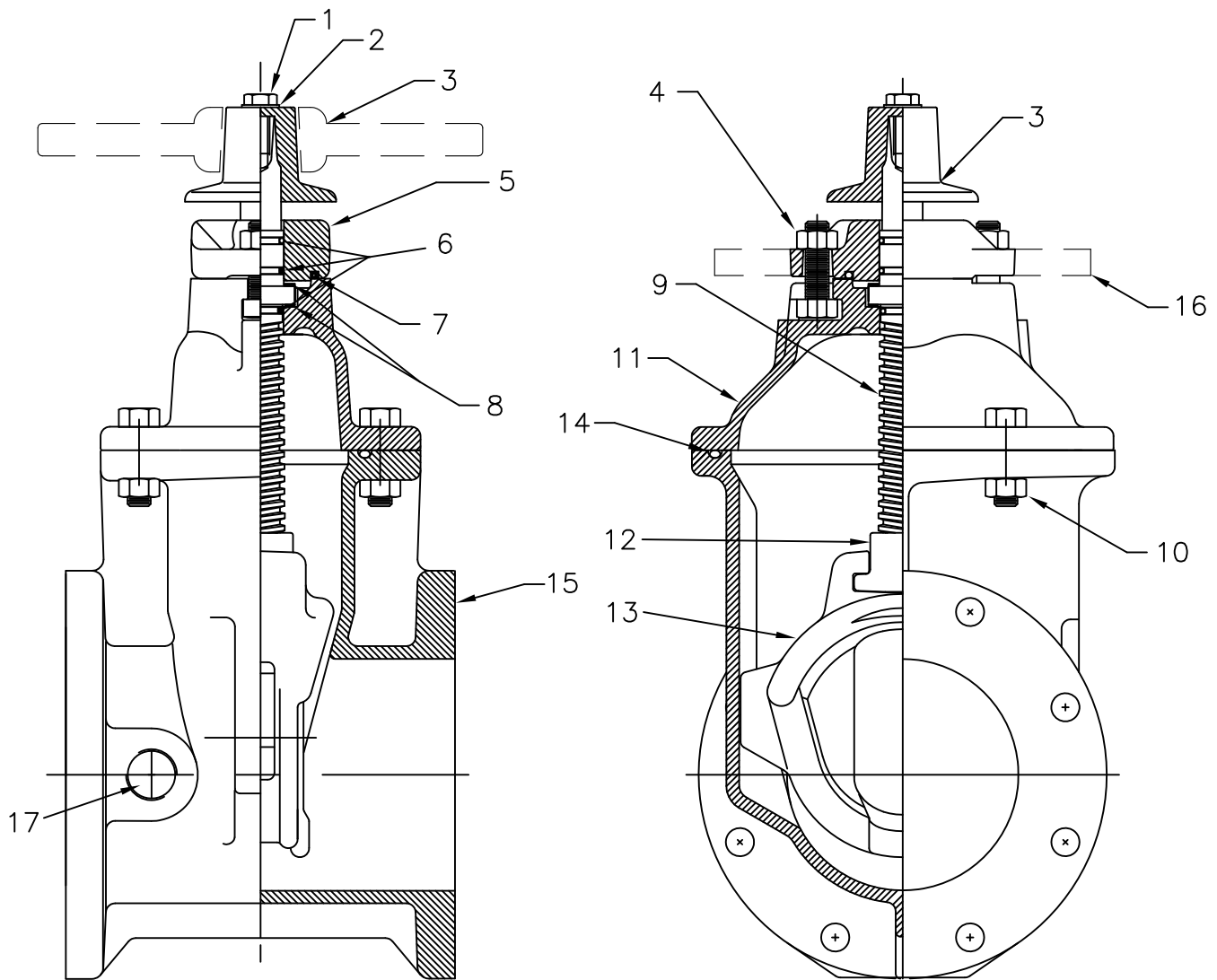

M&H VALVE COMPANY  
ANNISTON, ALABAMA  
A DIVISION OF MCWANE INC.

DWN: TRIJ  
DATE: 9/1/12  
DWG. NO.  
4067

2" THRU 12"  
RESILIENT SEAT GATE VALVE  
C509-NRS-STYLE 4067  
VALVE ASSEMBLY/MATERIAL LIST



ITEM	QTY.	DESCRIPTION	MATERIAL
1	1	HOLD DOWN HEX BOLT	304 STAINLESS STEEL
2	1	HOLD DOWN BOLT FLAT WASHER	304 STAINLESS STEEL
3	1	OPERATING NUT OR HANDWHEEL	CAST IRON
4	2	BOLTS/NUTS (STUFFING BOX)	304 STAINLESS STEEL
5	1	STUFFING BOX/FOLLOWER PLATE	DUCTILE IRON
6	3	O-RING (STEM)	NBR
7	1	O-RING (STUFFING BOX)	NBR
8	1	THRUST WASHER (2" & 2 1/2")	DELTRIN
	2	THRUST WASHER (3"-12")	DELTRIN
9	1	STEM	MANGANESE BRONZE
10	4	HEX HEAD BOLTS/NUTS (2"-6")	304 STAINLESS STEEL
	8	HEX HEAD BOLTS/NUTS (8"-12")	304 STAINLESS STEEL
11	1	COVER/BONNET	CAST IRON
12	1	STEM NUT	BRONZE (NDZ)
13	1	WEDGE/DISC/GATE	CAST IRON/EPDM COATED
14	1	O-RING (COVER)	NBR
15	1	BODY (ALL TYPES)	CAST IRON
16	1	OPTIONAL POST PLATE (3"-12")	CAST IRON
17	1	PIPE PLUG (OPTIONAL)	GALVANIZED STEEL

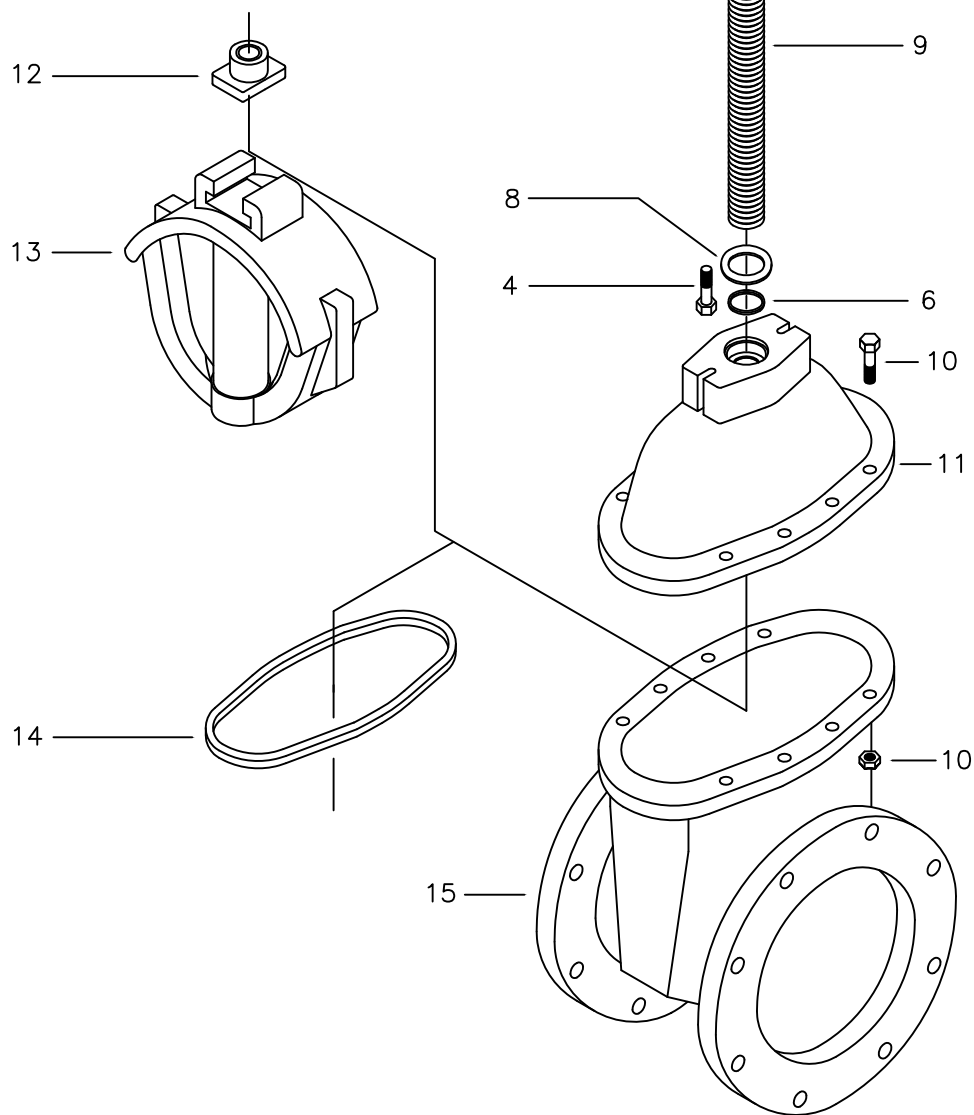

M&H VALVE COMPANY  
ANNISTON, ALABAMA  
A DIVISION OF MCWANE INC.

DWN: TRIJ  
DATE: 9/1/12  
DWG. NO.  
4067EV

2" THRU 12"  
RESILIENT SEAT GATE VALVE  
C509-NRS-STYLE 4067  
ASSEMBLY EXPLOSION



COMPLIES WITH  
APPLICABLE  
REQUIREMENTS OF  
AWWA C509

4067-01 WITH 2" SQUARE NUT  
4067-01HW WITH HANDWHEEL  
4067-01P WITH POST PLATE (3"-12")

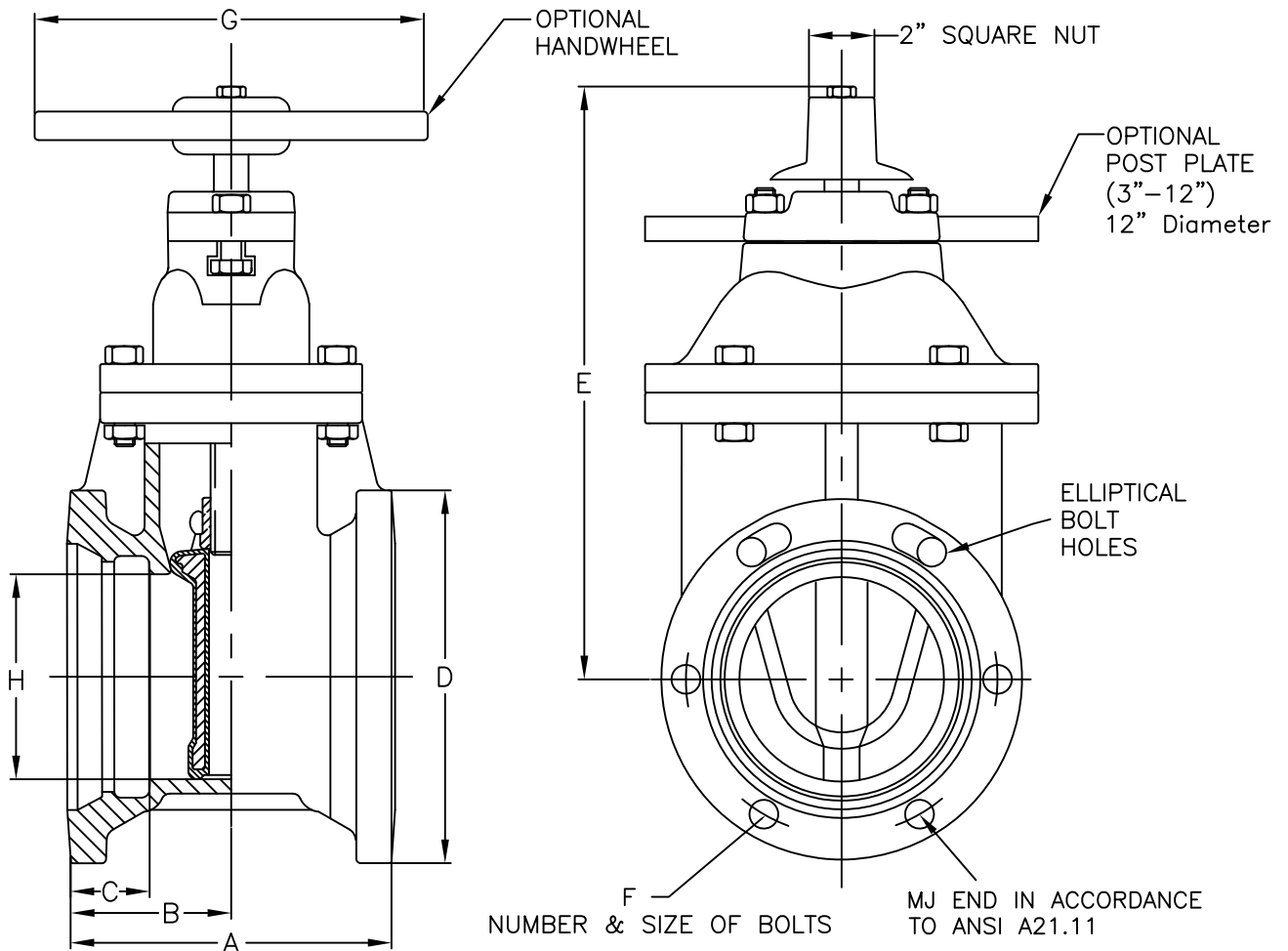

ELLIPTICAL BOLT HOLE DESIGN ALLEVIATES THE NEED FOR ANTI-ROTATIONAL BOLTS

VALVE SIZE	A	B	C	D	E	F	G	H	WEIGHT 2" NUT
**2	8 1/4	4 1/8	2 1/2	4 1/2	10 7/8	4-5/8	7 1/4	2	36
**2 1/2	—	—	—	—	—	—	—	—	—
3	8 1/2	4 1/4	2 1/2	7 3/4	12 3/8	4-5/8	10	3	60
4	9 1/2	4 3/4	2 1/2	9 1/8	14 3/4	4-3/4	10	4 1/4	82
6	10 1/2	5 1/4	2 1/2	11 3/8	19	6-3/4	12	6 1/4	134
8	13 1/8	6 9/16	2 1/2	13 3/4	22 1/2	6-3/4	14	8 1/4	201
10	15 1/2	7 3/4	2 1/2	15 3/4	26 1/2	8-3/4	18	10 1/4	366
12	16	8	2 5/8	18	30	8-3/4	18	12 1/4	481

HANDWHEEL--ADD 1# (2" - 2 1/2"), 6.5# (3"-4"), 7#(6"), 10#(8"), 16#(10" & 12")

INDICATOR POST PLATE ADD 16# (3"-12") ONLY

PALLET QUANTITIES 2" NUT: 46(2 1/2"), 36(3"), 30(4"), 24(6"), 10(8"), 6(10"), 6(12")

PALLET QUANTITIES HANDWHEEL: 36(2" & 2 1/2"), 30(3"), 30(4"), 18(6"), 8(8"), 6(10"), 4(12")

TURNS TO OPEN: 7 3/4(2"), 8(2 1/2"), 10(3"), 13 1/2(4"), 19 1/2(6"),

25 1/2(8"), 31 1/2(10"), 37 3/4(12")

\*\*2" and 2 1/2" not included in AWWA C509

M&H VALVE COMPANY  
ANNISTON, ALABAMA  
A DIVISION OF MCWANE INC.

DWN: TRIJ  
DATE: 9/1/12  
DWG. NO.  
SD-11

2" THRU 12"  
RESILIENT SEAT GATE VALVE  
C509-STYLE 4067-01  
MJ X MJ



COMPLIES WITH  
APPLICABLE  
REQUIREMENTS OF  
AWWA C509

4067-02  
4067-02HW  
4067-02P

WITH 2" SQUARE NUT  
WITH HANDWHEEL  
WITH POST PLATE (3"-12")

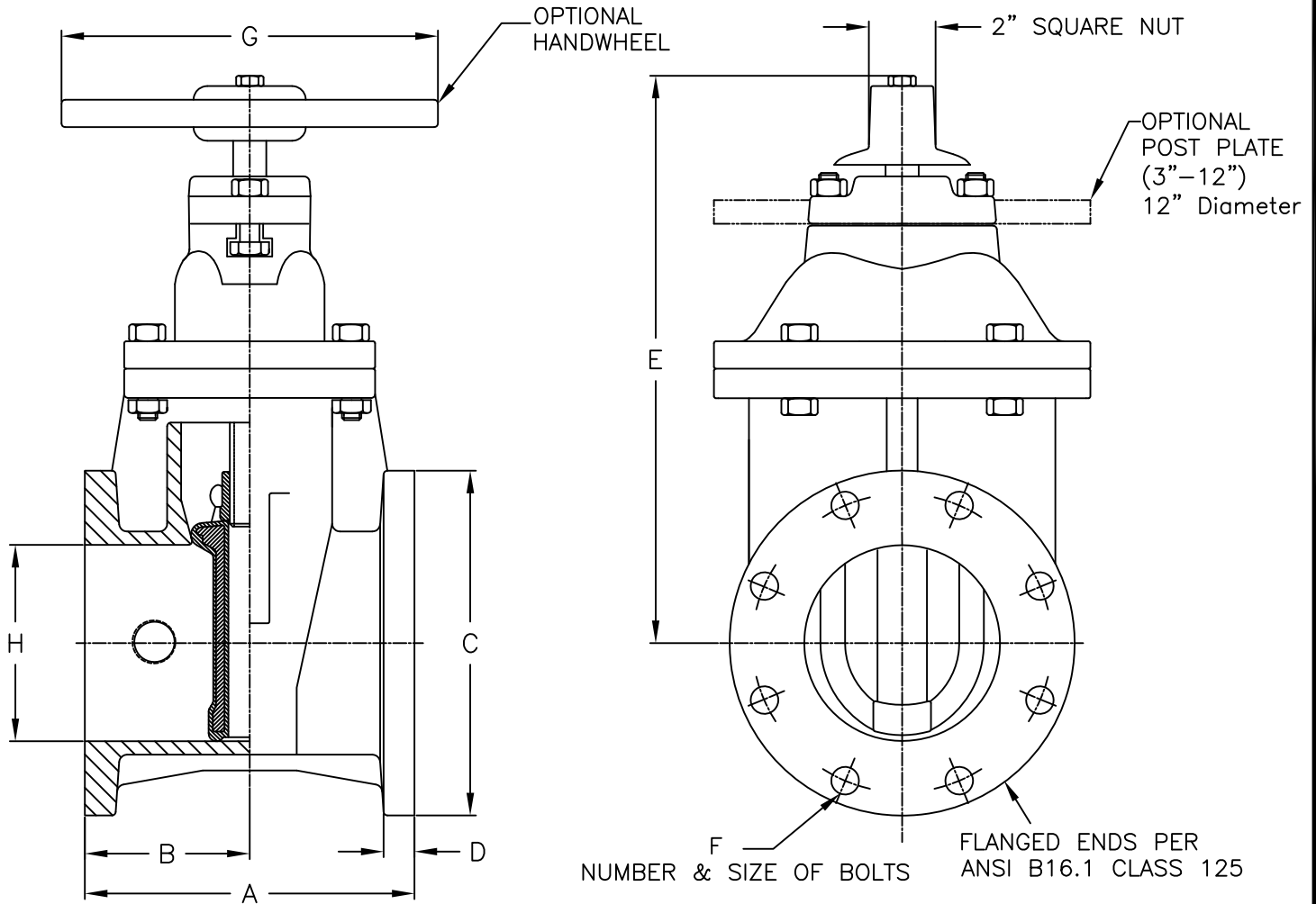

VALVE SIZE	A	B	C	D	E	F	G	H	WEIGHT 2" NUT
**2	7	3 1/2	6	5/8	10 7/8	4-5/8	7 1/4	2	37
**2 1/2	7 1/2	3 3/4	7	11/16	11 3/8	4-5/8	7 1/4	2 1/2	51
3	8	4	7 1/2	3/4	12 3/8	4-5/8	10	3	57
4	9	4 1/2	9	15/16	14 3/4	8-5/8	10	4 1/4	82
6	10 1/2	5 1/4	11	1	19	8-3/4	12	6 1/4	134
8	11 1/2	5 3/4	13 1/2	1 1/8	22 1/2	8-3/4	14	8 1/4	203
10	13	6 1/2	16	1 3/16	26 1/2	12-7/8	18	10 1/4	364
12	14	7	19	1 1/4	30	12-7/8	18	12 1/4	500

HANDWHEEL--ADD 1# (2" - 2 1/2"), 6.5# (3"-4"), 7#(6"), 10#(8"), 16#(10" & 12")  
 INDICATOR POST PLATE ADD 16# (3"-12") ONLY  
 PALLET QUANTITIES 2" NUT: 46(2 1/2"), 36(3"), 30(4"), 24(6"), 10(8"), 6(10"), 6(12")  
 PALLET QUANTITIES HANDWHEEL: 36(2" & 2 1/2"), 30(3"), 30(4"), 18(6"), 8(8"), 6(10"), 4(12")  
 TURNS TO OPEN: 7 3/4(2"), 8(2 1/2"), 10(3"), 13 1/2(4"), 19 1/2(6"),  
 25 1/2(8"), 31 1/2(10"), 37 3/4(12")

\*\*2" and 2 1/2" not included in AWWA C509

M&H VALVE COMPANY  
ANNISTON, ALABAMA  
A DIVISION OF MCWANE INC.

DWN: TRIJ  
DATE: 9/1/12  
DWG. NO.  
SD-9

2" THRU 12"  
RESILIENT SEAT GATE VALVE  
C509-STYLE 4067-02  
FLANGED ENDS