



# ASSEMBLED CAST IRON SLIP VALVE BOX

## Product Features

All valve boxes and related parts shall be coated on all surfaces with an asphaltic varnish of 2mm in thickness.

## Model Numbers

PSVB461AW

PSVB562AW

PSVB564AW

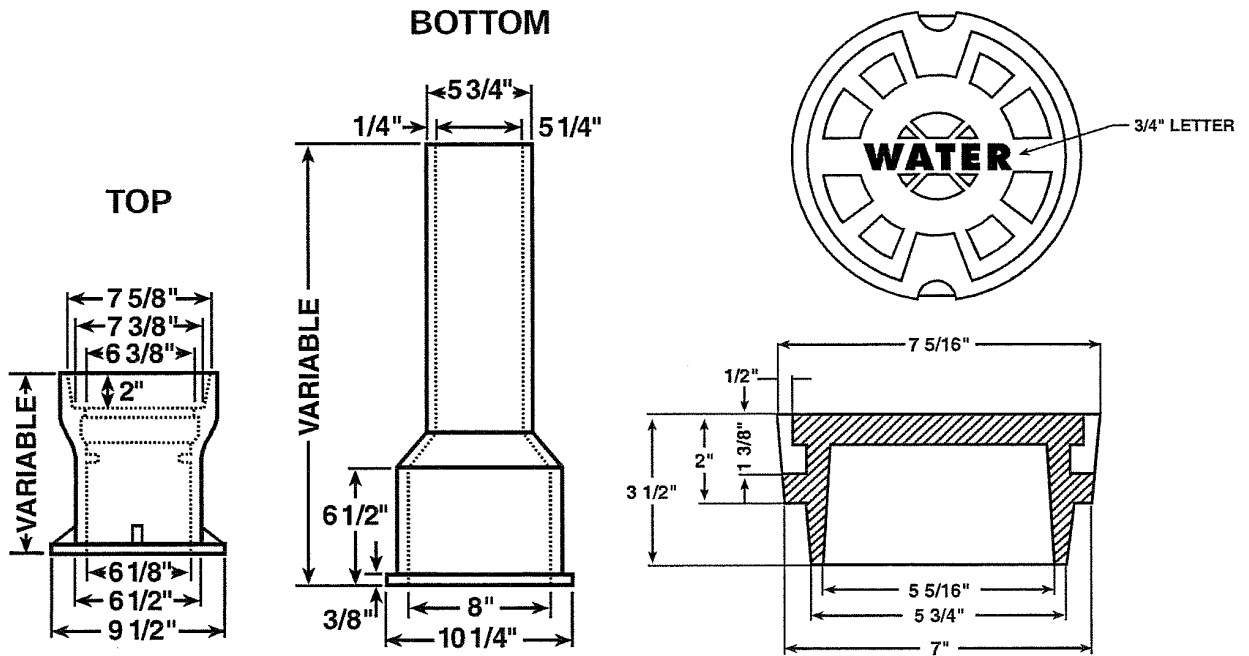

DIMENSIONS/COMPONENTS				
ITEM #	TOP	BOTTOM	LID	RANGE
PSVB461AW	IVBATS10 10"	IVBABS15 15"	IVBLIDW 5-1/4"	20"-24"
PSVB562AW	IVBATS16 16"	IVBABS24 24"	IVBLIDW 5-1/4"	28"-38"
PSVB564AW	IVBATS16 16"	IVBABS36 36"	IVBLIDW 5-1/4"	39"-50"

## Codes and Approvals

Valve boxes conform to ASTM A-48, Grade 30B;  
Asphaltic varnish conforms to AWWA C-104.