

# **DURO**<sup>®</sup> **DYNE**

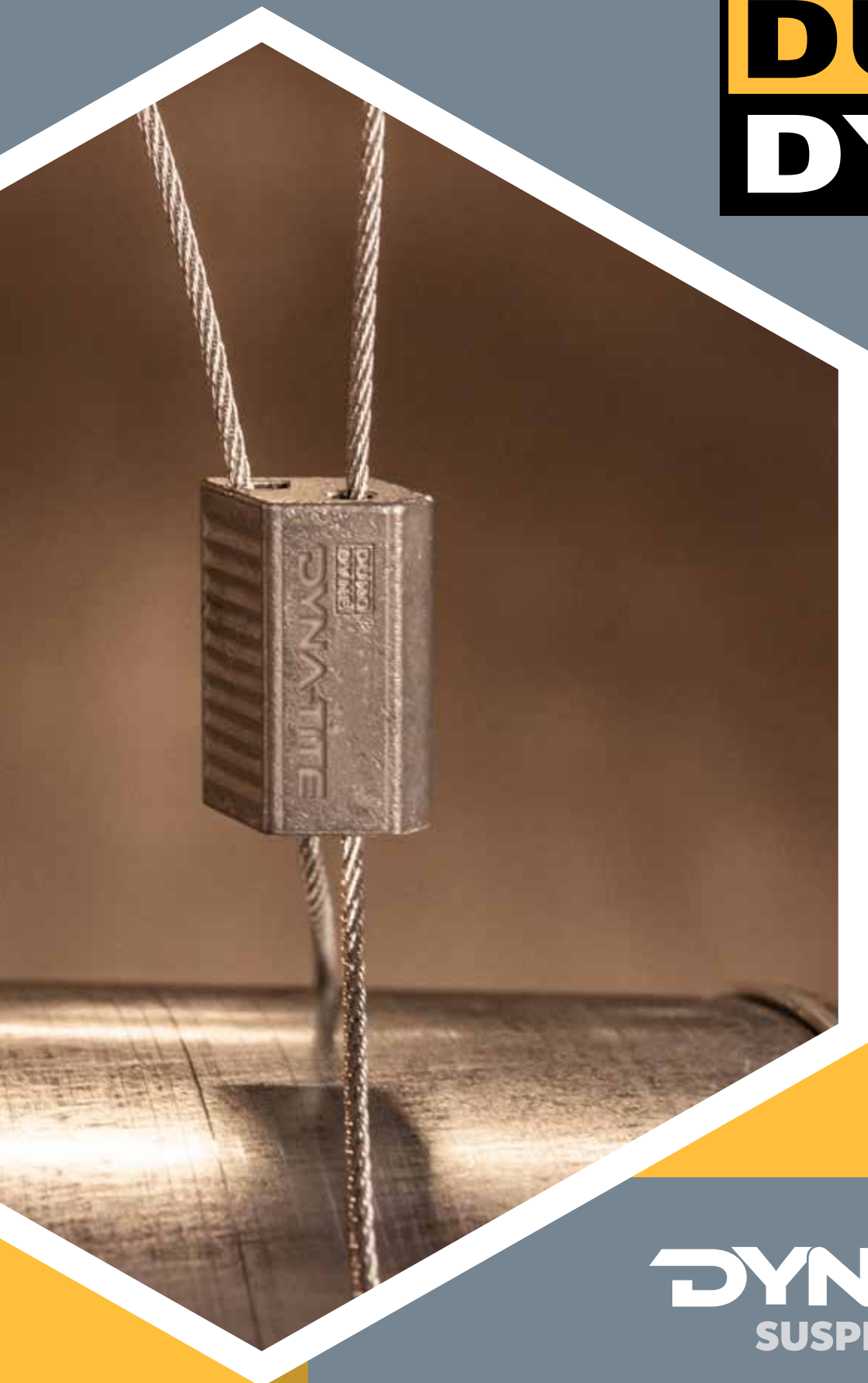

## **DYNATITE**<sup>®</sup> SUSPENSION SYSTEM

**PRODUCT BROCHURE**

# DYNA-TITE®

## Benefits

Its labor saving qualities have been shown to reduce installation time by up to 6x compared to traditional threaded rod.

It provides a fast and strong solution to the task of hanging Mechanical and HVAC Systems.

It allows the installer to position the hangers vertically or at an angle to the suspended object. Always follow Installation Instructions. Hanging at an angle will reduce the safe working load. Please see our "Effects of Hanging at Angles" chart on page 24.

It is lightweight and easy to carry, and combines these qualities with the inherent strength of high tensile wire rope.

Improves safety on the job. Carrying the product on the job site is easy and, in aerial situations, it reduces accident risk caused by falling materials.



**FAST  
SAFE  
PROFESSIONAL  
STRENGTH**

To ensure system integrity, use only with Duro Dyne Dyna-Tite cables. All Cable Locks have been tested to five times their allowable working loads by independent laboratories.

# CABLE LOCKS SUSPENSION SYSTEM

The fast, reliable way to suspend static loads including equipment, ductwork, lighting, sound systems, cable trays, wire baskets, signage and more.



For rectangular ducts

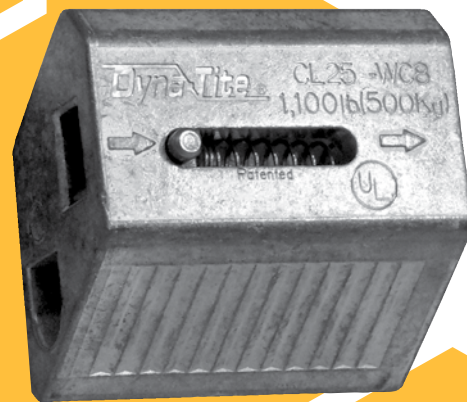

Easily adjustable release pin

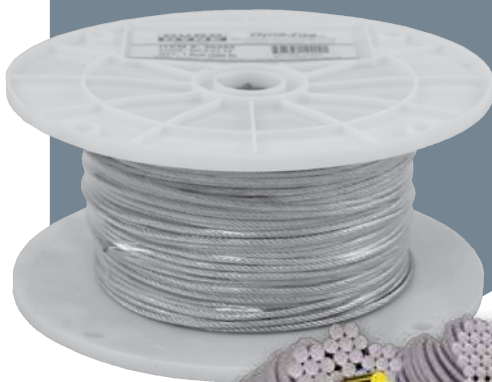

Aviation grade wire rope

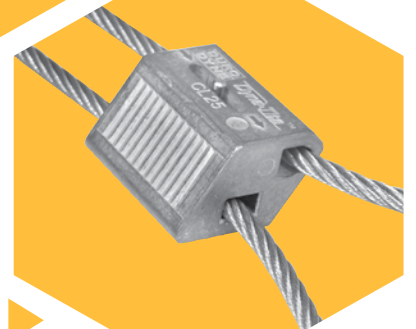

Working Loads up to 1,100 lbs

# DYNA-TITE CABLE LOCKS

Dyna-Tite Cable Locks are a fast and reliable way to suspend ductwork and equipment. All Cable Locks are designed for use with one specific wire size and have working load ranges that incorporate a 5:1 safety factor ratio. For ease of installation Dyna-Tite Cable Locks feature an easy release pin for simple adjustments without the use of tools.



ITEM #	CODE	DESCRIPTION	5:1 SAFE WORKING LOAD	BAG QTY	QTY
R030370	CL3B-WC1	Cable Lock for use w/WC1 Wire	5-35 lbs (3-10 kg)	250	250
31111	CL6-WC2	Cable Lock for use w/WC2 Wire	10-75 lbs (5-34 kg)	10	100
31114	CL12-WC3	Cable Lock for use w/WC3 Wire	25-150 lbs (12-68 kg)	10	100
31116	CL18-WC4	Cable Lock for use w/WC4 Wire	25-250 lbs (12-114 kg)	10	100
31118	CL23-WC6	Cable Lock for use w/WC6 Wire	50-640 lbs (25-291 kg)	10	100
31119	CL25B-WC8	Cable Lock for use w/WC8 Wire	50-1100 lbs (25-500 kg)	50	50

## Cable Locks in Jars

Dyna-Tite Cable Locks are now conveniently packaged in clear jars for ease of display.

ITEM #	CODE	DESCRIPTION	SAFE WORKING LOAD	QTY
31141	JKVFDW-WC2/3-30	JKVFDW-WC2/3 Assembly	25-150 lbs. (12-68 kg)	100
31142	JDSL3-WC3-15	JDSL3-WC3 Strut Lock	25-150 lbs (12-68 kg)	100
31143	JDSL4-WC4-10	JDSL4-WC4 Strut Lock	25-225 lbs (12-102 kg)	100
31144	JCL12-WC3-50	JCL12-WC3 Cable Lock	25-150 lbs (12-68 kg)	50
31145	JCL12-WC3-100	JCL12-WC3 Cable Lock	25-150 lbs (12-68 kg)	50
31146	JCL18-WC4-20	JCL18-WC4 Cable Lock	25-225 lbs (12-102 kg)	100
31147	JCL18-WC4-100	JCL18-WC4 Cable Lock	25-225 lbs (12-102 kg)	100
31148	JCL23-WC6-10	JCL23-WC6 Cable Lock	50-640 lbs (25-291 kg)	100
31149	JCL23-WC6-30	JCL23-WC6 Cable Lock	50-640 lbs (25-291 kg)	50
31150	JCL90-10	JCL90 Cable Lock	25-150 lbs (12-68 kg)	50
31151	JCL90-30	JCL90 Cable Lock	25-150 lbs (12-68 kg)	100



## Locking Cable Locks

Locking Cable Locks, like standard Cable Locks, are to be used on static load applications only. Locking Cable Locks should be used in instances where your static load may be struck by flying objects or experience unexpected movement. The locking bolts on the Locking Cable Locks hold the inside locking wedge in place and disable the release pin feature until the locking bolt is manually loosened.

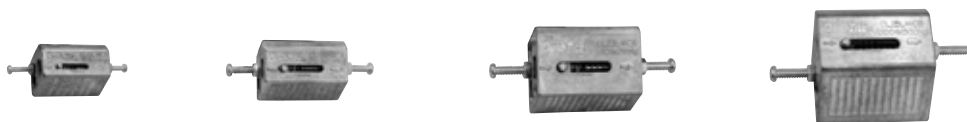

ITEM #	CODE	DESCRIPTION	5:1 SAFE WORKING LOAD	QTY
30369	CL12L-WC3	Locking Cable Lock for use with WC3 Wire Rope	25-150 lbs (12-68 kg)	100
30370	CL18L-WC4	Locking Cable Lock for use with WC4 Wire Rope	25-250 lbs (12-114 kg)	100
30371	CL23L-WC6	Locking Cable Lock for use with WC6 Wire Rope	50-640 lbs (25-291 kg)	100
30372	CL25LB-WC8	Locking Cable Lock for use with WC8 Wire Rope	50-1100 lbs (25-500 kg)	50

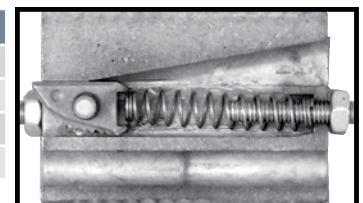

Cutaway inside view of lock

# DYNA-TITE SPECIALTY CABLE LOCKS

## Fast-Locks

Dyna-Tite Fast-Locks have a single way lock instead of a double lock like Cable Locks have and are designed for use with one specific wire size and have working load ranges that incorporate a 4:1 safety factor ratio. For ease of installation, Fast-Locks feature an easy release pin for simple adjustments without the use of tools.



FDM6-WC2



FDM12-WC3



FDM18-WC4

ITEM #	CODE	DESCRIPTION	4:1 SAFE WORKING LOAD	BOX QTY	QTY
30015	FDM6WC2	Fast-Lock for use with WC2 Wire Rope	10-75 lbs (5-34 kg)	10	100
30016	FDM12WC3	Fast-Lock for use with WC3 Wire Rope	25-150 lbs (12-68 kg)	10	100
30017	FDM18WC4	Fast-Lock for use with WC4 Wire Rope	25-250 lbs (12-114 kg)	10	100

\*Dyna-Tite Fast-Lock for use on round ductwork 24" or less diameter

## Strut Lock Assembly

The Strut Lock Assembly is a fast, lockable solution for installing Dyn-O-Strut in single and multi-tiered arrangements for HVAC and cable management. It is ideal for the suspension of rectangular duct, chilled beams, cable tray, unit heaters, etc. The ability to pre-fit the assembly into the strut channel on the ground allows for minimal time working at heights. A threaded release cylinder allows for time saving height adjustment.



ITEM #	CODE	DESCRIPTION	4:1 SAFE WORKING LOAD	BOX QTY	QTY
31080	DSL3Z	Strut Lock Assembly for use with WC3 Wire Rope	25-150 lbs (12-68 kg)	10	100
31081	DSL4Z	Strut Lock Assembly for use with WC4 Wire Rope	25-200 lbs(12-90 kg)	10	100

## CL-90 Square Duct Lock (Patent Pending)

The new Dyna-Tite one piece CL-90 Square Ductwork lock fastens to rectangular ductwork with regular sheet metal screws. Once the lock is attached to the ductwork, the wire rope "drop" is passed into the entry hole at the top of the lock and out the exit hole at the bottom. The locking teeth inside the Cable Lock engage with the cable and secures the ductwork in place. The release pin allows for simple adjustments.

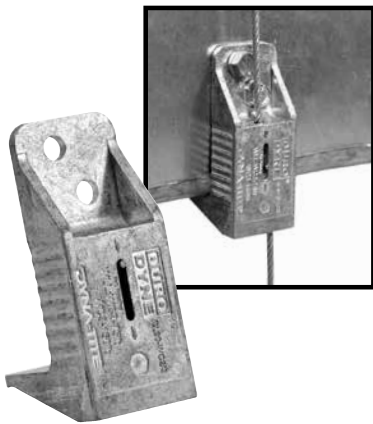

ITEM #	CODE	DESCRIPTION	5:1 SAFE WORKING LOAD WHEN USED WITH WC2	BAG QTY	QTY
30362	CL-90	CL90 Lock for use with WC2 or WC3 Wire Rope	When used with WC2 10-75 lbs (5-34 kg) When used with WC3 25-150 lbs (12-68 kg)	50	150

## KV Bracket Assembly (Patent #7,770,849)

The KV bracket assembly enhances the Dyna-Tite suspension system by the addition of an integral bracket, which fastens the Cable Lock to rectangular ductwork with sheet metal screws. Once the KV assembly bracket is attached to the duct, the wire rope "drop" is passed into the entry hole at the top of the bracket, through the Cable Lock, and out the exit hole at the bottom. The locking teeth inside the Cable Lock engage the wire rope and secure the ductwork in place. An accessible release pin allows for simple adjustments.



ITEM #	CODE	DESCRIPTION	5:1 SAFE WORKING LOAD WHEN USED WITH WC2	QTY
31075	KVFDM	CL90 Lock for use with WC2 or WC3 Wire Rope	When used with WC2 10-75 lbs (5-34 kg) When used with WC3 25-150 lbs (12-68 kg)	100/ctn

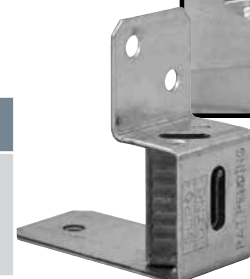

\*To ensure system integrity use only Wire Rope supplied by Duro Dyne. Hanging at angles will reduce the Safe Working Load. Please see the "Effects of Hanging at Angles" chart on page 24.

FOR STATIC LOAD APPLICATIONS ONLY



# DYNA-TITE CABLE, END FITTINGS & KITS



## Cable Lock Wire Rope

Aviation grade galvanized wire rope supplied by Duro Dyne is manufactured to exacting standards and statistically tested to verify stated breaking strengths. Duro Dyne WC1, WC2, WC3 and WC4 wire ropes utilize standard 7x7 construction. WC6 and WC8 wire ropes have a 7x19 construction. All Duro Dyne wire rope spools have a black and yellow thread running through the center of the wire rope, to show that it is genuine Duro Dyne wire rope. Only use wire rope\* supplied by Duro Dyne with Dyna-Tite Cable Locks to ensure maximum safety and integrity of the installation.

ITEM #	CODE	DESCRIPTION	TOLERANCE	CONSTRUCTION	SAFE WORKING LOAD**	QTY
R030387	WC1	For use with CL3-WC1 Cable Lock	+.008/-0.00 in	7x7	5-35 lbs (3-10 kg)	1000 ft/roll
30200	WC2	For use with CL6-WC2 Cable Lock	+.010/-0.005 in	7x7	10-75 lbs (5-34 kg)	500 ft/roll
30202	WC3	For use with CL12-WC3 Cable Lock	+.012/-0.006 in	7x7	25-150 lbs (12-68 kg)	500 ft/roll
30204	WC4	For use with CL18-WC4 Cable Lock	+.014/-0.007 in	7x7	25-250 lbs (12-114 kg)	500 ft/roll
30206	WC6	For use with CL23-WC6 Cable Lock	+.018/-0.009 in	7x19	50-640 lbs (25-291 kg)	250 ft/roll
30208	WC8	For use with CL25-WC8 Cable Lock	+5%/-0%	7x19	50-1,100 lbs (25-500 kg)	250 ft/roll

\*Safe Working Loads are based on a 5:1 Safety Factor.  
 \*\*Hanging at angles will reduce the Safe Working Loads. Please see our 'Effects of Hanging at Angles' table on page 24.



## Starter Kits

The Starter Kit has everything you need to begin hanging ductwork or equipment.

ITEM #	CODE	DESCRIPTION	SAFE WORKING LOAD*
R030398	CL6WC2SK	CL6-WC2 Starter Kit with WC2 Wire Rope	10-75 lbs (5-34 kg)
30394	CL12WC3SK	CL12-WC3 Starter Kit with WC3 Wire Rope	25-250 lbs (12-114 kg)
30393	CL18WC4SK	CL18-WC4 Starter Kit with WC3 Wire Rope	25-150 lbs (12-68 kg)

\*Safe Working Loads are based on a 4:1 Safety Factor.

### Includes:

- ▶ 1 Roll of Wire Rope
- ▶ 100 Cable Locks
- ▶ 1 Cable Cutter

## Contractor Bulk Pack

ITEM #	CODE	DESCRIPTION
31020	CL6WC2CBSK	CL6-WC2 with WC2 Wire Rope
31021	CL12WC3CBSK	CL12-WC3 with WC3 Wire Rope
31022	CL18WC4CBSK	CL18-WC4 with WC4 Wire Rope
31024	WC3CBSK	CL12-WC3 & KVFD with WC3 Wire Rope

### Includes:

- ▶ 2 Rolls of Wire Rope
- ▶ 200 Cable Locks
- ▶ 1 Cable Cutter
- ▶ 1 Self Dispensing Lid



# DYNA-TITE CABLE, END FITTINGS & KITS

## Looped Cable Assembly

Looped Cable Assembly enhances the Dyna-Tite suspension system by the addition of a pre-looped cable end. Once the wire rope is pulled around the anchor point and through the looped end of the cable, it is already secured at one end, saving time at the jobsite. The remaining wire rope “drop” is passed through a channel in the Dyna-Tite Cable Lock. Then, the wire rope is either wrapped around the ductwork or inserted through a fastening point and back up into the second channel of the same Cable Lock. The locking teeth inside the Cable Lock engage the wire rope which secures the ductwork in place.

**Note:**  
Kit includes Cable Lock



ITEM #	CODE	ITEM# FOR KIT	ITEM# FOR2 PACK KIT	DESCRIPTION	FOR USE WITH CABLE LOCK	SAFE WORKING LOAD*+	BOX QTY	QTY
R030195	LC05WC1	•	R031040	5 ft Looped WC1 Cable 2 Pack Kit	CL3-WC1	5-35 lbs (3-10 kg)	10	100
R030196	LC10WC1	•	R031041	10 ft Looped WC1 Cable 2 Pack Kit	CL3-WC1	5-35 lbs (3-10 kg)	10	100
R030197	LC15WC1	•	R031042	15 ft Looped WC1 Cable 2 Pack Kit	CL3-WC1	5-35 lbs (3-10 kg)	10	100
R030198	LC25WC1	•	R031045	25 ft Looped WC1 Cable 2 Pack Kit	CL3-WC1	5-35 lbs (3-10 kg)	5	50
30213	LC05WC2	30181	R030199	5 ft Looped WC2 Cable	CL6-WC2	10-75 lbs (5-34 kg)	10	100
30214	LC10WC2	30182	R030260	10 ft Looped WC2 Cable	CL6-WC2	10-75 lbs (5-34 kg)	10	100
30215	LC15WC2	30183	R030261	15 ft Looped WC2 Cable	CL6-WC2	10-75 lbs (5-34 kg)	10	100
30216	LC25WC2	30184	R030172	25 ft Looped WC2 Cable	CL6-WC2	10-75 lbs (5-34 kg)	5	50
30228	LC05WC3	30185	•	5 ft Looped WC3 Cable	CL12-WC3	25-150 lbs (12-68 kg)	10	100
30229	LC10WC3	30186	•	10 ft Looped WC3 Cable	CL12-WC3	25-150 lbs (12-68 kg)	10	100
30230	LC15WC3	30187	•	15 ft Looped WC3 Cable	CL12-WC3	25-150 lbs (12-68 kg)	10	100
30232	LC25WC3	30188	•	25 ft Looped WC3 Cable	CL12-WC3	25-150 lbs (12-68 kg)	5	50
•	LC30WC3	30134	•	30 ft Looped WC3 Cable	CL12-WC3	25-150 lbs (12-68 kg)	5	50
30233	LC05WC4	30193	•	5 ft Looped WC4 Cable	CL18-WC4	25-250 lbs (12-114 kg)	5	50
30234	LC10WC4	30194	•	10 ft Looped WC4 Cable	CL18-WC4	25-250 lbs (12-114 kg)	10	100
30235	LC15WC4	30195	•	15 ft Looped WC4 Cable	CL18-WC4	25-250 lbs (12-114 kg)	10	100
30237	LC25WC4	30196	•	25 ft Looped WC4 Cable	CL18-WC4	25-250 lbs (12-114 kg)	5	50
30209	LC05WC6	•	•	5 ft Looped WC6 Cable	CL23-WC6	50-640 lbs (25-291 kg)	10	100
30210	LC10WC6	•	•	10 ft Looped WC6 Cable	CL23-WC6	50-640 lbs (25-291 kg)	10	100
30211	LC15WC6	•	•	15 ft Looped WC6 Cable	CL23-WC6	50-640 lbs (25-291 kg)	5	50
30212	LC25WC6	•	•	25 ft Looped WC6 Cable	CL23-WC6	50-640 lbs (25-291 kg)	5	50

\*Safe Working Loads are based on a 5:1 Safety Factor.

+Hanging at angles will reduce the Safe Working Loads. Please see our 'Effects of Hanging at Angles' table on page 24.

# DYNA-TITE CABLE, END FITTINGS & KITS

## KV Bracket Assembly With Looped Cable Kits

The KV bracket assembly enhances the Dyna-Tite suspension system by the addition of an integral bracket, which fastens the Cable Lock to rectangular ductwork with sheet metal screws. Once the KV assembly bracket is attached to the duct, the wire rope “drop” is passed into the entry hole at the top of the bracket, through the Cable Lock, and out the exit hole at the bottom. The locking teeth inside the Cable Lock engage the wire rope and secure the ductwork in place. An accessible release pin allows for simple adjustments.

ITEM #	CODE	DESCRIPTION	QTY
31010	LC12K05WC3/FDMK	5 ft 1-1/2in Looped w/KV Bracket Assembly	100 kits/ctn
31071	LC12K10WC3/FDMK	10 ft 1-1/2in Looped w/KV Bracket Assembly	100 kits/ctn
31072	LC12K15WC3/FDMK	15 ft 1-1/2in Looped w/KV Bracket Assembly	100 kits/ctn
31074	LC12K25WC3/FDMK	25 ft 1-1/2in Looped w/KV Bracket Assembly	50 kits/ctn

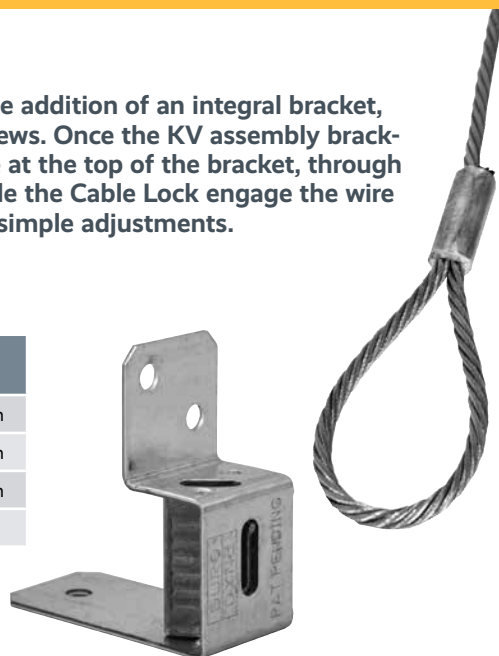

## Eyelets

Duro Dyne Dyna-Tite eyelets are manufactured of zinc plated cold rolled steel and swaged to the wire rope cable with a hydraulic press. Dyna-Tite Eyelet assemblies are available for installation with either a 1/4 in or 3/8 in fastener. They are available in 45°, 90° and straight variations and can also be purchased as a kit with the appropriate Cable Lock.



CABLE LOCK	WIRE ROPE	SAFE WORKING LOAD*+
CL6-WC2	WC2	10-75 lbs(5-34 kg)
CL12-WC3	WC3	25-150 lbs (12-68 kg)
CL18-WC4	WC4	25-250 lbs(12-114 kg)

\*Safe Working Loads are based on a 5:1 Safety Factor.  
+Hanging at angles will reduce the Safe Working Loads. Please see our 'Effects of Hanging at Angles' table on page 24.



90° 3/8 in Eyelet



90° 1/4 in Eyelet

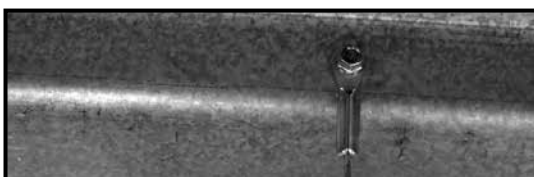

1/4 in Straight Eyelet



45° 1/4 in Eyelet

Available individually or conveniently packaged in kits with the appropriate Dyna-Tite Cable Locks.

# DYNA-TITE CABLE, END FITTINGS & KITS

## Eyelet Cables and Kits (Kit includes lock)



### 1/4 in Eyelets

DESCRIPTION	QTY	ITEM #	CODE	ITEM # FOR KIT	ITEM #	CODE	ITEM # FOR KIT	ITEM #	CODE
5 ft WC2-CL6 Wire Rope	10/bag-10bg/ctn	30140	9014-05WC2	30240	30161	4514-05WC2	30288	30110	S14-05WC2
10 ft WC2-CL6 Wire Rope	10/bag-10bg/ctn	30141	9014-10WC2	30241	30162	4514-10WC2	30289	30111	S14-10WC2
15 ft WC2-CL6 Wire Rope	10/bag-10bg/ctn	30142	9014-15WC2	30242	•	4514-15WC2	30290	30116	S14-15WC2
25 ft WC2-CL6 Wire Rope	5/bag-10bg/ctn	30143	9014-25WC2	30243	30164	4514-25WC2	30291	•	S14-25WC2
5 ft WC3-CL12 Wire Rope	10/bag-10bg/ctn	30144	9014-05WC3	30244	30165	4514-05WC3	30299	30122	S14-05WC3
10 ft WC3-CL12 Wire Rope	10/bag-10bg/ctn	30145	9014-10WC3	30245	30166	4514-10WC3	30300	30123	S14-10WC3
15 ft WC3-CL12 Wire Rope	10/bag-10bg/ctn	30146	9014-15WC3	30246	30167	4514-15WC3	30301	30128	S14-15WC3
25 ft WC3-CL12 Wire Rope	5/bag-10bg/ctn	30147	9014-25WC3	30247	30168	4514-25WC3	30303	30129	S14-25WC3
5 ft WC4-CL18 Wire Rope	10/bag-10bg/ctn	30148	9014-05WC4	30263	30169	4514-05WC4	30308		Special Order
10 ft WC4-CL18 Wire Rope	10/bag-10bg/ctn	30149	9014-10WC4	30264	30170	4514-10WC4	30309		Special Order
15 ft WC4-CL18 Wire Rope	10/bag-10bg/ctn	30150	9014-15WC4	30265	•	4514-15WC4	30310		Special Order
25 ft WC4-CL18 Wire Rope	5/bag-10bg/ctn	30151	9014-25WC4	30266	•	4514-25WC4	30311		Special Order

### 3/8 in Eyelets

5 ft WC3-CL12 Wire Rope	10/bag-10bg/ctn	30152	9038-05WC3	30271	•	4538-05WC3	30319		Special Order
10 ft WC3-CL12 Wire Rope	10/bag-10bg/ctn	30153	9038-10WC3	30272	30174	4538-10WC3	30320		Special Order
15 ft WC3-CL12 Wire Rope	10/bag-10bg/ctn	30154	9038-15WC3	30273	30175	4538-15WC3	30321		Special Order
25 ft WC3-CL12 Wire Rope	5/bag-10bg/ctn	30155	9038-25WC3	30274	30176	4538-25WC3	30322		Special Order
5 ft WC4-CL18 Wire Rope	10/bag-10bg/ctn	30157	9038-05WC4	30279	30177	4538-05WC4	30329		Special Order
10 ft WC4-CL18 Wire Rope	10/bag-10bg/ctn	30158	9038-10WC4	30280	•	4538-10WC4	30331		Special Order
15 ft WC4-CL18 Wire Rope	10/bag-10bg/ctn	30159	9038-15WC4	30281	30179	4538-15WC4	30332		Special Order
25 ft WC4-CL18 Wire Rope	5/bag-10bg/ctn	30160	9038-25WC4	•	30180	4538-25WC4	30333		Special Order

See previous page for Safe Working Loads.

# DYNA-TITE CABLE, END FITTINGS & KITS

## Dyna-Stud®

The Dyna-Stud is a heavy duty swaged threaded stud with an aircraft-rated cable attached. The stud is threaded into the expansion anchor without putting stress on the cable. This makes for a much safer and tighter connection. The other end of the cable, in conjunction with the Cable Lock, is used to attach the object being supported.

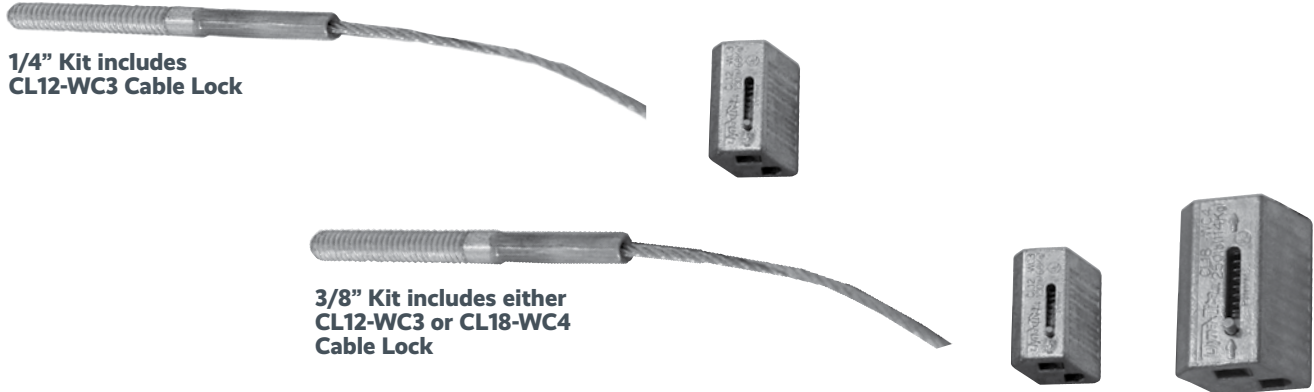

ITEM #	CODE	ITEM # FOR KIT	DESCRIPTION	FOR USE WITH CABLE LOCK	SAFE WORKING LOAD**	BOX QTY	QTY
30052	SDS1405WC3	30377	1/4 in Swaged Threaded Stud x 5 ft WC3-CL12 Cable Assembly	CL12-WC3	25-150 lbs (12-68 kg)	10	100
30053	SDS1410WC3	30378	1/4 in Swaged Threaded Stud x 10 ft WC3-CL12 Cable Assembly	CL12-WC3	25-150 lbs (12-68 kg)	10	100
30054	SDS1415WC3	30379	1/4 in Swaged Threaded Stud x 15 ft WC3-CL12 Cable Assembly	CL12-WC3	25-150 lbs (12-68 kg)	10	100
30055	SDS1425WC3	30380	1/4 in Swaged Threaded Stud x 25 ft WC3-CL12 Cable Assembly	CL12-WC3	25-150 lbs (12-68 kg)	5	50
30373	SDS3805WC3	30003	3/8 in Swaged Threaded Stud X 5 ft WC3-CL12 Cable Assembly	CL12-WC3	25-150 lbs (12-68 kg)	10	100
30374	SDSA3810WC3	30005	3/8 in Swaged Threaded Stud X 10 ft WC3-CL12 Cable Assembly	CL12-WC3	25-150 lbs (12-68 kg)	10	100
30375	SDS3815WC3	30009	3/8 in Swaged Threaded Stud X 15 ft WC3-CL12 Cable Assembly	CL12-WC3	25-150 lbs (12-68 kg)	10	100
30376	SDS3825WC3	30028	3/8 in Swaged Threaded Stud X 25 ft WC3-CL12 Cable Assembly	CL12-WC3	25-150 lbs (12-68 kg)	5	50
30056	SDS3805WC4	30381	3/8 in Swaged Threaded Stud x 5 ft WC4-CL18 Cable Assembly	CL18-WC4	25-225 lbs (12-102 kg)	10	100
30057	SDS3810WC4	30382	3/8 in Swaged Threaded Stud x 10 ft WC4-CL18 Cable Assembly	CL18-WC4	25-225 lbs (12-102 kg)	10	100
30058	SDS3815WC4	30383	3/8 in Swaged Threaded Stud x 15 ft WC4-CL18 Cable Assembly	CL18-WC4	25-225 lbs (12-102 kg)	10	100
30059	SDS3825WC4	30384	3/8 in Swaged Threaded Stud x 25 ft WC4-CL18 Cable Assembly	CL18-WC4	25-225 lbs (12-102 kg)	5	50
30095	SDS3805WC6	•	3/8 in Swaged Threaded Stud x 5 ft WC6-CL23 Cable Assembly	CL23-WC6	50-640 lbs (25-291 kg)	10	100
30096	SDS3810WC6	•	3/8 in Swaged Threaded Stud x 10 ft WC6-CL23 Cable Assembly	CL23-WC6	50-640 lbs (25-291 kg)	10	100
30097	SDS3815WC6	•	3/8 in Swaged Threaded Stud x 15 ft WC6-CL23 Cable Assembly	CL23-WC6	50-640 lbs (25-291 kg)	10	100
30098	SDS3825WC6	•	3/8 in Swaged Threaded Stud x 25 ft WC6-CL23 Cable Assembly	CL23-WC6	50-640 lbs (25-291 kg)	5	50

\*Safe Working Loads are based on a 5:1 Safety Factor.

+Hanging at angles will reduce the Safe Working Loads. Please see our 'Effects of Hanging at Angles' table on page 24.



## 90° Angle Bracket with Drive Pin

The 90° Angle Bracket with Drive Pin comes in 4 different lengths. Complete system includes looped wire and bracket with pre-assembled drive pin. It quickly and easily attaches to concrete, steel or composite metal decking.

ITEM #	CODE	DESCRIPTION	FOR USE W/ CABLE LOCK	SAFE WORKING LOAD**	BOX QTY	QTY
30033	DP90-05WC2	5 ft WC2 Cable w/ 90 Degree Bracket and Drive Pin	CL6-WC2	10-75 lbs (5-34 kg)	10	100
30034	DP90-10WC2	10 ft WC2 Cable w/90 Degree Bracket and Drive Pin	CL6-WC2	10-75 lbs (5-34 kg)	10	100
30035	DP90-15WC2	15 ft WC2 Cable w/90 Degree bracket and Drive Pin	CL6-WC2	10-75 lbs (5-34 kg)	10	100
30036	DP90-25WC2	25 ft WC2 Cable w/90 Degree bracket and Drive Pin	CL6-WC2	10-75 lbs (5-34 kg)	5	50
31005	DP90-05WC3	5 ft WC3 Cable w/ 90 Degree Bracket and Drive Pin	CL12-WC3	25-150 lbs (12-68 kg)	5	25
31006	DP90-10WC3	10 ft WC3 Cable w/ 90 Degree Bracket and Drive Pin	CL12-WC3	25-150 lbs (12-68 kg)	5	25
31007	DP90-15WC3	15 ft WC3 Cable w/ 90 Degree Bracket and Drive Pin	CL12-WC3	25-150 lbs (12-68 kg)	5	25
31008	DP90-25WC3	25 ft WC3 Cable w/ 90 Degree Bracket and Drive Pin	CL12-WC3	25-150 lbs (12-68 kg)	5	25

\*Safe Working Loads are based on a 5:1 Safety Factor.  
+Hanging at angles will reduce the Safe Working Loads. Please see our 'Effects of Hanging at Angles' table on page 24.

## NitroSet 90° Drive Pin

The NitroSet 90° Drive Pin comes in 5 different lengths. Complete system includes looped wire and bracket with pre-assembled drive pin. It quickly and easily attaches to concrete, steel or composite metal decking. Attached to the Nitroset pin CLD90-525.

ITEM #	CODE	DESCRIPTION	FOR USE W/ CABLE LOCK	SAFE WORKING LOAD**	BOX QTY	QTY
31013	NS90525-05WC2	5 ft WC2 Cable w/ Nitroset 90 Degree Drive Pin	CL6-WC2	10-75 lbs (5-34 kg)	10	100
31014	NS90525-10WC2	10 ft WC2 Cable w/ Nitroset 90 Degree Drive Pin	CL6-WC2	10-75 lbs (5-34 kg)	10	100
31015	NS90525-15WC2	15 ft WC2 Cable w/ Nitroset 90 Degree Drive Pin	CL6-WC2	10-75 lbs (5-34 kg)	10	100
31016	NS90525-20WC2	20 ft WC2 Cable w/ Nitroset 90 Degree Drive Pin	CL6-WC2	10-75 lbs (5-34 kg)	5	50
31017	NS90525-25WC2	25 ft WC2 Cable w/ Nitroset 90 Degree Drive Pin	CL6-WC2	10-75 lbs (5-34 kg)	5	50
31023	NS90525-05WC3	5 ft WC3 Cable w/ Nitroset 90 Degree Drive Pin	CL12-WC3	25-150 lbs (12-68kg)	10	100
31025	NS90525-10WC3	10 ft WC3 Cable w/ Nitroset 90 Degree Drive Pin	CL12-WC3	25-150 lbs (12-68kg)	10	100
31026	NS90525-15WC3	15 ft WC3 Cable w/ Nitroset 90 Degree Drive Pin	CL12-WC3	25-150 lbs (12-68kg)	10	100
31027	NS90525-20WC3	20 ft WC3 Cable w/ Nitroset 90 Degree Drive Pin	CL12-WC3	25-150 lbs (12-68kg)	5	50
31028	NS90525-25WC3	25 ft WC2 Cable w/ Nitroset 90 Degree Drive Pin	CL12-WC3	25-150 lbs (12-68kg)	5	50

\*Safe Working Loads are based on a 5:1 Safety Factor.  
+Hanging at angles will reduce the Safe Working Loads. Please see our 'Effects of Hanging at Angles' table on page 24.

## Wedge Anchor

The anchor measures 2" in overall length and 1/4" in diameter, with a minimum depth of 1 3/8", used with WC3 cable.

ITEM #	CODE	DESCRIPTION	FOR USE W CABLE LOCK	SAFE WORKING LOAD**	BOX QTY	QTY
30018	JTWA05WC3	5 ft WC3 Cable Assembly	CL12-WC3	25-150 lbs (12-68 kg)	10	100
30019	JTWA10WC3	10 ft WC3 Cable Assembly	CL12-WC3	25-150 lbs (12-68 kg)	10	100
30084	JTWA15WC3	15 ft WC3 Cable Assembly	CL12-WC3	25-150 lbs (12-68 kg)	10	100
30085	JTWA25WC3	25 ft WC3 Cable Assembly	CL12-WC3	25-150 lbs (12-68 kg)	10	100

\*Safe Working Loads are based on a 5:1 Safety Factor.  
+Hanging at angles will reduce the Safe Working Loads. Please see our 'Effects of Hanging at Angles' table on page 24.



# DYNA-TITE CABLE, END FITTINGS & KITS

## Toggle

The Dyna-Tite Toggle is a quick and easy way to establish a fixed end through a drilled or punched hole in the ceiling deck. For use with CL12-WC3 Cable Lock, DSL3 Strut Lock, KV12 Bracket Assembly or any other Dyna-Tite WC3 Cable Lock. Ensure that the hole is no larger than 7/16" in diameter. For static load applications only.

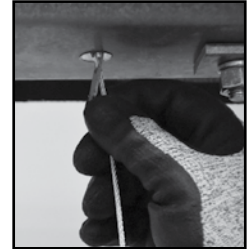
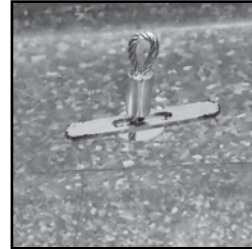

ITEM #	CODE	DESCRIPTION	FOR USE WITH CABLE LOCK	BOX QTY	QTY
30353	ST05WC2	5 ft Single Toggle WC2	CL6-WC2	10	100
R030280	ST10WC2	10 ft Single Toggle WC2	CL6-WC2	10	100
R030278	ST20WC2	20 ft Single Toggle WC2	CL6-WC2	10	100
R030163	ST25WC2	25 ft Single Toggle WC2	CL6-WC2	10	100
31046	ST05WC3	5 ft Single Toggle WC3	CL12-WC3	10	100
31047	ST10WC3	10 ft Single Toggle WC3	CL12-WC3	10	100
31048	ST15WC3	15 ft Single Toggle WC3	CL12-WC3	10	100
31049	ST25WC3	25 ft Single Toggle WC3	CL12-WC3	10	100

## Toggle Cables

ITEM #	CODE	DESCRIPTION	BOX QTY	QTY
<b>Y TOGGLE CABLES</b>				
R030281	RWC2Y18T5	WC2 Cable 5 ft-18 in Y Toggle	10	100
R030275	RWC2Y12T10	WC2 Cable 10 ft-12 in Y Toggle	10	100
R030284	RWC2Y18T10	WC2 Cable 10 ft-18 in Y Toggle	10	100
R030283	RWC2Y18T15	WC2 Cable 15 ft-18 in Y Toggle	10	100
R030273	RWC2Y18T20	WC2 Cable 20 ft-18 in Y Toggle	10	100
<b>V TOGGLE CABLES</b>				
R030267	RWC2V6T	WC2 6 in Cable Loop V Toggle	10	100
R030270	RWC2V18T	WC2 18 in Cable Loop V Toggle	10	100

## Toggle Cable Kits

ITEM #	CODE	DESCRIPTION	BOX QTY	QTY
<b>SINGLE TOGGLE CABLE KITS</b>				
R030264	RWC2S10TK	(2) WC2 Single Cable 10 ft w/Toggle & (2) CL6 Kit	1	10
R030263	RWC2S20TK	(2) WC2 Single Cable 20 ft w/Toggle & (2) CL6 Kit	1	5
<b>Y TOGGLE CABLE KITS</b>				
R030274	RWC2Y12T10	(2) WC2 x 10 ft 12 in Y Toggle & (2) CL6 Kit	1	10
R030194	RWC2Y18T5	(2) WC2 Cable 5 ft-18 in Y Toggle & (2) CL6 Kit	1	10
R030202	RWC2Y18T10	(2) WC2 Cable 10 ft-18 in Y Toggle & (2) CL6 Kit	1	10
R030205	RWC2Y18T15	(2) WC2 Cable 15 ft-18 in Y Toggle & (2) CL6 Kit	1	5
R030200	RWC2Y18T20	(2) WC2 Cable 20 ft-18 in Y Toggle & (2) CL6 Kit	1	5

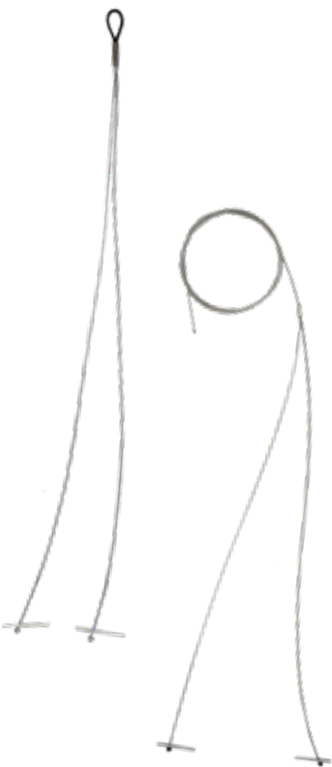

# DYNA-TITE CABLE, END FITTINGS & KITS

## Snap Hook

Snap hooks offer easy attachment points and are ideal for applications that require constant inspection or maintenance that may require you to remove the load from the ceiling.

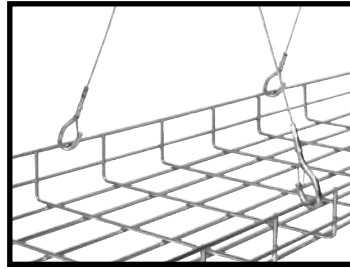

ITEM #	CODE	DESCRIPTION	FOR USE W/ CABLE LOCK	SAFE WORKING LOAD**	BAG QTY	QTY
RO30072	SH05WC2	5 ft WC2 Cable	CL6-WC2	10-75 lbs (5-34 kg)	10	50
30217	SH05WC3	5 ft WC3 Cable	CL12-WC3	25-150 lbs (12-68 kg)	10	50
30218	SH10WC3	10 ft WC3 Cable	CL12-WC3	25-150 lbs (12-68 kg)	10	50
30219	SH15WC3	15 ft WC3 Cable	CL12-WC3	25-150 lbs (12-68 kg)	10	50
30223	SH25WC3	25 ft WC3 Cable	CL12-WC3	25-150 lbs (12-68 kg)	5	25

## Y Snap Hook Cable Kit

ITEM #	CODE	DESCRIPTION	BAG QTY	QTY
RO30117	RWC2Y18SH5	5 ft WC2 18 in Y Snap Hook Cable Assembly Only	10	100
RO30118	RWC2Y18SH10	10 ft WC2 18 in Y Snap Hook Cable Assembly	10	100
RO30119	RWC2Y18SH15	15 ft WC2 18 in Y Snap Hook Cable Assembly	10	100
RO30186	RWC3Y18SH5	5 ft WC3 18 in Y Snap Hook Cable Assembly	10	100
RO30269	RWC3Y18SH10	10 ft WC3 18 in Y Snap Hook Cable assembly only	10	100
RO30272	RWC3Y18SH15	15 ft WC3 18 in Y Snap Hook Cable assembly only	10	100
RO30268	RWC3L18VH	WC3 Cable Loop 18 in V Snap Hook	10	100
RO30081	RWC2Y18SH5K	5 ft WC2 18 in Y Snap Hook Kit w/ 2 locks and 2 cables	1	50
RO30013	RWC2Y18SH10K	10 ft WC2 18 in Y Snap Hook Kit w/ 2 locks and 2 cables	1	50
RO30083	RWC2Y18SH15K	15 ft WC2 18 in Y Snap Hook Kit w/ 2 locks and 2 cables	1	50
RO30187	RWC3Y18SH5K	5 ft WC3 18 in Y Snap Hook Kit w/ 2 locks and 2 cables	1	50
RO30201	RWC3Y18SH10K	10 ft WC3 18 in Y Snap Hook Kit w/ 2 locks and 2 cables	1	50
RO30266	RWC3Y18SH15K	15 ft WC3 18 in Y Snap Hook Kit w/ 2 locks and 2 cables	1	50

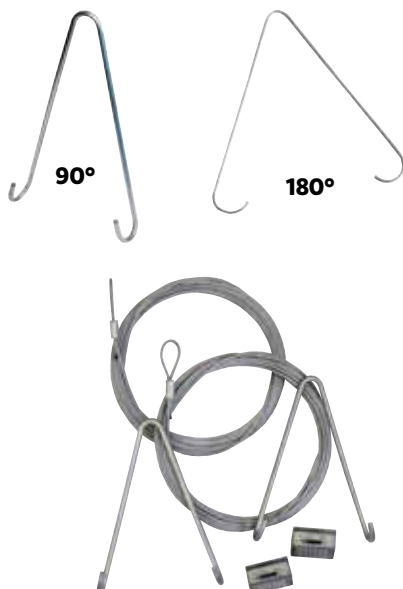

## V Clip Kit

The V Clip is used for suspension of lighting. It can be packaged with single loop or double loop pre-cut cable in kits for linear lighting. The V Clip can also be purchased in bulk quantities with our starter kits.

ITEM #	CODE	DESCRIPTION	QTY
<b>V CLIP</b>			
RO30100	VHC90	90 Degree V-hook	100
RO30096	VHC	180 Degree V Hanger Clip	100
<b>V CLIP KITS</b>			
RO30276	WC21518YLVK	(1) WC2 15 ft w/18 in Y looped cable, (2) V-Clips & (1) CL6 - Kit	50
RO30110	WC20590LVK	(2) WC2 5 ft looped cable & (2) 90° V-Clips & (2) CL6 - Kit	50
RO30111	WC21090LVK	(2) WC2 10 ft looped cable & (2) 90° V-Clips & (2) CL6 - Kit	50
RO30032	WC21590LVK	(2) WC2 15 ft looped cable & (2) 90° V-Clips & (2) CL6 - Kit	50
RO30112	WC22590LVK	(2) WC2 25 ft looped cable & (2) 90° V-Clips & (2) CL6 - Kit	50
RO30327	WC210180LVK	(2) WC2 10 ft looped cable & (2) 180° V-Clips & (2) CL6 - Kit	50

**Flat Panel Kit**

Flat Panel Kits come with a 10 ft looped WC3 cable, a 26" double sided eyelet cable, and a side exit Kwik Grip Cable Lock, featuring a 12 lb. weight limit with a 5:1 safety factor ratio. The eyelets are constructed of 304 Stainless Steel and conveniently designed to fit the grid clip on most Flat Panel LED Light Fixtures.

ITEM #	CODE	DESCRIPTION	QTY
RO30123	FPGK2605	(2) WC2 x 5 ft Loop Cable, (2) Side Exit Gripper, (2) Dual Eyelet 26" wire	50
RO30124	FPGK2610	(2) WC2 x 10 ft Loop Cable, (2) Side Exit Gripper, (2) Dual Eyelet 26" wire	50
RO30125	FPGK2615	(2) WC2 x 15 ft Loop Cable, (2) Side Exit Gripper, (2) Dual Eyelet 26" wire	50
RO31018	FPGK2620	(2) WC2 x 20 ft Loop Cable, (2) Side Exit Gripper, (2) Dual Eyelet 26" wire	25
RO31026	FPGK2625	(2) WC2 x 25 ft Loop Cable, (2) Side Exit Gripper, (2) Dual Eyelet 26" wire	25

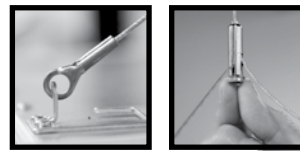
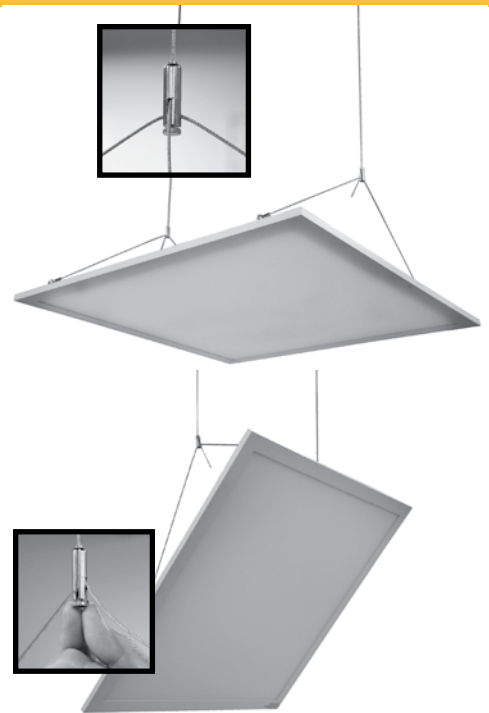

**Track Hanger Kit**

The Track Hanger is a light hanger which includes Looped Cable, Side Exit Kwik-Grip, and two different length 1/4"-20 mounting bolts. 50 lb. working load limit.

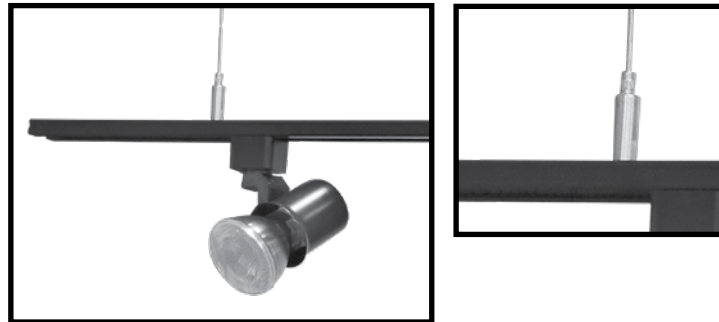

ITEM #	CODE	DESCRIPTION	SAFE WORKING LOAD*	QTY
RO30190	RWC2-20LCSEGK	WC2 x 20 ft Looped Cable w/Side Exit Kwik-Grip & 2 Locking Screws	50lb (23 kg)	100



**Kwik-Barrel Assemblies**

ITEM #	CODE	DESCRIPTION	QTY
RO31001	KBA14205	1/4" x 20 Barrel with WC2x5 ft Cable	100
RO31002	KBA14210	1/4" x 20 Barrel with WC2x10 ft Cable	100
RO31003	KBA14215	1/4" x 20 Barrel with WC2x15 ft Cable	100
RO31005	KBA14225	1/4" x 20 Barrel with WC2x25 ft Cable	50
RO31008	KBA38310	3/8" x 16 Barrel with WC3x10 ft Cable	100

# DYNA-TITE CABLE, END FITTINGS & KITS

## Kwik Grips

Kwik-Grips are accessory hardware used for hanging architectural lighting with cable. Included in this group are various cable couplers as well as cable grippers. Kwik-Grips are sold 100 per box.

<p>Item #: RO30209 Code: BEG38IPSW Bottom Exit Gripper w/Safety Nut RWC3 Cable* 3/8 in - 20 Male</p>	<p>Item #: RO30210 Code: BEG1420 Bottom Exit Gripper w/Safety Nut WC2 Cable* 1/4 in - 20 Male</p>	<p>Item #: RO30211 Code: SEG1420 Side Exit Gripper w/Safety Nut WC2 Cable* 1/4 in - 20 Female</p> <p>*30208 - Available with 8/32in bottom screw</p>
<p>Item #: RO30212 Code: BEG14IP Bottom Exit Gripper w/Safety Nut WC2 &amp; WC3* Cable 1/8 in - 20 IP Male</p>	<p>Item #: RO30213 Code: BEG38IP Bottom Exit Gripper w/Safety Nut WC2 &amp; WC3 Cable* 3/8 in - 20 IP Male</p>	<p>Item #: RO30214 Code: SEGSCC Side Exit Gripper w/Safety Nut WC2 Cable* Slotted for Cross Cable</p>
<p>Item #: RO30215 Code: 1CC1420 Threaded 1/4 in - 20 Female 1-Piece Cable Coupler</p>	<p>Item #: RO30216 Code: 2CC1420 Threaded 1/4 in - 20 Male 2-Piece Cable Coupler</p>	<p>Item #: RO30218 Code: 1CCS14IP Threaded 1/4 in - 20 IP Female Slotted Cable Coupler</p>

\*Grippers with the WC2 cable version is 75 lbs and the WC3 is 150 lbs at 4:1

ITEM #	CODE	DESCRIPTION	QTY	ITEM #	CODE	DESCRIPTION	QTY
RO30209	BEG38IPSW	3/8-20 Male Bottom Exit Gripper	100	RO30214	SEGSCC	Side Exit Gripper w/ Safety Nut & Allen Screw WC2 Cable Slotted for Cross cable	100
RO30210	BEG1420	Bottom Exit Gripper w/ Safety Nut WC2 Cable 1/4-20 IP Male	100	RO30215	1CC1420	Threaded 1/4-20 Female 1-Piece Cable Coupler	100
RO30211	SEG1420	Side Exit Gripper w/ Safety Nut WC2 Cable 1/4-20 Female	100	RO30216	2CC1420	Threaded 1/4-20 Male 2-Piece Cable Coupler	100
RO30212	BEG14IP	Bottom Exit Gripper w/ Safety Nut WC2 & WC3 Cable 1/8-20 IP Male	100	RO30218	1CCS14IP	Threaded 1/4-20 IP Female Slotted Cable Coupler	100
RO30213	BEG38IP	Bottom Exit Gripper w/ Safety Nut WC2 & WC3 Cable 3/8-20 IP Male	100				

# DYNA-TITE CABLE, END FITTINGS & KITS

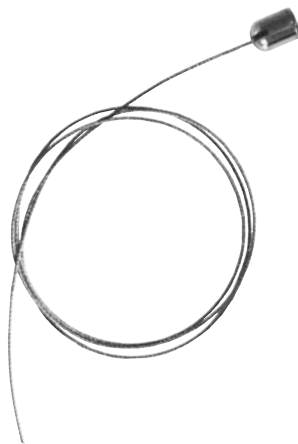

## Kwik-Grips Cables

ITEM #	CODE	DESCRIPTION	QTY
RO30310	RWC2-50DS	WC2 Cable with #2 Stop/50in Length	100
RO30311	RWC2-120DS	WC2 Cable with #2 Stop/120in Length	100
RO30312	RWC2-250DS	WC2 Cable with #2 Stop/250in Length	50
RO30315	RWC2-08CCTS	WC2 Galvanized Cable Assembly w/ Fuse Cut End & #2 Diecast Stop 50" Length	100
RO30316	RWC2-12CCTS	WC2 Galvanized Cross cables w/ 1/4"-20 Threaded Stud Captive 12" Length	100
RO30317	RWC2-18CCTS	WC2 Galvanized Cross cables w/ 1/4"-20 Threaded Stud Captive 18" Length	100
RO30318	RWC2-24CCTS	WC2 Galvanized Cross cables w/ 1/4"-20 Threaded Stud Captive 24" Length	100

## Safety Cables

Safety Cables are commonly used for lighting in the oil, gas, mining and entertainment industries.

ITEM #	CODE	DESCRIPTION	QTY
RO30036	RDCL4SS	4ft Stainless Steel Double Loop Harness w/Locking Snap Hook	20
RO30037	RDCL5SS	5 ft Stainless Steel Single Drop Safety Cable	50



## Cat Loc

Used in conjunction with the CL23L-WC6, the Cat Loc can be used to suspend lights and signs from a horizontal cable. This aesthetically pleasing system is fast and easy and will help you install lighting where no anchor points are available. Once the Cat Loc is installed on the horizontal cable you are able to move it and lock it in place at the ground level by twisting the cable. This saves time on the work site by not having to go back up to the unit to move and lock in place. The Cat Loc has a working load of 75 lbs (34 kgs) and is sold with the cable already attached to simplify installation.

### Features:

- ▶ A work load limit of 75 lbs (34 kgs)
- ▶ Sold with the cable pre-attached

ITEM #	CODE	DESCRIPTION	BOX QTY	QTY
RO30188	RCL4M	Cat Loc w/10 ft WC2 Cable	10	100
RO30189	RCL1M	Cat Loc w/5 ft WC2 Cable	10	100



CL23L-WC6

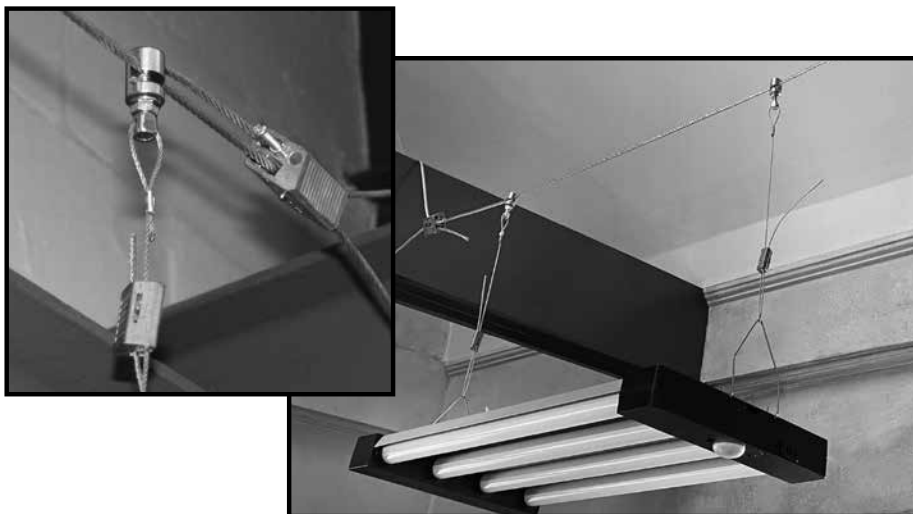

# DYNA-TITE EQUIPMENT SUSPENSION STRUT KITS

## Strut Kits

The Strut Lock Assembly offers a rapid, lockable solution for HVAC and cable management, ideal for suspending various items such as ducts, cable trays, and unit heaters. With pre-fitting capabilities on the ground, it minimizes work at heights, while a threaded release cylinder allows for quick height adjustments, saving time.

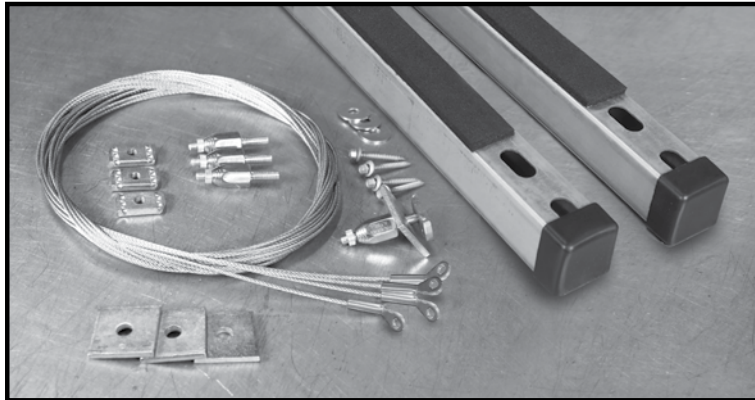

Scan for video



### Benefits:

- ▶ Saves installation time
- ▶ Easy adjustment
- ▶ Reduces inventory
- ▶ Job costing made easy

### Features:

- ▶ Includes everything needed to suspend air handlers and equipment in attics, garages, ceilings, and basements.
- ▶ No cutting required.
- ▶ Supports up to 600 lbs.
- ▶ Accommodates units up to 32" in width.
- ▶ Cable and lock flexibility allow for easy leveling of equipment.
- ▶ Vibration padding reduces noise level.



ITEM #	CODE	LENGTH	DESCRIPTION	UOM
32058	TSS3310SL4DW-SK	10 ft	36 in Strut Kit w/Strut Lock, Threaded Stud, Dual Hanger, Struts	1 Kit
32059	TS3315SL4DW-SK	15 ft	36 in Strut Kit w/Strut Lock, Threaded Stud, Dual Hanger, Struts	1 Kit
32054	E44310SL4WS-SK	10 ft	36 in Strut Kit w/Strut Lock, Eyelet Cable, Wood Screw, Struts	1 Kit
32055	E44315SL4WS-SK	15 ft	36 in Strut Kit w/Strut Lock, Eyelet Cable, Wood Screw, Struts	1 Kit

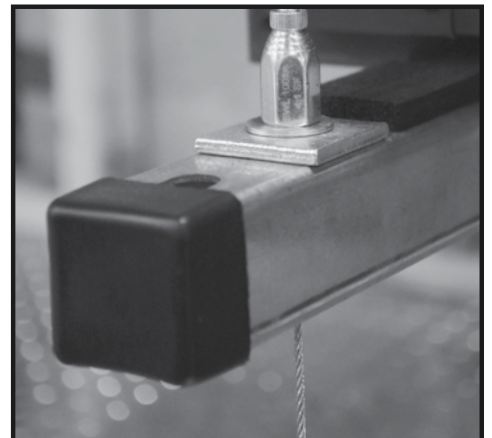

# DYNA-TITE EQUIPMENT SUSPENSION 4-PACK KITS

Introducing Duro-Dyne Dyna-Tite Equipment Suspension Kits! All the components needed to suspend equipment packaged together in one kit. Pick out the lock, the cable assembly and attachment accessory in the quantity needed to do the installation faster and with less waste reducing skus and inventory

- ▶ Choose your end fitting: loop cable, threaded stud, toggle, drive pin, wedge, snap hook or eyelet.
- ▶ Choose your cable length: 5, 10, 15, 20 or 25 feet.
- ▶ Choose your lock style: standard CL, Strut Lock, CL90 or KV.
- ▶ Choose a hanger accessory.
- ▶ Dyna-Tite then packages up the items you request, with common configurations already in stock.

## EXAMPLE

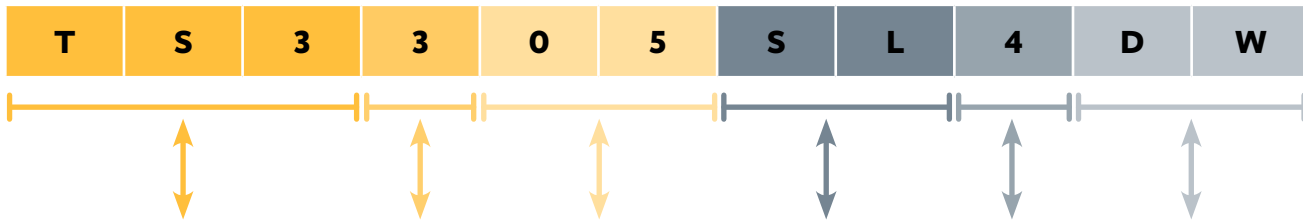

ENDFITTING		CABLE SIZE		CABLE LENGTH		LOCK TYPE		QTY PER BAG	ANCHOR	
LCA	Looped Cable Assembly	2	WC2	05	5 feet	CL	CL Series	4	DS	Dual Hanger Steel
TS4	Threaded Stud 1/4"	3	WC3	10	10 feet	C9	CL90**	2	DW	Dual Hanger Wood
TS3	Threaded Stud 3/8"	4	WC4	15	15 feet	KV	KV Bracket**	1	PP	3" Tech Screw
DPA	Drive Pin Assembly	6	WC6	20	20 feet	SL	Strut Lock***		TS	Tech Screw
TGA	Toggle Assembly			25	25 feet				WS	2" Wood Screw
TGY	Y Toggle Assembly								00	No Accessory
SHA	Snap Hook Assembly									
SHY	Y Snap Hook Assembly									
WAA	Wedge Anchor Assembly									
E94	Eyelet 90° 1/4"									
E93	Eyelet 90° Degree 3/8"									
ES3	Eyelet Straight 3/8"									
ES4	Eyelet Straight 1/4"									
E44	Eyelet 45° 1/4"									
E43	Eyelet 45° 3/8"									



\*CONTACT DURODYNE CUSTOMER SERVICE AND TO PLACE ORDER  
 \*\*FOR WC2 AND WC3 CABLE ONLY  
 \*\*\*FOR WC3 AND WC4 CABLE ONLY

## Accessories

Dual Hangers are both end-tapped and cross-tapped for both in-line mounting and side-mounting of threaded rod and more.

- ▶ Dual Hangers available for both wood and steel
- ▶ Hex Head wood screws with washer for easy installation



ITEM #	DESCRIPTION
DS	DYNA-TITE - Dual Hanger - Steel
DW	DYNA-TITE - Dual Hanger - Wood
WS	DYNA-TITE - 2" Wood Screw
TS	DYNA-TITE - Tech Screw

## Cable Locks

The quick and easy way to lock cables at any length

ITEM #	DESCRIPTION	CABLE SIZE
CL	CL Series	WC2, WC3, WC4, WC6
C9	CL90 Lock	WC2, WC3
KV	KV Lock Assembly	WC2, WC3
SL	Strut Lock Assembly	WC3, WC4

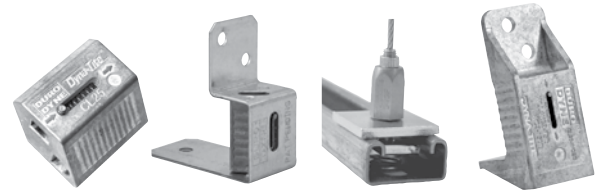

## End Fixings

- ▶ Pre-attached to cables
- ▶ Eyelets available in straight, 45° and 90°
- ▶ Toggles and Snap Hooks available in Y-shape and single-strand

ITEM #	DESCRIPTION
LCA	DYNA-TITE - Looped Cable Assembly
TS3	DYNA-TITE - Threaded Dyna-Stud 3/8"
TS4	DYNA-TITE - Threaded Dyna-Stud 1/4"
DPA	DYNA-TITE - Drive Pin Assembly
TGA	DYNA-TITE - Toggle Assembly
TGY	DYNA-TITE - Y Toggle Assembly
SHA	DYNA-TITE - Snap Hook Assembly
SHY	DYNA-TITE - Y Snap Hook Assembly
WAA	DYNA-TITE - Wedge Anchor Assembly
E94	DYNA-TITE - Eyelet 90° 1/4"
E93	DYNA-TITE - Eyelet 90° 3/8"
ES3	DYNA-TITE - Eyelet Straight 3/8"
ES4	DYNA-TITE - Eyelet Straight 1/4"
E44	DYNA-TITE - Eyelet 45° 1/4"
E43	DYNA-TITE - Eyelet 45° 3/8"

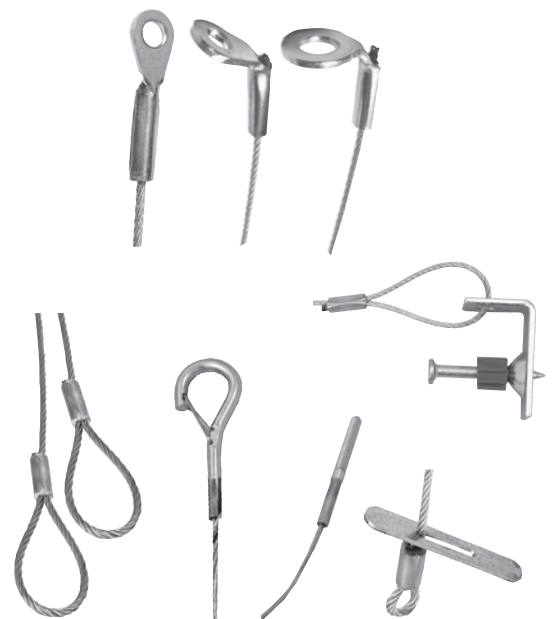

# DYNA-TITE EQUIPMENT SUSPENSION 4-PACK KITS

## Dyna-Tite Ready-to-Ship 4-Pack Kits

ITEM #	CODE	DESCRIPTION	SAFE WORKING LOAD**	END FITTING	CABLE SIZE	CABLE LENGTH	LOCK TYPE	QTY PER BAG	ACCESSORY
32029	TS3305CL4DW	3/8" Threaded Stud WC3 Equipment Suspension Kit	25 - 150 lbs (12 - 68 kg)	3/8" Threaded Stud	WC3	5 feet	CL Series	4	Dual Hanger Wood
32030	TS3310CL4DW	3/8" Threaded Stud WC3 Equipment Suspension Kit	25 - 150 lbs (12 - 68 kg)	3/8" Threaded Stud	WC3	10 feet	CL Series	4	Dual Hanger Wood
32001	TS3305SL4DW	3/8" Threaded Stud WC3 Equipment Suspension Kit	25 - 150 lbs (12 - 68 kg)	3/8" Threaded Stud	WC3	5 feet	Strut Lock	4	Dual Hanger Wood
32002	TS3310SL4DW	3/8" Threaded Stud WC3 Equipment Suspension Kit	25 - 150 lbs (12 - 68 kg)	3/8" Threaded Stud	WC3	10 feet	Strut Lock	4	Dual Hanger Wood
32037	TS3305KV4DW	3/8" Threaded Stud WC3 Equipment Suspension Kit	25 - 150 lbs (12 - 68 kg)	3/8" Threaded Stud	WC3	5 feet	KV	4	Dual Hanger Wood
32038	TS3310KV4DW	3/8" Threaded Stud WC3 Equipment Suspension Kit	25 - 150 lbs (12 - 68 kg)	3/8" Threaded Stud	WC3	10 feet	KV	4	Dual Hanger Wood
32041	E44305CL4WS	45 Degree 1/4" Eyelet WC3 Equipment Suspension Kit	25 - 150 lbs (12 - 68 kg)	45 Degree 1/4" Eyelet	WC3	5 feet	CL Series	4	2" Wood Screw
32042	E44310CL4WS	45 Degree 1/4" Eyelet WC3 Equipment Suspension Kit	25 - 150 lbs (12 - 68 kg)	45 Degree 1/4" Eyelet	WC3	10 feet	CL Series	4	2" Wood Screw
32049	E44305SL4WS	45 Degree 1/4" Eyelet WC3 Equipment Suspension Kit	25 - 150 lbs (12 - 68 kg)	45 Degree 1/4" Eyelet	WC3	5 feet	Strut Lock	4	2" Wood Screw
32050	E44310SL4WS	45 Degree 1/4" Eyelet WC3 Equipment Suspension Kit	25 - 150 lbs (12 - 68 kg)	45 Degree 1/4" Eyelet	WC3	10 feet	Strut Lock	4	2" Wood Screw
32045	E44305KV4WS	45 Degree 1/4" Eyelet WC3 Equipment Suspension Kit	25 - 150 lbs (12 - 68 kg)	45 Degree 1/4" Eyelet	WC3	5 feet	KV	4	2" Wood Screw
32046	E44310KV4WS	45 Degree 1/4" Eyelet WC3 Equipment Suspension Kit	25 - 150 lbs (12 - 68 kg)	45 Degree 1/4" Eyelet	WC3	10 feet	KV	4	2" Wood Screw
•	E94305CL4WS	90 Degree 1/4" Eyelet WC3 Equipment Suspension Kit	25 - 150 lbs (12 - 68 kg)	90 Degree 1/4" Eyelet	WC3	5 feet	CL Series	4	2" Wood Screw
•	E94310CL4WS	90 Degree 1/4" Eyelet WC3 Equipment Suspension Kit	25 - 150 lbs (12 - 68 kg)	90 Degree 1/4" Eyelet	WC3	10 feet	CL Series	4	2" Wood Screw
•	E94305SL4WS	90 Degree 1/4" Eyelet WC3 Equipment Suspension Kit	25 - 150 lbs (12 - 68 kg)	90 Degree 1/4" Eyelet	WC3	5 feet	Strut Lock	4	2" Wood Screw
•	E94310SL4WS	90 Degree 1/4" Eyelet WC3 Equipment Suspension Kit	25 - 150 lbs (12 - 68 kg)	90 Degree 1/4" Eyelet	WC3	10 feet	Strut Lock	4	2" Wood Screw
•	E94305KV4WS	90 Degree 1/4" Eyelet WC3 Equipment Suspension Kit	25 - 150 lbs (12 - 68 kg)	90 Degree 1/4" Eyelet	WC3	5 feet	KV	4	2" Wood Screw
•	E94310KV4WS	90 Degree 1/4" Eyelet WC3 Equipment Suspension Kit	25 - 150 lbs (12 - 68 kg)	90 Degree 1/4" Eyelet	WC3	10 feet	KV	4	2" Wood Screw
•	ES4305CL4WS	Straight 1/4" Eyelet WC3 Equipment Suspension Kit	25 - 150 lbs (12 - 68 kg)	Straight 1/4" Eyelet	WC3	5 feet	CL Series	4	2" Wood Screw
•	ES4310CL4WS	Straight 1/4" Eyelet WC3 Equipment Suspension Kit	25 - 150 lbs (12 - 68 kg)	Straight 1/4" Eyelet	WC3	10 feet	CL Series	4	2" Wood Screw
•	ES4305SL4WS	Straight 1/4" Eyelet WC3 Equipment Suspension Kit	25 - 150 lbs (12 - 68 kg)	Straight 1/4" Eyelet	WC3	5 feet	Strut Lock	4	2" Wood Screw
•	ES4310SL4WS	Straight 1/4" Eyelet WC3 Equipment Suspension Kit	25 - 150 lbs (12 - 68 kg)	Straight 1/4" Eyelet	WC3	10 feet	Strut Lock	4	2" Wood Screw
•	ES4305KV4WS	Straight 1/4" Eyelet WC3 Equipment Suspension Kit	25 - 150 lbs (12 - 68 kg)	Straight 1/4" Eyelet	WC3	5 feet	KV	4	2" Wood Screw
•	ES4310KV4WS	Straight 1/4" Eyelet WC3 Equipment Suspension Kit	25 - 150 lbs (12 - 68 kg)	Straight 1/4" Eyelet	WC3	10 feet	KV	4	2" Wood Screw
32033	TS3405CL4DW	3/8" Threaded Stud WC4 Equipment Suspension Kit	25 - 250 lbs (12 - 114 kg)	3/8" Threaded Stud	WC4	5 feet	CL Series	4	Dual Hanger Wood
32034	TS3410CL4DW	3/8" Threaded Stud WC4 Equipment Suspension Kit	25 - 250 lbs (12 - 114 kg)	3/8" Threaded Stud	WC4	10 feet	CL Series	4	Dual Hanger Wood
32005	TS3405SL4DW	3/8" Threaded Stud WC4 Equipment Suspension Kit	25 - 250 lbs (12 - 114 kg)	3/8" Threaded Stud	WC4	5 feet	Strut Lock	4	Dual Hanger Wood
32006	TS3410SL4DW	3/8" Threaded Stud WC4 Equipment Suspension Kit	25 - 250 lbs (12 - 114 kg)	3/8" Threaded Stud	WC4	10 feet	Strut Lock	4	Dual Hanger Wood

\*Safe Working Loads are based on a 5:1 Safety Factor.

+Hanging at angles will reduce the Safe Working Loads. Please see our 'Effects of Hanging at Angles' table on page 24.

# DYNA-TITE PROJECT COMPLETERS

## Dyna-Chain™

Dyna-Chain is a Zinc Plated Double Loop 2/0 chain. This is a steel constructed economical utility chain. It has a 255 lb working load limit, ideal for hanging lightweight equipment and lighting. Often used by contractors as a theft deterrent for locking ladders and job boxes, the applications are virtually endless! It is sold in a convenient bucket to make use on the job site easier, with a scored top for easing opening and built in loop to keep track of the end of the chain.



ITEM #	CODE	DESCRIPTION	QTY
30027	ZPC2/0-300	Dyna-Chain Zinc Plated Double Loop 2/0	300 ft/pail

- ▶ Sold 300 ft per pail
- ▶ Cut Dyna-Chain with Duro Dyne Cable Cutter
- ▶ Applications: Industrial, Mechanical, Residential, Commercial, and Electrical

## Eye Bolt & Nut

A simple way to provide an anchor point is by using an eye bolt and nut. The eye bolt has a 3/4 in inside diameter ring to make wire rope attachment easy. Weight limit of 400 lbs.



ITEM #	CODE	DESCRIPTION	QTY
30220	DDG3W	Eye Bolt & Nut (3/8 in-16 x 2-1/2 in)	100

## Rapit® Duct Support Hanger

The Rapit Drop-In Deck Hanger is designed for installation in concrete-filled metal deck assemblies. RDI Deck Hangers are installed before pouring the concrete, to reduce installation costs and increase strength values. Once installed, the insert hangs below the deck surface for easy installation of threaded rod or Dyna-Studs.

ITEM #	CODE	DESCRIPTION	QTY
30339	RDI38	3/8 in Rapit® Drop-In Deck Hanger	50



Bottom View

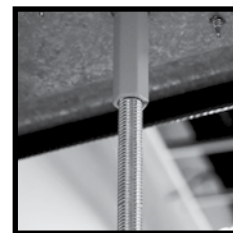

3/8" Threaded Rod



3/8" Dyna-Stud

Top View (Before Concrete pour)



## Cable Cutters

When cutting wire cable it is important to use a recognized wire cable cutter such as the Duro Dyne cutters detailed here. This will ensure that the form of the rope is maintained prior to insertion in the Dyna-Tite Cable Lock.

ITEM #	CODE	DESCRIPTION	QTY
818263	DTWRCL	Cable Cutter	1
30344	DTRWC14	Heavy Duty Wire Rope Cutter up to WC8	1

**DTWRCL**



### DTWRCL Features:

- ▶ Spring Loaded for ease of use
- ▶ For WC2, WC3, WC4 and WC6 Wire Rope and Dyna-Chain
- ▶ Will cut soft chain
- ▶ Hardened Steel Blades For Durability
- ▶ Vinyl Coated Handles For Comfortable, Non-Slip Grip

### DTRWC14 Features:

- ▶ For WC6 and WC8 Wire Rope and Dyna-Chain
- ▶ Hardened Steel Blades For Durability
- ▶ Vinyl Coated Handles For Comfortable, Non-Slip Grip

**DTRWC14**



## Spiral Buckle

The zinc plated 14 gauge Spiral Buckle is designed to suspend round and oval ductwork from ceiling joists or beams with the use of threaded rod up to 3/8 in diameter. Simply place 1 in hanging strap in one side of the buckle then around the material and into the other side of the buckle. When the strap is correctly inserted through the slots, the strap is locked into the buckle by the weight of the duct.

ITEM #	CODE	DESCRIPTION	QTY
30340	DSB1	Dyna-Tite Spiral Buckle	50/box

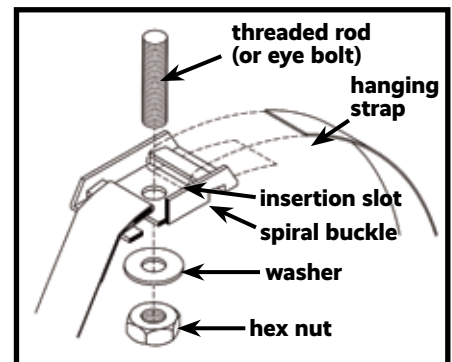
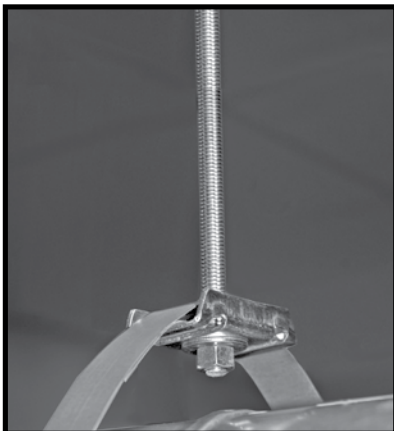

### Strut Hanger Clip

The Strut Hanger Clip is suitable for slotted channels, lighting, trunking, luminaires, and cable tray. Simple to install. Push it into the strut, ensuring that the short leg is at the cut end of the channel. Working load limit: 40 lbs

ITEM #	CODE	DESCRIPTION	QTY
R030299	SHC	Strut Hanger Clip	100

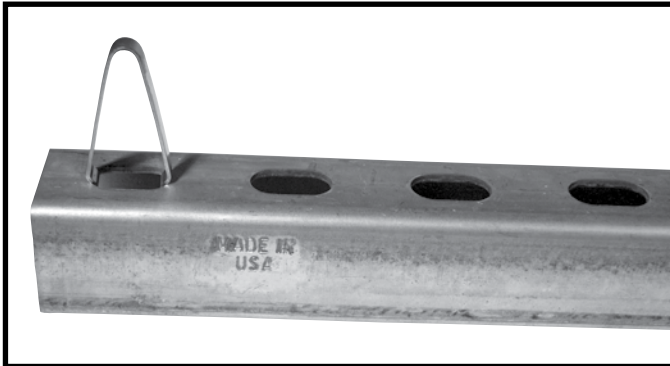

### Dual Hangers

When preparing to suspend HVAC equipment, ductwork or accessories, threaded anchor points are often required. Dual Hangers from Duro Dyne are one-piece anchors that feature heads that are both end-tapped and crosstapped to permit both in-line mounting and side-mounting of threaded rod systems, eye rings and more. There are two variations of Dual Hangers; one for penetrating and threading into steel and one for wood.



- ▶ No pilot hole is needed
- ▶ All fasteners are zinc plated for corrosion resistance
- ▶ Chucks sold separately for easy installation



**Steel**



**Wood**

ITEM #	CODE	DESCRIPTION	QTY
31390	DHW8-25	Dual Head Vertical and Horizontal Wood Fasteners	25/Ctn.
31391	VHW38-25	Dual Head Vertical and Horizontal Steel Fasteners	25/Ctn.

# WARNINGS

As a matter of sound engineering practice, the Dyna-Tite assembly must be located no closer than 12 in to the suspension point (as illustrated on page 4). In the case of round duct, where the wire rope encircles the duct, the Dyna-Tite must be located the distance of one diameter from the duct wall. Adherence to these minimum clearances will distribute the load the most efficiently among all duct hanging components.

**ALWAYS FOLLOW THE INSTALLATION INSTRUCTIONS BELOW.**

There are many variables to be considered when installing Dyna-Tite cables and affixing them to upper attachments. The contractor is solely responsible for selecting the appropriate Dyna-Tite product for the specific circumstances of each installation. The contractor must select the appropriate Dyna-Tite product that meets the approval of the mechanical engineer and complies with all applicable codes and job specifications.

## FOR STATIC LOAD APPLICATIONS ONLY

- **FOR STATIC LOAD APPLICATIONS ONLY**
- **ALWAYS** Confirm engagement of Cable Lock on wire before applying the load: By pushing the adjustment pin in the opposite direction of the arrows on the Cable Lock and then pulling the cable also in the opposite direction of the arrows on the Cable Lock.
- **PULL ADJUSTMENT PIN BACK AND PASS WIRE ROPE THROUGH DYNA-TITE Cable Lock:** Failure to pull adjustment pin first may cause damage to serrated teeth and reduce holding capacity.
- **To ENSURE HANGING SYSTEM INTEGRITY AND SAFETY:** Use only Duro Dyne wire rope.
- **WORKING LOAD LIMIT (WLL) MUST FALL WITHIN THE STATED WORKING LOAD RANGE OF THE Cable Lock:** Each product is load rated and incorporates a minimum safety factor of 4:1. This WLL takes into account the specification criteria of the Dyna-Tite Cable Lock and the wire rope.
- **Do not use on coated wire rope:** It is important to maintain the metal to metal contact between the locking pawls in the Dyna-Tite and the wire rope.
- **SPRAY PAINTING:** of the Dyna-Tite Cable Hanging System after installation is acceptable, at the installing contractor's discretion, if the installing contractor physically confirms engagement of each Cable Lock on the cable prior to and after painting, and in strict accordance with the Dyna-Tite Installation Instructions. Brush painting is not acceptable. Do not paint Cable or Cable Lock prior to installation. Do not reposition Cable Lock after painting.
- **Do not apply lubricant:** to any part of the assembly as this will alter the surface nature of the wire rope and attract dirt and debris.
- **Do not use for lifting:** (Under Hook slings) This product is designed for static load applications only.
- **Keep the product clean and free from dirt:** Any dirt should be removed from the product prior to assembly.
- **Inspect periodically:** Upon inspection, discard and replace if worn, distorted, or damaged.
- **Remove damaged wire ends:** Using a designated pair of wire rope cutters prior to inserting into the Dyna-Tite Cable Lock.
- **When installing Duro Dyne Dyna-Tite cable attachments:** to buildings or equipment careful consideration must be made to the attachment method and the material being attached to. It is the responsibility of the installer for the proper selection, installation and appropriateness of the attachment to the job specifications and any codes. Duro Dyne can give general guidance, but any questions regarding this should ultimately be directed to the project engineer of the job.
- **For Dry Locations ONLY**
- **Do not use in chlorinated atmospheres** such as pools and natatorium
- **Gymnasium installs Must be using Locking Cable Locks only**

# EFFECTS OF HANGING AT ANGLES

SIZE CABLE	VERTICAL	15 DEGREES	30 DEGREES	45 DEGREES	60 DEGREES
WC8 Wire Rope	1,100 LBS	1,060 lbs	950 lbs	775 lbs	550 lbs
WC6 Wire Rope	640 lbs	625 lbs	559 lbs	455 lbs	325 lbs
WC4 Wire Rope	250 lbs	240 lbs	215 lbs	175 lbs	125 lbs
WC3 Wire Rope	150 lbs	144 lbs	129 lbs	105 lbs	75 lbs
WC2 Wire Rope	75 lbs	72 lbs	64.5 lbs	52.5 lbs	37.5 lbs
Load	100%	96%	86%	70%	50%

# TESTING

All Dyna-Tites have been independently tested to five times their allowable working load by one or more of the following independent laboratories:

RADCO Inc, Long Beach CA  
SMACNA Testing and Research Institute  
New York Testing Laboratories

WC1, WC2, WC3, WC4, WC6 Wire Rope & WC8 Wire Rope have been tested to meet UL 1598.



New York Product  
Testing & Services Inc.



# APPLICATIONS

Dyna-Tite Cable Locks and wire rope can be used for suspension in a variety of ways to accommodate most mechanical and HVAC construction applications.

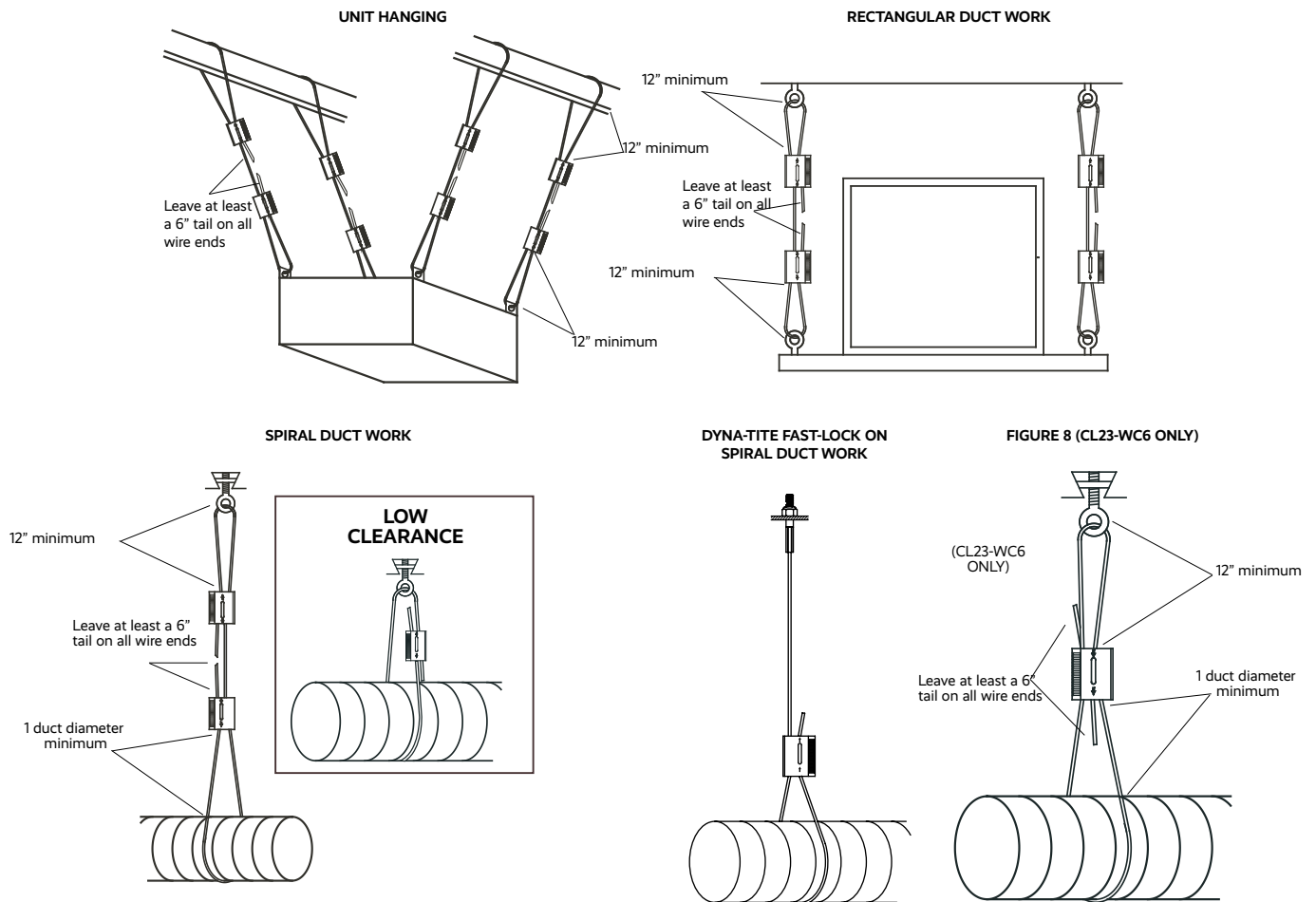

# INSTALLATION INSTRUCTIONS



Scan for more information & instructions

## STANDARD ASSEMBLY

Pull the release pin back and thread the wire rope into one locking channel in the Cable Lock. Failure to pull adjustment pin first may cause damage to serrated teeth and reduce holding capacity.

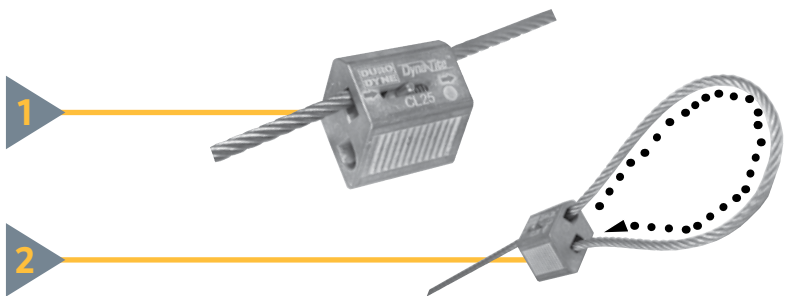

Pass the wire rope "tail" through (or around) the anchor point (Eyehook, Beam, or Purlin).



Pull the second release pin back and push the wire rope tail into the second locking channel in the Cable Lock. Failure to pull adjustment pin first may cause damage to serrated teeth and reduce holding capacity.



Push through at least 6" of the wire rope. Prior to the load being applied, the wire rope can be adjusted in either direction by sliding the release pin and moving the wire.

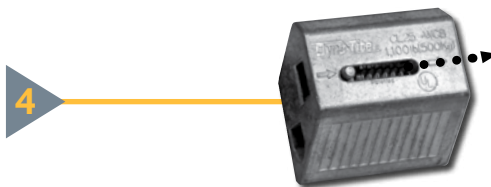

## Adjusting The Cable Lock

With the load off the wire rope and the Cable Lock, push the release pin in the direction of the arrow on the Cable Lock. This will release the locking pawl and allow the wire rope to be moved freely in either direction. (After a load has been applied it may be necessary to pull the cable slightly to disengage the teeth on the pawl). Be sure the load is fully supported before attempting an adjustment.

**ALWAYS CONFIRM ENGAGEMENT OF CABLE LOCK ON WIRE BEFORE APPLYING THE LOAD BY PUSHING THE ADJUSTMENT PIN IN THE OPPOSITE DIRECTION OF THE ARROWS ON THE CABLE LOCK AND THEN PULLING THE CABLE, ALSO IN THE OPPOSITE DIRECTION OF THE ARROWS ON THE CABLE LOCK.**

## OPTIONAL FIGURE 8 ASSEMBLY (CL23-WC6 ONLY)

Thread the wire rope into the "through hole" in the CL23-WC6.

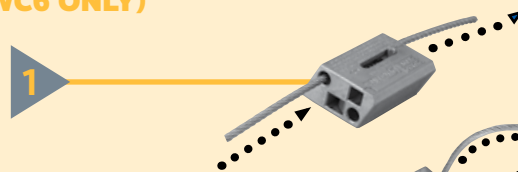

Pass the wire rope "tail" through (or around) the anchor point (Eyehook, Beam, or Purlin).



Pull the release pin back and push the wire rope tail into one locking channel in the CL23-WC6 and pull at least 6" of the wire rope through. Failure to pull adjustment pin first may cause damage to serrated teeth and reduce holding capacity.

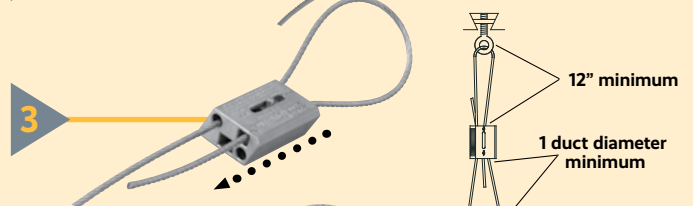

Pass the other wire rope end through (or around) the bracket or fixture on the object to be suspended. Return the wire rope to the CL23-WC6.

Pull the second release pin back and push at least 6" of wire rope through the remaining locking channel. Failure to pull adjustment pin first may cause damage to serrated teeth and reduce holding capacity.

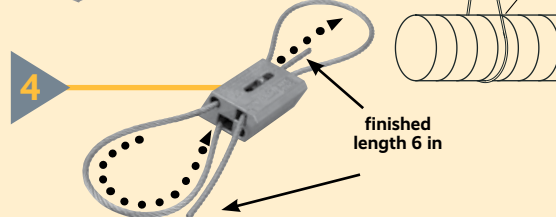

## DYNA-TITE FAST-LOCK ASSEMBLY

1 Thread the wire rope through the “through hole” in the Fast-Lock. Note: The locking channel direction is opposite to the “through hole” direction (path for the wire rope).

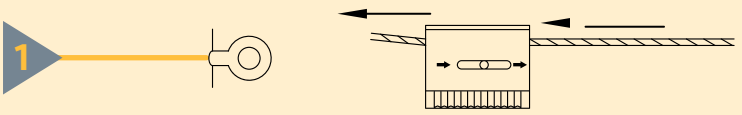

2 Pass the wire rope tail through (or around) the anchor point (eye hook, beam or purlin). Refer to SMACNA Duct Construction Standards for hangers and support selection.

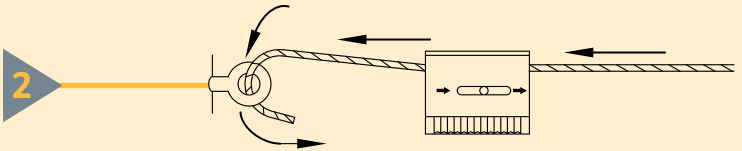

3 Pull adjustment pin back and thread the wire rope into the locking channel in the Fast-Lock. Push through at least 6” of wire rope. Failure to pull adjustment pin first may cause damage to serrated teeth and reduce holding capacity.

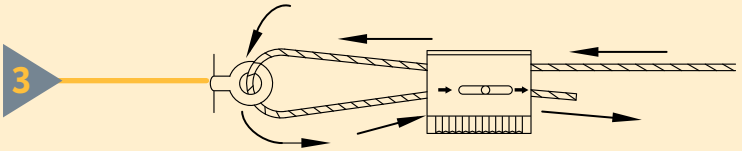

4 Apply load to the wire rope at the entrance to the “through hole” side. ALWAYS confirm engagement of Cable Lock on wire before applying the load by pushing the adjustment pin in the opposite direction of the arrows on the Cable Lock and then pulling the cable, also in the opposite direction of the arrows on the Cable Lock.

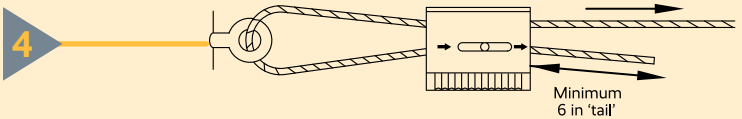

5 To adjust, take the load off and pull the tail slightly to disengage teeth, then release using adjustment pin

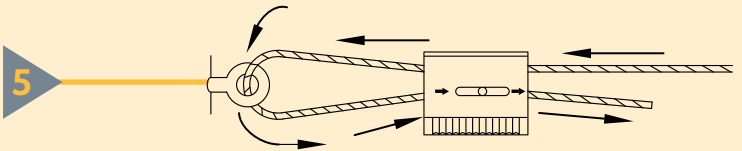

\*Dyna-Tite Fast-Lock for use on round ductwork 24” or less diameter

**ALWAYS CONFIRM ENGAGEMENT OF CABLE LOCK ON WIRE BEFORE APPLYING THE LOAD BY PUSHING THE ADJUSTMENT PIN IN THE OPPOSITE DIRECTION OF THE ARROWS ON THE CABLE LOCK AND THEN PULLING THE CABLE, ALSO IN THE OPPOSITE DIRECTION OF THE ARROWS ON THE CABLE LOCK.**

## STRUT LOCK ASSEMBLY

1 Insert spring strut nut in strut channel and line up with square washer above channel. Position assembly at desired channel location. Insert Strut Lock into washer & spring strut nut and tighten Strut Lock to lock into place.

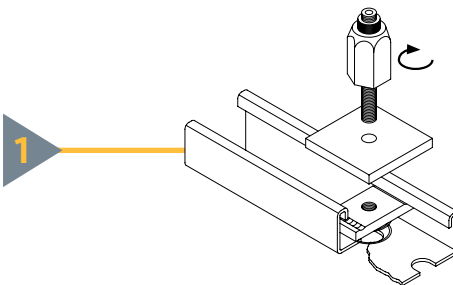

2 Thread the wire rope through the “through hole” in the Fast-Lock. Note: The locking channel direction is opposite to the “through hole” direction (path for the wire rope).

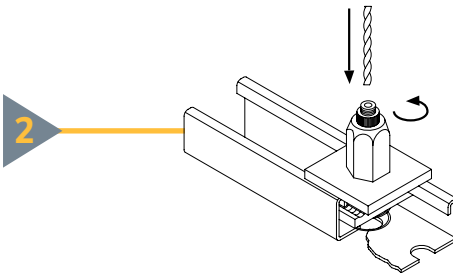

3 Tighten threaded release cylinder to lock wire rope into place.

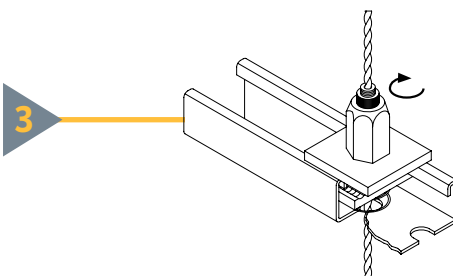



**To order, contact your  
local sales representative.**

[durodyne.com](http://durodyne.com)

TEL  
**631-249-9000**

FAX  
**631-249-8346**

**DYNA-TITE**®