

**Manufacturers of Quality Wire Mesh and Accessories**

**Support Grips • Pulling Grips • Splicing Grips  
Strain Relief Grips • Deluxe Cord Grips • Accessories**





# INDEX

	PAGE
Coming to Grips with Amtec Wire Mesh .....	A
Working Load and Safety Factor Consideration.....	B
Wire Management Products .....	C
Lace & Rod Closing Instructions .....	D
<b>SUPPORT GRIPS</b>	
Standard - Double Eye .....	3
Standard - Single Eye .....	4
Standard - Offset Eye.....	5
Standard - Universal Bale .....	6
Standard - Hook Eye .....	7
Heavy Duty Support .....	8
Light Duty Service Drop .....	9
Conduit Riser - Single Weave Closed Mesh .....	10
Conduit Riser - Double/Single Weave Split Lace.....	11
Conduit Riser - Single Weave - Split Rod .....	12
Conduit Riser - Adapter Rings - Sizing Chart.....	13
<b>PULLING GRIPS:</b>	
Double Weave: Medium Duty Utility Pulling .....	14
Single Weave: Light Duty & Junior Grips.....	15
Slack Pulling Single/Double Weave Closed Mesh .....	16
Slack Pulling Single/Double Weave Split Lace Closing.....	17
Slack Pulling Single Weave Rod Closing .....	17
<b>SPLICING GRIPS:</b>	
Standard Tube - Single/Double Weave.....	18
<b>HOSE CONTAINMENT GRIPS:</b>	
Support Slings.....	19
Hose Containment .....	20
Hose Containment Technical Data.....	21
<b>STRAIN RELIEF GRIPS:</b>	
Strain Relief Grips NPT & NPS Fittings.....	22
Bus Drop Grips / Safety Springs.....	23
Cord Grips.....	24-31
Cord Grips Technical Data .....	32
Metal Clad Sealing "O" Rings .....	33
Deluxe Cord Grips.....	34-35
Backshell Adapter.....	36-37
"1"-Grips.....	38
Sealtite Grips .....	39
Adapters .....	40
Connector Grips.....	41

---

# COMING TO GRIPS WITH AMTEC WIRE MESH

## DESIGN

---

*From conception through design, prototyping and production manufacturing, the Amtec engineering staff works closely with customer engineering to provide the most cost effective system to do the job.*

## ECONOMICS

---

*Amtec is organized, staffed, outfitted, and strategically located to provide the best return on system dollars in the industry. Whether your requirements are for sophisticated, low volume, or for mass produced commercial product, we make it our business to be competitively priced, efficient and on time.*

## QUALITY CONTROL

---

*Amtec is synonymous with quality. We control quality at all levels of manufacture and assembly. Amtec quality wire mesh and related products are 100% manufactured in the USA.*

## WARRANTY

---

*All cable grips and accessories manufactured by Amtec Corp. are guaranteed to be free from defective material and workmanship. Any product found defective in material or workmanship will be replaced without charge, provided notice is given to Amtec Corp. within thirty days after shipment.*

*Customer Service / Tech Line 1-800-893-8397  
30 Center Parkway  
Plainfield, CT 06374*

*Phone: 860-230-0006  
Fax: 860-230-0008  
Email: [meshgrip@sbcglobal.net](mailto:meshgrip@sbcglobal.net)*

**Made in USA**  
Cage Code 1RX07



---

## **WORKING LOAD AND SAFETY FACTOR CONSIDERATIONS**

*The Grips in the catalog have listed approximate Breaking Strength. The approximate breaking strength of an Amtec grip represents an average calculation based on test factors, which have been determined from data established from actual testing performed in our engineering laboratories. The actual testing is performed with new Grips on metal rods, subject to straight longitudinal tensile loads applied at a uniform rate. Normal manufacturing and test factors can produce a variation + or - 20% in the approximate breaking strength values listed.*

*The broad application of Amtec Grips on a wide variety of objects require that adequate safety factors be used to establish a safe working load. The ratio of the listed approximate breaking strength to the normal working load is the safety factor. As an example, a safety factor of ten (10) would then mean the working load is established by dividing the catalog listed approximate breaking strength by ten (10), or it can be stated that the working load is 1/10 of the catalog listed approximate breaking strength.*

*It is impossible to set a safety factor suitable for all cases as operating conditions are never the same. The load, the speed, the acceleration, the diameter, number of objects gripped, surface of object being gripped, and the attachments used - all of these should be considered, together with the effects of abrasion, corrosion, prior use, or abuse, etc. The user-engineer must consider all the variables of his specific application, as well as possible accident consequences, before selecting the safety factor to be applied. Where the conditions of the application are not well defined or where risk of personnel or property damage is high, a greater safety factor should be utilized.*

*Any warranty as to quality, performance or fitness for use of Grips is always premised on the condition that the published approximate breaking strengths apply only to new, unused grips and that such products are properly stored, handled, used, maintained, and properly inspected from time to time during the period of use.*

*The factory should be consulted for specific application recommendations where approximate breaking strength and holding power are critical.*

# ***AMTEC WIRE MANAGEMENT GRIPS***

*Amtec wire mesh grips are used in a wide variety of cable pulling, strain relieving and weight support applications. Wire mesh grips have traditionally been used in the utility, industrial, mining, construction and OEM markets but find new and interesting applications in the communications, information, military, medical, and aerospace industries.*

*Although the most commonly used types of grip applications are shown and described herein, Amtec, a world leader in providing state-of-the-art solutions, can build a grip for virtually any need. We at Amtec are interested in discussing any special product or application.*

## **HAND TOOLS:**

- RADIO TUBE PULLERS
- SLACK PULLING GRIPS
- PULLING GRIPS
- SLINGS

## **IRRIGATION:**

- DELUXE CORD GRIPS
- CORD GRIPS
- SEALING WASHERS
- SEALTITE GRIPS
- LIGHT DUTY PULLING GRIPS

## **MOTORS:**

- CORD GRIPS
- DELUXE CORD GRIPS
- SEALING WASHERS & LOCKNUTS
- SEALTITE GRIPS
- STRAIN RELIEF GRIPS
- CONNECTOR GRIPS

## **ELECTRICAL:**

- STRAIN RELIEF GRIPS
- BUS DROP GRIPS
- CORD GRIPS
- DELUXE CORD GRIPS
- SUPPORT GRIPS
- SEALTITE GRIPS
- PULLING GRIPS
- CONNECTOR GRIPS
- MS90561 GRIPS

## **AGRICULTURAL:**

- SERVICE DROP GRIPS - SAP HARVESTING
- SUPPORT GRIPS - SAP HARVESTING
- CORD GRIPS
- DELUXE CORD GRIPS

## **HVAC:**

- CORD GRIPS
- DELUXE CORD GRIPS
- SEALTITE GRIPS

## **BUILDING & EQUIPMENT MAINTENANCE:**

- CORD GRIPS
- DELUXE CORD GRIPS
- STRAIN RELIEF GRIPS
- BUS DROP GRIPS
- HOSE CONTAINMENT GRIPS
- SUPPORT GRIPS
- PULLING GRIPS
- CONDUIT GRIPS
- SLACK PULLING GRIPS





## **MEDICAL:**

- FINGER GRIPS
- TOE GRIPS

# AMTEC LACE & ROD

## CLOSING INSTRUCTIONS

- Single weave Grips should be laced with single strand lacing; double weave with double strand.
- Lacing strands should be the same material as the Grip.



	<p style="text-align: center;"><b>1</b></p> <p>Start the lacing at the lead or anchoring end of the Grip. Thread the lacings through the first two loops of the split and pull through until the lacings are centered at this point. Lace as you would your shoe, crossing the lacings before lacing the next two loops.</p> 	<p style="text-align: center;"><b>2</b></p> <p>Don't pull lacing too tight. Leave a space between adjoining loops approximately equal to the width of one diamond of the mesh.</p> 	<p style="text-align: center;"><b>3</b></p> <p>Twist the lacing strands tightly together at the tail end of the Grip.</p> 	<p style="text-align: center;"><b>4</b></p> <p>Wrap the ends of the lacings once or twice tightly around the tail of the Grip, twisting the ends together securely. Excess lace can be cut off.</p> 
--	---	---	---	--

Split Grips, closed with a rod, eliminate the time and guesswork of on-the-job lacing. The stainless steel rod is a precise built-in feature which makes threading easy and fast. The strands of the mesh pass around the rod and match up with the strands from the opposite direction. The rod does not touch the cable at any point and therefore cannot cut the cable. Rod Closing Grips are salvageable; may be removed and reused as many times as desired.



### FAST TO INSTALL

Wrap the Grip around the cable and thread the rod through the preformed loops with a corkscrew motion, using the curved end of the rod to engage the loops. The action required is a steady push and twist simultaneously. The fingers of the left hand are used to bring the loops together just ahead of the hook on the end of the rod. To remove, simply pull the rod out.

<p style="text-align: center;"><b>1</b></p> 	<p style="text-align: center;"><b>2</b></p> 	<p style="text-align: center;"><b>3</b></p> 
---	--	---

**CAUTION: NEVER USE GRIPS TO APPROX. BREAKING STRENGTH. REFER TO PAGE "B" FOR SAFETY AND WORKING LOAD FACTORS.**



# AMTEC SUPPORT GRIPS

Standard, Heavy Duty & Conduit Grips

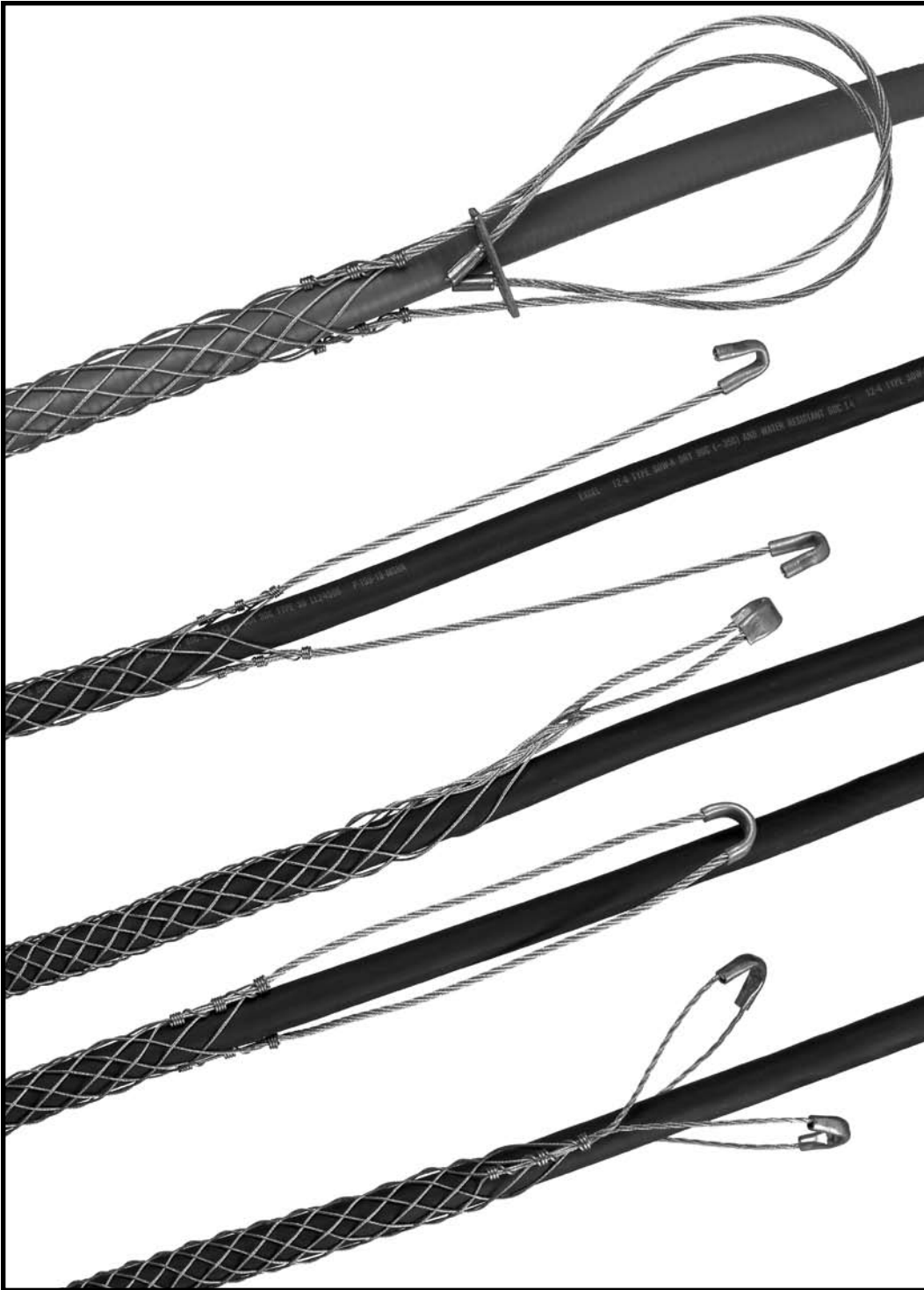

- Designed to hold the weight for electrical cable as it hangs in vertical, sloping or horizontal positions.
- Easily installed and removed using no special skills or tools.
- Permits cable to expand and contract without loss of holding action.
- Instantly relocated or repositioned which saves time and labor.
- Conforms to shape of cable or object being supported.
- Used on any application such as supporting cable, metal rods, hose, and tubing. Specific applications include buildings, poles, excavations, mine shafts, towers, elevators, potheads, terminators, or other structures.

---

# **AMTEC SUPPORT GRIPS**

## **FOR SELECTING THE CORRECT SUPPORT GRIP:**

- Refer to the list below to determine the grip style best suited for your application.
- Determine your cable outside diameter.
- Find the grip size that encompasses your cable diameter.
- Whenever possible, use a closed mesh that assembles over the cable end. If the cable end is not available, use a split mesh.
- Select an eye style that suits your needs.
- Refer to page "b" for work loads and safety factors.

## **GRIP STYLES & APPLICATION:**

- **Closed Mesh:**  
*Permanent support, cable end available.*
- **Split Lace Closing:**  
*Permanent support, cable end unavailable.*
- **Split Rod Closing:**  
*Temporary support, cable end unavailable.*
- **Standard Support Grips:**  
*Support vertical runs to 99 ft. & loads to 600 lbs.*
- **Heavy Duty Support Grips:**  
*Support vertical runs over 100 ft. and loads over 600 lbs.*
- **Service Drop Grips:**  
*Support light duty cable, fiber optic cable & service entrance cable.*
- **Conduit Riser Grips:**  
*Support cable in rigid conduit.*



# AMTEC SUPPORT GRIPS

- Amtec Support Grips are made of stranded tinned bronze wire.
- Stainless steel, medium lengths, and or specials, please consult factory.

## DOUBLE EYE, CLOSED MESH

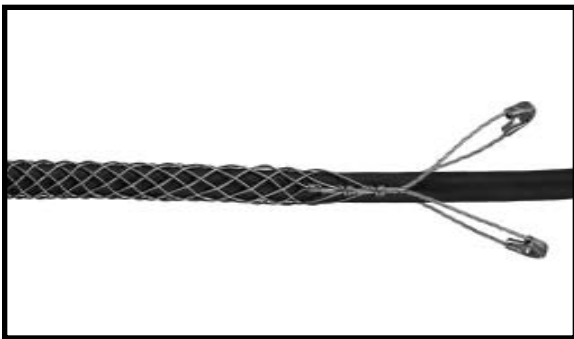

PART NUMBER	DIA.	RA.	DESCRIPTION	APPROX. BREAKING STRENGTH	
				E	M
2201-001	.50-.62		R-050-DE	530 LBS.	4 10
2201-002	.63-.74		R-062-DE	790 LBS.	4 10
2201-003	.75-.99		R-075-DE	1020 LBS.	4 13
2201-004	1.00-1.24		R-100-DE	1610 LBS.	5 14
2201-005	1.25-1.49		R-125-DE	1610 LBS.	5 15
2201-006	1.50-1.74		R-150-DE	1610 LBS.	5 17
2201-007	1.75-1.99		R-175-DE	2150 LBS.	6 19
2201-008	2.00-2.49		R-200-DE	3260 LBS.	6 21
2201-009	2.50-2.99		R-250-DE	3260 LBS.	6 23
2201-010	3.00-3.49		R-300-DE	4900 LBS.	8 25
2201-011	3.50-3.99		R-350-DE	4900 LBS.	8 27

## DOUBLE EYE, LACE CLOSING

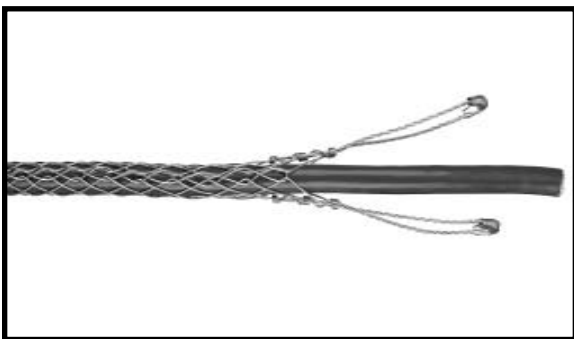

2202-001	.50-.62		RS-050-DE	530 LBS.	4 10
2202-002	.63-.74		RS-062-DE	790 LBS.	4 10
2202-003	.75-.99		RS-075-DE	1020 LBS.	4 13
2202-004	1.00-1.24		RS-100-DE	1610 LBS.	5 14
2202-005	1.25-1.49		RS-125-DE	1610 LBS.	5 15
2202-006	1.50-1.74		RS-150-DE	1610 LBS.	5 17
2202-007	1.75-1.99		RS-175-DE	2150 LBS.	6 19
2202-008	2.00-2.49		RS-200-DE	3260 LBS.	6 21
2202-009	2.50-2.99		RS-250-DE	3260 LBS.	6 23
2202-010	3.00-3.49		RS-300-DE	4900 LBS.	8 25
2202-011	3.50-3.99		RS-350-DE	4900 LBS.	8 27

## DOUBLE EYE, ROD CLOSING

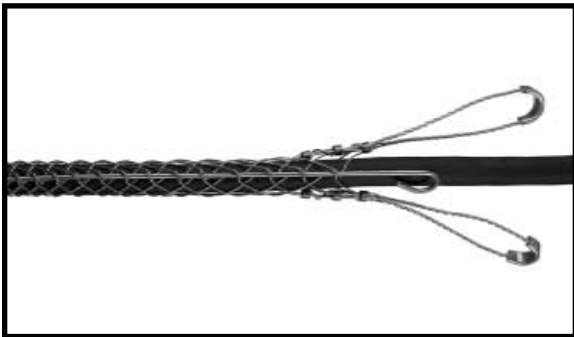

2203-001	.50-.62		RR-050-DE	530 LBS.	4 10
2203-002	.63-.74		RR-062-DE	790 LBS.	4 10
2203-003	.75-.99		RR-075-DE	1020 LBS.	4 13
2203-004	1.00-1.24		RR-100-DE	1610 LBS.	5 14
2203-005	1.25-1.49		RR-125-DE	1610 LBS.	5 15
2203-006	1.50-1.74		RR-150-DE	1610 LBS.	5 17
2203-007	1.75-1.99		RR-175-DE	2150 LBS.	6 19
2203-008	2.00-2.49		RR-200-DE	3260 LBS.	6 21
2203-009	2.50-2.99		RR-250-DE	3260 LBS.	6 23
2203-010	3.00-3.49		RR-300-DE	4900 LBS.	8 25
2203-011	3.50-3.99		RR-350-DE	4900 LBS.	8 27

E = Eye Length    M = Mesh Length at Nominal Diameter (Inches)

**CAUTION: NEVER USE GRIPS TO APPROX. BREAKING STRENGTH. REFER TO PAGE "B" FOR SAFETY AND WORKING LOAD FACTORS.**

# AMTEC SUPPORT GRIPS

- Amtec Support Grips are made of stranded tinned bronze wire.
- Stainless steel, medium lengths, and or specials, please consult factory.

## SINGLE EYE, CLOSED MESH

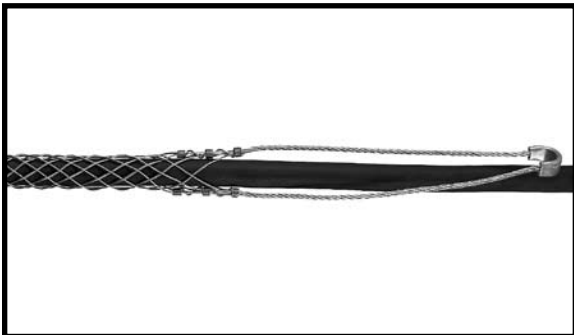

PART NUMBER	DIA.	RA.	DESCRIPTION	APPROX. BREAKING STRENGTH		LENGTH	
				E	M		
2201-013	.50	.62	R-050-SE	530 LBS.	7	10	
2201-014	.63	.74	R-062-SE	790 LBS.	8	10	
2201-015	.75	.99	R-075-SE	1020 LBS.	8	13	
2201-016	1.00	1.24	R-100-SE	1610 LBS.	9	14	
2201-017	1.25	1.49	R-125-SE	1610 LBS.	10	15	
2201-018	1.50	1.74	R-150-SE	1610 LBS.	12	17	
2201-019	1.75	1.99	R-175-SE	2150 LBS.	14	19	
2201-020	2.00	2.49	R-200-SE	3260 LBS.	16	21	
2201-021	2.50	2.99	R-250-SE	3260 LBS.	18	23	
2201-022	3.00	3.49	R-300-SE	4900 LBS.	21	25	
2201-023	3.50	3.99	R-350-SE	4900 LBS.	24	27	

## SINGLE EYE, LACE CLOSING

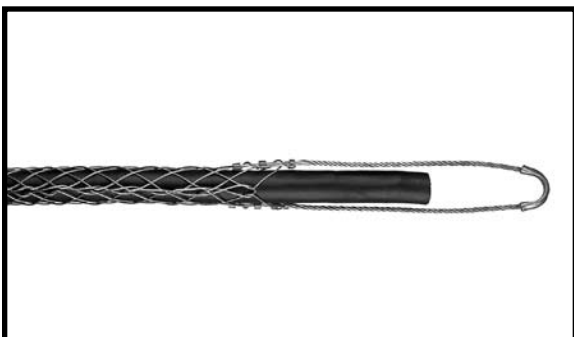

2202-013	.50	.62	RS-050-SE	530 LBS.	7	10
2202-014	.63	.74	RS-062-SE	790 LBS.	8	10
2202-015	.75	.99	RS-075-SE	1020 LBS.	8	13
2202-016	1.00	1.24	RS-100-SE	1610 LBS.	9	14
2202-017	1.25	1.49	RS-125-SE	1610 LBS.	10	15
2202-018	1.50	1.74	RS-150-SE	1610 LBS.	12	17
2202-019	1.75	1.99	RS-175-SE	2150 LBS.	14	19
2202-020	2.00	2.49	RS-200-SE	3260 LBS.	16	21
2202-021	2.50	2.99	RS-250-SE	3260 LBS.	18	23
2202-022	3.00	3.49	RS-300-SE	4900 LBS.	21	25
2202-023	3.50	3.99	RS-350-SE	4900 LBS.	24	27

## SINGLE EYE, ROD CLOSING

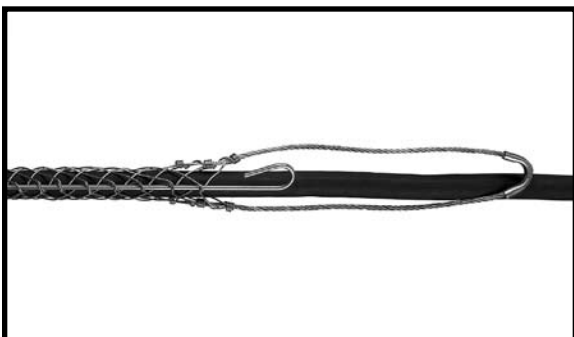

2203-013	.50	.62	RR-050-SE	530 LBS.	7	10
2203-014	.63	.74	RR-062-SE	790 LBS.	8	10
2203-015	.75	.99	RR-075-SE	1020 LBS.	8	13
2203-016	1.00	1.24	RR-100-SE	1610 LBS.	9	14
2203-017	1.25	1.49	RR-125-SE	1610 LBS.	10	15
2203-018	1.50	1.74	RR-150-SE	1610 LBS.	12	17
2203-019	1.75	1.99	RR-175-SE	2150 LBS.	14	19
2203-020	2.00	2.49	RR-200-SE	3260 LBS.	16	21
2203-021	2.50	2.99	RR-250-SE	3260 LBS.	18	23
2203-022	3.00	3.49	RR-300-SE	4900 LBS.	21	25
2203-023	3.50	3.99	RR-350-SE	4900 LBS.	24	27

E = Eye Length    M = Mesh Length at Nominal Diameter (Inches)

**CAUTION: NEVER USE GRIPS TO APPROX. BREAKING STRENGTH. REFER TO PAGE "B" FOR SAFETY AND WORKING LOAD FACTORS.**

# AMTEC SUPPORT GRIPS

- Amtec Support Grips are made of stranded tinned bronze wire.
- Stainless steel, medium lengths, and or specials, please consult factory.

## OFFSET EYE, CLOSED MESH

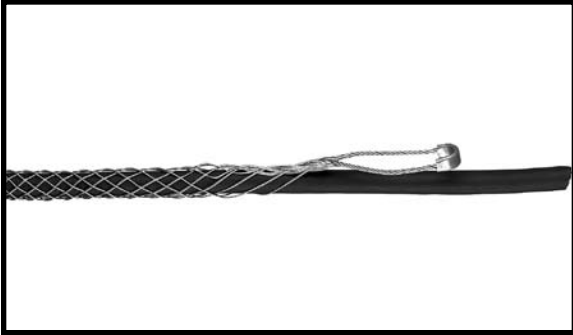

PART NUMBER	DIA. RA.	DESCRIPTION	APPROX. BREAKING STRENGTH	LENGTH	
				E	M
2201-025	.50-.62	R-050-OFS	500 LBS.	4	10
2201-026	.63-.74	R-062-OFS	750 LBS.	4	10
2201-027	.75-.99	R-075-OFS	950 LBS.	4	13
2201-028	1.00-1.24	R-100-OFS	1500 LBS.	5	14
2201-029	1.25-1.49	R-125-OFS	1500 LBS.	5	15
2201-030	1.50-1.74	R-150-OFS	1500 LBS.	5	17
2201-031	1.75-1.99	R-175-OFS	2000 LBS.	6	19
2201-032	2.00-2.49	R-200-OFS	3100 LBS.	6	21
2201-033	2.50-2.99	R-250-OFS	3100 LBS.	6	23
2201-034	3.00-3.49	R-300-OFS	3800 LBS.	9	25
2201-035	3.50-3.99	R-350-OFS	3800 LBS.	9	27

## OFFSET EYE, LACE CLOSING

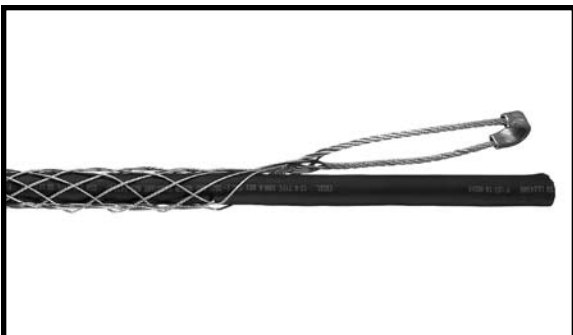

2202-025	.50-.62	RS-050-OFS	500 LBS.	4	10
2202-026	.63-.74	RS-062-OFS	750 LBS.	4	10
2202-027	.75-.99	RS-075-OFS	950 LBS.	4	13
2202-028	1.00-1.24	RS-100-OFS	1500 LBS.	5	14
2202-029	1.25-1.49	RS-125-OFS	1500 LBS.	5	15
2202-030	1.50-1.74	RS-150-OFS	1500 LBS.	5	17
2202-031	1.75-1.99	RS-175-OFS	2000 LBS.	6	19
2202-032	2.00-2.49	RS-200-OFS	3100 LBS.	6	21
2202-033	2.50-2.99	RS-250-OFS	3100 LBS.	6	23
2202-034	3.00-3.49	RS-300-OFS	3800 LBS.	9	25
2202-035	3.50-3.99	RS-350-OFS	3800 LBS.	9	27

## OFFSET EYE, ROD CLOSING

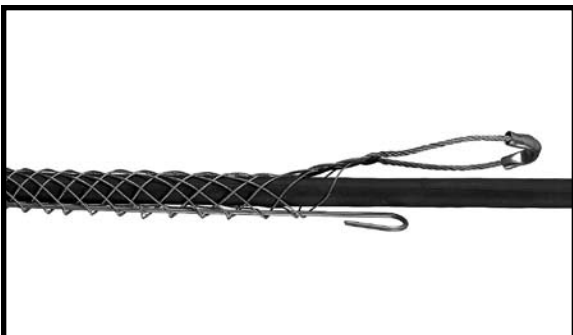

2203-025	.50-.62	RR-050-OFS	500 LBS.	4	10
2203-026	.63-.74	RR-062-OFS	750 LBS.	4	10
2203-027	.75-.99	RR-075-OFS	950 LBS.	4	13
2203-028	1.00-1.24	RR-100-OFS	1500 LBS.	5	14
2203-029	1.25-1.49	RR-125-OFS	1500 LBS.	5	15
2203-030	1.50-1.74	RR-150-OFS	1500 LBS.	5	17
2203-031	1.75-1.99	RR-175-OFS	2000 LBS.	6	19
2203-032	2.00-2.49	RR-200-OFS	3100 LBS.	6	21
2203-033	2.50-2.99	RR-250-OFS	3100 LBS.	6	23
2203-034	3.00-3.49	RR-300-OFS	3800 LBS.	9	25
2203-035	3.50-3.99	RR-350-OFS	3800 LBS.	9	27

E = Eye Length    M = Mesh Length at Nominal Diameter (Inches)

**CAUTION: NEVER USE GRIPS TO APPROX. BREAKING STRENGTH. REFER TO PAGE "B" FOR SAFETY AND WORKING LOAD FACTORS.**

# AMTEC SUPPORT GRIPS

- Amtec Support Grips are made of stranded tinned bronze wire.
- Stainless steel, medium lengths, and or specials, please consult factory.

## UNIVERSAL BAIL, CLOSED MESH

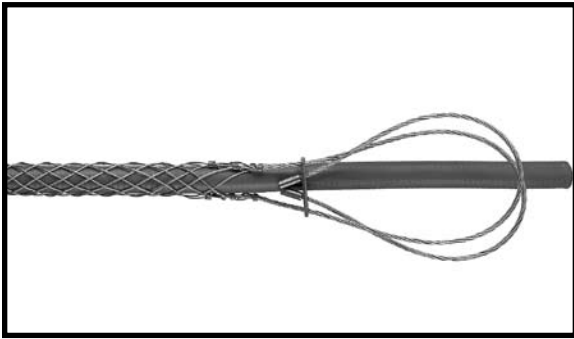

PART NUMBER	DIA.	RA.	DESCRIPTION	APPROX. BREAKING STRENGTH	LENGTH	
					E	M
2201-037	.50	.62	R-050-UB-18"	530 LBS.	18	10
2201-038	.63	.74	R-062-UB-18"	790 LBS.	18	10
2201-039	.75	.99	R-075-UB-18"	1020 LBS.	18	13
2201-040	1.00	1.24	R-100-UB-18"	1610 LBS.	18	14
2201-041	1.25	1.49	R-125-UB-18"	1610 LBS.	18	15
2201-042	1.50	1.74	R-150-UB-18"	1610 LBS.	18	17
2201-043	1.75	1.99	R-175-UB-18"	2150 LBS.	18	19
2201-044	2.00	2.49	R-200-UB-18"	3260 LBS.	18	21
2201-045	2.50	2.99	R-250-UB-18"	3260 LBS.	18	23
2201-046	3.00	3.49	R-300-UB-18"	4900 LBS.	18	25
2201-047	3.50	3.99	R-350-UB-18"	4900 LBS.	18	27

## UNIVERSAL BAIL, LACE CLOSING

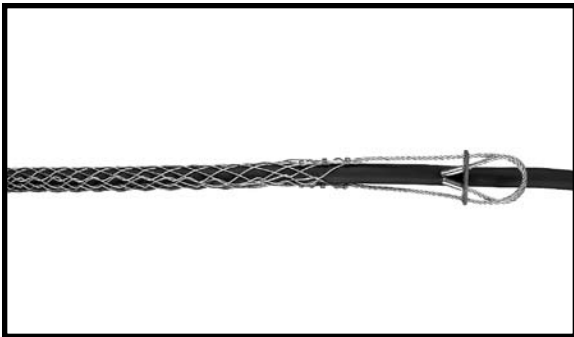

2202-037	.50	.62	RS-050-UB-18"	530 LBS.	18	10
2202-038	.63	.74	RS-062-UB-18"	790 LBS.	18	10
2202-039	.75	.99	RS-075-UB-18"	1020 LBS.	18	13
2202-040	1.00	1.24	RS-100-UB-18"	1610 LBS.	18	14
2202-041	1.25	1.49	RS-125-UB-18"	1610 LBS.	18	15
2202-042	1.50	1.74	RS-150-UB-18"	1610 LBS.	18	17
2202-043	1.75	1.99	RS-175-UB-18"	2150 LBS.	18	19
2202-044	2.00	2.49	RS-200-UB-18"	3260 LBS.	18	21
2202-045	2.50	2.99	RS-250-UB-18"	3260 LBS.	18	23
2202-046	3.00	3.49	RS-300-UB-18"	4900 LBS.	18	25
2202-047	3.50	3.99	RS-350-UB-18"	4900 LBS.	18	27

## UNIVERSAL BAIL, ROD CLOSING

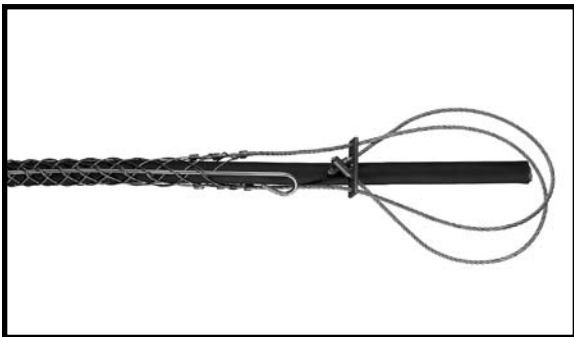

2203-037	.50	.62	RR-050-UB-18"	530 LBS.	18	10
2203-038	.63	.74	RR-062-UB-18"	790 LBS.	18	10
2203-039	.75	.99	RR-075-UB-18"	1020 LBS.	18	13
2203-040	1.00	1.24	RR-100-UB-18"	1610 LBS.	18	14
2203-041	1.25	1.49	RR-125-UB-18"	1610 LBS.	18	15
2203-042	1.50	1.74	RR-150-UB-18"	1610 LBS.	18	17
2203-043	1.75	1.99	RR-175-UB-18"	2150 LBS.	18	19
2203-044	2.00	2.49	RR-200-UB-18"	3260 LBS.	18	21
2203-045	2.50	2.99	RR-250-UB-18"	3260 LBS.	18	23
2203-046	3.00	3.49	RR-300-UB-18"	4900 LBS.	18	25
2203-047	3.50	3.99	RR-350-UB-18"	4900 LBS.	18	27

E = Eye Length    M = Mesh Length at Nominal Diameter (Inches)

**CAUTION: NEVER USE GRIPS TO APPROX. BREAKING STRENGTH. REFER TO PAGE "B" FOR SAFETY AND WORKING LOAD FACTORS.**



# AMTEC SUPPORT GRIPS

- Amtec Support Grips are made of stranded tinned bronze wire.
- Stainless steel, medium lengths, and or specials, please consult factory.

## HOOK EYE, CLOSED MESH

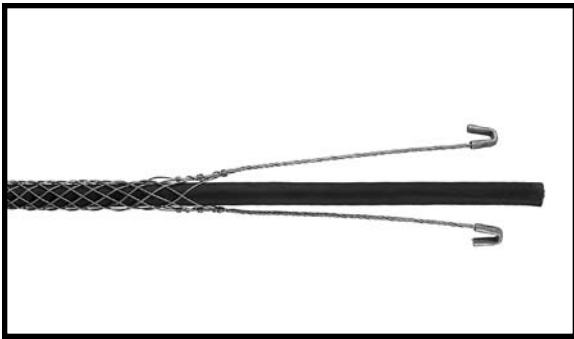

PART NUMBER	DIA.	RA.	DESCRIPTION	APPROX. BREAKING STRENGTH	LENGTH	
					E	M
2201-050	.50	.62	R-050-HE	450 LBS.	10	10
2201-051	.63	.74	R-062-HE	750 LBS.	10	10
2201-052	.75	.99	R-075-HE	1000 LBS.	10	13
2201-053	1.00	1.24	R-100-HE	1400 LBS.	10	14
2201-054	1.25	1.49	R-125-HE	1400 LBS.	10	15
2201-055	1.50	1.74	R-150-HE	1400 LBS.	10	17
2201-056	1.75	1.99	R-175-HE	1600 LBS.	10	19
2201-057	2.00	2.49	R-200-HE	2200 LBS.	10	21
2201-058	2.50	2.99	R-250-HE	2200 LBS.	10	23
2201-059	3.00	3.49	R-300-HE	3200 LBS.	10	25
2201-060	3.50	3.99	R-350-HE	3200 LBS.	10	27

## HOOK EYE, LACE CLOSING

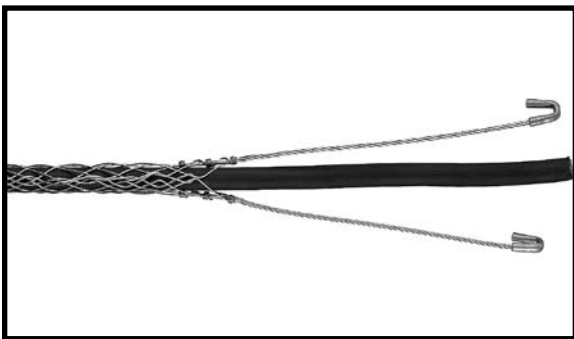

2202-050	.50	.62	RS-050-HE	750 LBS.	10	8 1/2
2202-051	.63	.74	RS-062-HE	750 LBS.	10	8 1/2
2202-052	.75	.99	RS-075-HE	1000 LBS.	10	10 1/2
2202-053	1.00	1.24	RS-100-HE	1400 LBS.	10	12 1/2
2202-054	1.25	1.49	RS-125-HE	1400 LBS.	10	14 1/2
2202-055	1.50	1.74	RS-150-HE	1400 LBS.	10	15 1/2
2202-056	1.75	1.99	RS-175-HE	1600 LBS.	10	16 1/2
2202-057	2.00	2.49	RS-200-HE	2200 LBS.	10	19 1/2
2202-058	2.50	2.99	RS-250-HE	2200 LBS.	10	21 1/2
2202-059	3.00	3.49	RS-300-HE	3200 LBS.	10	23 1/2
2202-060	3.50	3.99	RS-350-HE	3200 LBS.	10	25 1/2

## HOOK EYE, ROD CLOSING

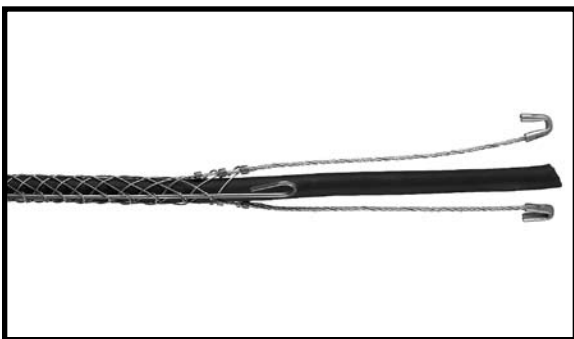

2203-050	.50	.62	RR-050-HE	750 LBS.	10	8 1/2
2203-051	.63	.74	RR-062-HE	750 LBS.	10	8 1/2
2203-052	.75	.99	RR-075-HE	1000 LBS.	10	10 1/2
2203-053	1.00	1.24	RR-100-HE	1400 LBS.	10	12 1/2
2203-054	1.25	1.49	RR-125-HE	1400 LBS.	10	14 1/2
2203-055	1.50	1.74	RR-150-HE	1400 LBS.	10	15 1/2
2203-056	1.75	1.99	RR-175-HE	1600 LBS.	10	16 1/2
2203-057	2.00	2.49	RR-200-HE	2200 LBS.	10	19 1/2
2203-058	2.50	2.99	RR-250-HE	2200 LBS.	10	21 1/2
2203-059	3.00	3.49	RR-300-HE	3200 LBS.	10	23 1/2
2203-060	3.50	3.99	RR-350-HE	3200 LBS.	10	25 1/2

E = Eye Length    M = Mesh Length at Nominal Diameter (Inches)

**CAUTION: NEVER USE GRIPS TO APPROX. BREAKING STRENGTH. REFER TO PAGE "B" FOR SAFETY AND WORKING LOAD FACTORS.**

# AMTEC HEAVY DUTY SUPPORT GRIPS

- Amtec Heavy Duty Support Grips are designed to withstand greater loads and increased stress
- Support grips are made of stranded tinned bronze wire.
- Stainless steel, medium lengths, and or specials, please consult factory.

## SINGLE EYE, CLOSED MESH , DOUBLE WEAVE

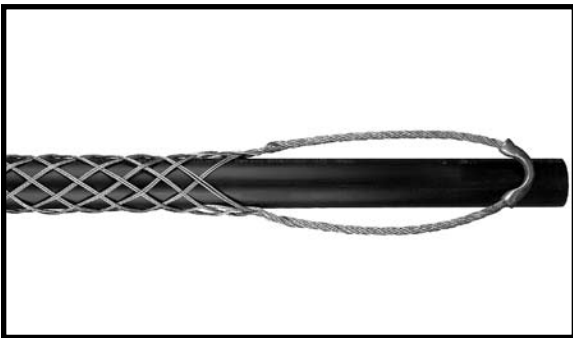

PART NUMBER	DIA. RA.	DESCRIPTION	APPROX. BREAKING STRENGTH	LENGTH	
				E	M
2206-001	.75-.99	P-075-SE	2820 LBS.	10	25
2206-002	1.00-1.24	P-100-SE	4280 LBS.	10	28
2206-003	1.25-1.49	P-125-SE	4280 LBS.	10	30
2206-004	1.50-1.99	P-150-SE	4280 LBS.	10	34

## DOUBLE EYE, CLOSED MESH, DOUBLE WEAVE

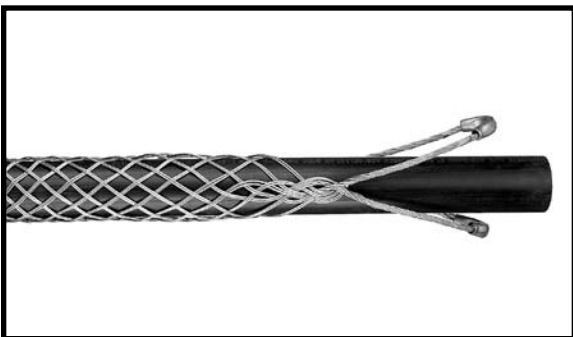

2206-006	.75-.99	P-075-DE	2820 LBS.	10	25
2206-007	1.00-1.24	P-100-DE	4280 LBS.	10	28
2206-008	1.25-1.49	P-125-DE	4280 LBS.	10	30
2206-009	1.50-1.99	P-150-DE	4280 LBS.	10	34
2206-010	2.00-2.49	P-200-DE	8050 LBS.	10	36
2206-011	2.50-2.99	P-250-DE	8050 LBS.	10	38
2206-012	3.00-3.49	P-300-DE	10060 LBS.	10	40
2206-013	3.50-3.99	P-350-DE	12070 LBS.	10	44
2206-014	4.00-4.49	P-400-DE	12070 LBS.	10	46

E = Eye Length    M = Mesh Length at Nominal Diameter (Inches)

**CAUTION: NEVER USE GRIPS TO APPROX. BREAKING STRENGTH. REFER TO PAGE "B" FOR SAFETY AND WORKING LOAD FACTORS.**

# AMTEC SERVICE DROPS

- Amtec Service Drop Grips are used in a wide variety of light duty electrical applications such as service entrance, cable tv, telephone, fiber optics, etc., in sloping, vertical, or horizontal positions.
- The mesh is made from high grade non-magnetic tin coated bronze wire.
- Amtec Service Drop Grips are easily installed wide range single and multi-weave mesh.
- A stainless steel type 302/304 non-corrosive mesh for severe application is available upon request.

## STANDARD, SINGLE EYE

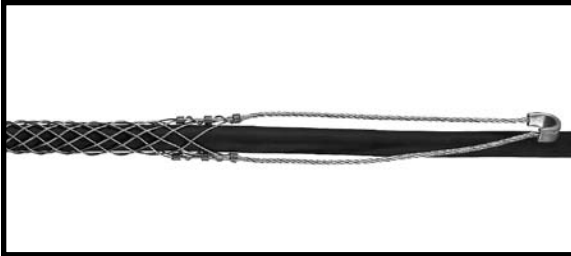

PART NUMBER	DIA.	RA.	DESCRIPTION	APPROX.	LENGTH	
				BREAKING STRENGTH	E	M
2216-001	.23-	.31	SD-23	290 LBS.	4	3 3/4
2216-002	.32-	.43	SD-32	290 LBS.	4	4 1/4
2216-003	.43-	.56	SD-43	380 LBS.	6	5
2216-004	.56-	.73	SD-56	600 LBS.	7	6
2216-005	.73-	.85	SD-73	790 LBS.	7	6 3/4
2216-006	.85-	1.00	SD-85	1020 LBS.	8	8
2216-007	1.00-	1.25	SD-100	1020 LBS.	9	9 1/2

## STANDARD, UNIVERSAL BAIL

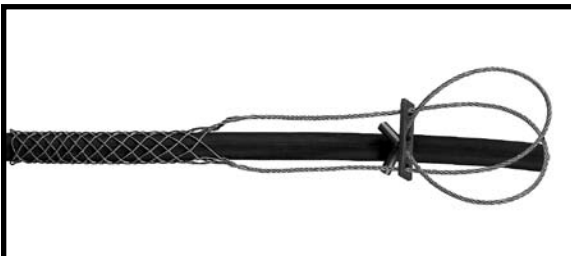

2216-008	.23-	.31	SD-23-UB	290 LBS.	8	3 3/4
2216-009	.32-	.43	SD-32-UB	290 LBS.	10	4 1/4
2216-010	.43-	.56	SD-43-UB	380 LBS.	12	5
2216-011	.56-	.73	SD-56-UB	600 LBS.	13	6
2216-012	.73-	.85	SD-73-UB	790 LBS.	14	6 3/4
2216-013	.85-	1.00	SD-85-UB	1020 LBS.	14	8
2216-014	1.00-	1.25	SD-100-UB	1020 LBS.	15	9 1/2

## HEAVY DUTY, SINGLE EYE

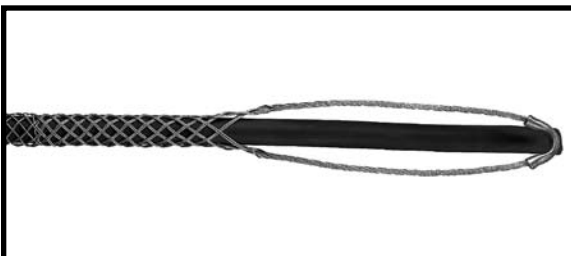

2217-001	.23-	.31	SDH-23	500 LBS.	5	5
2217-002	.32-	.43	SDH-32	500 LBS.	6	6 1/2
2217-003	.43-	.56	SDH-43	870 LBS.	6	8
2217-004	.56-	.73	SDH-56	1050 LBS.	7	9
2217-005	.73-	.85	SDH-73	1390 LBS.	8	10 1/2
2217-006	.85-	1.00	SDH-85	1790 LBS.	8	12
2217-007	1.00-	1.25	SDH-100	1790 LBS.	9	14

## HEAVY DUTY, UNIVERSAL BAIL

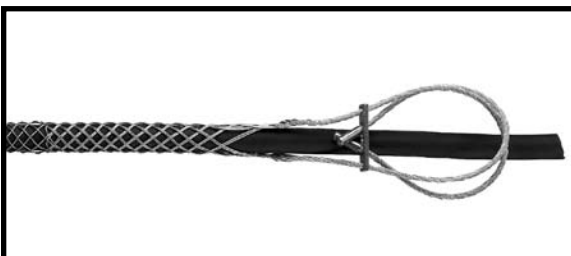

2217-008	.23-	.31	SDH-23-UB	500 LBS.	9	5
2217-009	.32-	.43	SDH-32-UB	500 LBS.	10	6 1/2
2217-010	.43-	.56	SDH-43-UB	870 LBS.	12	8
2217-011	.56-	.73	SDH-56-UB	1050 LBS.	13	9 1/2
2217-012	.73-	.85	SDH-73-UB	1390 LBS.	14	10 1/2
2217-013	.85-	1.00	SDH-85-UB	1790 LBS.	14	12
2217-014	1.00-	1.25	SDH-100-UB	1790 LBS.	15	14

E = Eye Length    M = Mesh Length at Nominal Diameter (Inches)

**CAUTION: NEVER USE GRIPS TO APPROX. BREAKING STRENGTH. REFER TO PAGE "B" FOR SAFETY AND WORKING LOAD FACTORS.**

# AMTEC CONDUIT RISER GRIPS

- Amtec Conduit Riser Support Grips are used to support cable runs in vertical or sloping standard rigid conduit.
- They are designed to prevent cable creep in conduit and help prevent cable pullouts.
- Amtec Conduit Riser Support Grips install quickly and easily with no damage to electrical cable.
- The mesh is attached to a support ring, which sits on the conduit requiring no extra hardware to attach.
- Fittings, bushings, or couplings may be threaded on the conduit with the grip in place.
- Amtec Conduit Riser Grips are made of stranded tinned bronze wire.
- Stainless steel, double weave, and or specials, please consult factory.

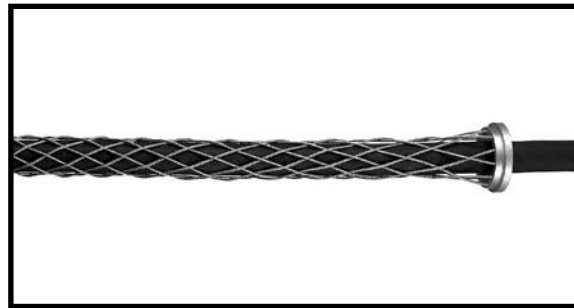

## SINGLE WEAVE, CLOSED MESH

	CABLE SIZE INCHES	.50-.62	.63-.74	.75-.99	1.00-1.24	1.25-1.49	1.50-1.74	1.75-1.99	2.00-2.49	2.50-2.99	3.00-3.49	3.50-3.99
	MODEL	R-050	R-062	R-075	R-100	R-125	R-150	R-175	R-200	R-250	R-300	R-350
	LENGTH	8"	9"	10"	11"	12"	13"	14"	17"	18"	20"	21"
CONDUIT SIZE	APX. BRK. STR. LBS.	530 290	790 435	1030 560	1610 890	1610 890	1610 890	2150 1180	3260 1795	3260 1795	4080 2245	4080 2245
3/4"	CAT. NO.	2211-001										
1"	CAT. NO.	2211-002	2211-003									
1- 1/4"	CAT. NO.	2211-004	2211-005	2211-006								
1-1/2"	CAT. NO.	2211-007	2211-008	2211-009	2211-010							
2"	CAT. NO.	2211-011	2211-012	2211-013	2211-014	2211-015						
2-1/2"	CAT. NO.	2211-016	2211-017	2211-018	2211-019	2211-020	2211-022	2211-023				
3"	CAT. NO.	2211-024	2211-025	2211-026	2211-027	2211-028	2211-029	2211-030	2211-031			
3-1/2"	CAT. NO.		2211-032	2211-033	2211-034	2211-035	2211-036	2211-037	2211-038	2211-039		
4"	CAT. NO.		2211-040	2211-041	2211-042	2211-043	2211-044	2211-045	2211-046	2211-047	2211-048	
4 1/2"	CAT. NO.			2211-049	2211-050	2211-051	2211-052	2211-053	2211-054	2211-055	2211-056	2211-057
5"	CAT. NO.			2211-058	2211-059	2211-060	2211-061	2211-062	2211-063	2211-064	2211-065	2211-066
6"	CAT. NO.			2211-067	2211-068	2211-069	2211-070	2211-071	2211-072	2211-073	2211-074	2211-075

**CAUTION: NEVER USE GRIPS TO APPROX. BREAKING STRENGTH. REFER TO PAGE "B" FOR SAFETY AND WORKING LOAD FACTORS.**



# AMTEC CONDUIT RISER GRIPS

- Amtec Conduit Riser Grips are made of stranded tinned bronze wire.
- Stainless steel, medium lengths, and or specials, please consult factory.

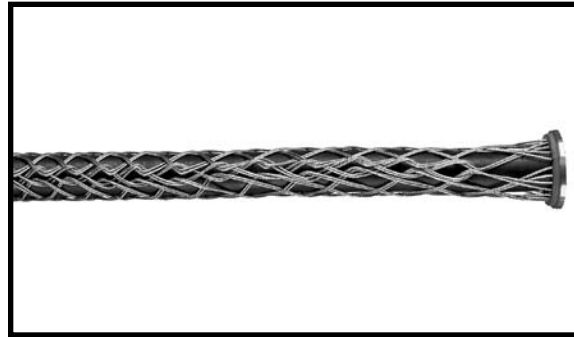

## DOUBLE WEAVE, SPLIT MESH, LACE CLOSING

	CABLE SIZE INCHES	.75-.99	1.00-1.24	1.25-1.49	1.50-1.74	1.75-1.99	2.00-2.49	2.50-2.99	3.00-3.49	3.50-3.99
	MODEL	RS-075	RS-100	RS-125	RS-150	RS-175	RS-200	RS-250	RS-300	RS-350
	LENGTH	10"	11"	12"	13"	14"	17"	18"	20"	21"
CONDUIT SIZE	APX. BRK. STR. LBS.	1580 870	2040 1125	2040 1125	2040 1125	2730 1500	4300 2365	4300 2365	5380 2955	5380 2955
1-1/4"	CAT NO	2212-006								
1-1/2"	CAT NO	2212-009	2212-010							
2"	CAT NO	2212-013	2212-014	2212-015						
2-1/2"	CAT NO	2212-018	2212-019	2212-020	2212-022	2212-023				
3"	CAT NO	2212-026	2212-027	2212-028	2212-029	2212-030	2212-031			
3-1/2"	CAT NO	2212-033	2212-034	2212-035	2212-036	2212-037	2212-038	2212-039		
4"	CAT NO	2212-041	2212-042	2212-043	2212-044	2212-045	2212-046	2212-047	2212-048	
4-1/2"	CAT NO	2212-049	2212-050	2212-051	2212-052	2212-053	2212-054	2212-055	2212-056	2212-057
5"	CAT NO	2212-058	2212-059	2212-060	2212-061	2212-062	2212-063	2212-064	2212-065	2212-066
6"	CAT NO	2212-067	2212-068	2212-069	2212-070	2212-071	2212-072	2212-073	2212-074	2212-075

**CAUTION: NEVER USE GRIPS TO APPROX. BREAKING STRENGTH. REFER TO PAGE "B" FOR SAFETY AND WORKING LOAD FACTORS.**

# AMTEC CONDUIT RISER GRIPS

- Amtec Conduit Riser Grips are made of stranded tinned bronze wire.
- Stainless steel, medium lengths, and or specials, please consult factory.

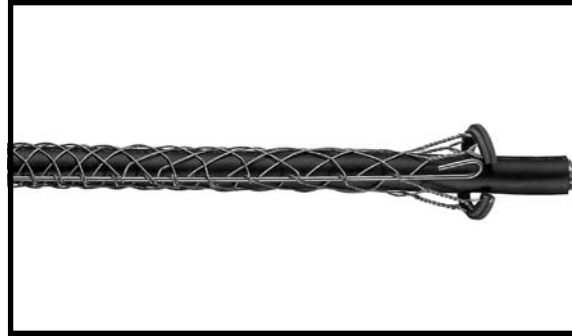

## SINGLE WEAVE, SPLIT MESH, ROD CLOSING

	CABLE SIZE INCHES	.75-.99	1.00-1.24	1.25-1.49	1.50-1.74	1.75-1.99	2.00-2.49	2.50-2.99	3.00-3.49	3.50-3.99
	MODEL	RR-075	RR-100	RR-125	RR-150	RR-175	RR-200	RR-250	RR-300	RR-350
	LENGTH	11"	12"	13"	14"	15"	16"	17"	19"	20"
CONDUIT SIZE	APX. BRK. STR. LBS.	1020 560	1610 890	1610 890	1610 890	2150 1180	3260 1795	3260 1795	4080 2245	4080 2245
1-1/4"	CAT NO	2213-006								
1-1/2"	CAT NO	2213-009	2213-010							
2"	CAT NO	2213-013	2213-014	2213-015						
2-1/2"	CAT NO	2213-018	2213-019	2213-020	2213-022	2213-023				
3"	CAT NO	2213-026	2213-027	2213-028	2213-029	2213-030	2213-031			
3-1/2"	CAT NO	2213-033	2213-034	2213-035	2213-036	2213-037	2213-038	2213-039		
4"	CAT NO	2213-041	2213-042	2213-043	2213-044	2213-045	2213-046	2213-047	2213-048	
4-1/2"	CAT NO	2213-049	2213-050	2213-051	2213-052	2213-053	2213-054	2213-055	2213-056	2213-057
5"	CAT NO	2213-058	2213-059	2213-060	2213-061	2213-062	2213-063	2213-064	2213-065	2213-066
6"	CAT NO	2213-067	2213-068	2213-069	2213-070	2213-071	2213-072	2213-073	2213-074	2213-075

**CAUTION: NEVER USE GRIPS TO APPROX. BREAKING STRENGTH. REFER TO PAGE "B" FOR SAFETY AND WORKING LOAD FACTORS.**

# AMTEC CONDUIT RISER

## Conduit Rings

Select Conduit Ring Dimension from chart to the right.  
Conduit Rings are cast bronze, zinc plated to resist corrosion.

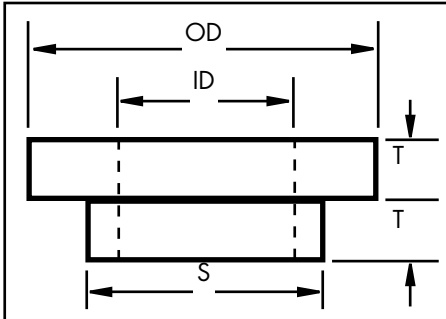

## Conduit Ring Dimensions

CONDUIT SIZE	RING NO.	O.D.	I.D.	S	T
3/4"	C-3/4"	.94	.62	-	.19
1"	C-1	1.31	.93	-	.19
1-1/4"	C-1-1/4	1.50	1.03	1.31	.16
1-1/2"	C-1-1/2	1.76	1.23	1.52	.16
2"	C-2	2.23	1.55	1.97	.16
2-1/2"	C-2-1/2	2.67	2.05	2.40	.16
3"	C-3	3.20	2.55	2.97	.22
3-1/2"	C-3-1/2	3.80	3.05	3.47	.22
4"	C-4	4.30	3.55	3.94	.22
4-1/2"	C-4-1/2	4.80	4.03	4.45	.22
5"	C-5	5.30	4.46	4.96	.22
6"	C-6	6.30	5.36	5.96	.25

**For Amtec Conduit Riser Grips only  
use to determine grip size when multiple cables are held  
in a Single Conduit Riser Grip**

### For Cables Of Equal Diameters

- Under "Number of cables in one grip," find diameter of your cable in vertical column.
- Read grip size and grip diameter range to the right.
- If your diameter is the maximum of the range shown, go to the next larger size for split grips, stay with the same size for closed grips.
- Example: 3 cables, each with .85 diameter, for a closed grip select the 1.50 - 1.74 range, for a split grip use 1.75 - 1.99.

NUMBER OF EQUAL DIAMETER CABLES IN ONE GRIP							
2	3	4	5	6 and 7	8	9	GRIP DIAM. RANGE
.29-.36 .37-.43 .44-.58	.24-.30 .31-.36 .37-.48	.21-.25 .26-.30 .31-.41	.18-.22 .23-.27 .28-.36	.16-.20 .21-.24 .25-.32	.15-.18 .19-.22 .23-.29	.14-.17 .18-.20 .21-.27	.50-.62 .63-.74 .75-.99
.59-.72 .73-.87 .88-1.01	.49-.60 .61-.72 .73-.85	.42-.51 .52-.61 .62-.71	.37-.45 .46-.54 .55-.63	.33-.40 .41-.48 .49-.56	.30-.36 .37-.43 .44-.51	.28-.34 .35-.40 .41-.47	1.00-1.24 1.25-1.49 1.50-1.74
1.02-1.16 1.17-1.44 1.45-1.73	.86-.96 .97-1.20 1.21-1.45	.72-.81 .82-1.02 1.03-1.22	.64-.72 .73-.90 .91-1.08	.57-.64 .65-.80 .81-.96	.52-.58 .59-.72 .73-.87	.48-.54 .55-.67 .68-.81	1.75-1.99 2.00-2.49 2.50-2.99
1.74-2.02 2.03-2.31	1.46-1.69 1.70-1.93	1.23-1.43 1.44-1.63	1.09-1.26 1.27-1.44	.97-1.11 1.12-1.27	.83-1.01 1.02-1.15	.82-.94 .95-1.08	3.00-3.49 3.50-3.99

**CAUTION: NEVER USE GRIPS TO APPROX. BREAKING STRENGTH. REFER TO PAGE "B" FOR SAFETY AND WORKING LOAD FACTORS.**

# AMTEC UTILITY PULLING GRIPS

- Amtec Utility Pulling Grips are made of high strength galvanized steel strand.
- Pulling Grips are double weave for added strength with greater mesh contact on the cable to handle longer or heavier pulling jobs.

## STANDARD, MACHINED EYE



PART NUMBER	DIA.	RA.	DESCRIPTION	APPROX. BREAKING STRENGTH	LENGTH	
					E	M
3301-001	.50	.61	UP-50-ME	5600 LBS.	5	16
3301-002	.62	.74	UP-62-ME	6800 LBS.	5	16
3301-003	.75	.99	UP-75-ME	9600 LBS.	6	32
3301-004	1.00	1.49	UP-100-ME	16400 LBS.	7	33
3301-005	1.50	1.99	UP-150-ME	16400 LBS.	7	34
3301-006	2.00	2.49	UP-200-ME	27200 LBS.	9	36
3301-007	2.50	2.99	UP-250-ME	33000 LBS.	10	38
3301-008	3.00	3.49	UP-300-ME	41000 LBS.	10	39
3301-009	3.50	3.99	UP-350-ME	48000 LBS.	10	41
3301-010	4.00	4.49	UP-400-ME	48000 LBS.	10	42
3301-011	4.50	4.99	UP-450-ME	48000 LBS.	10	58
3301-012	5.00	5.99	UP-500-ME	48000 LBS.	10	60
3301-013	6.00	6.99	UP-600-ME	48000 LBS.	10	66

## STANDARD, FLEXIBLE EYE

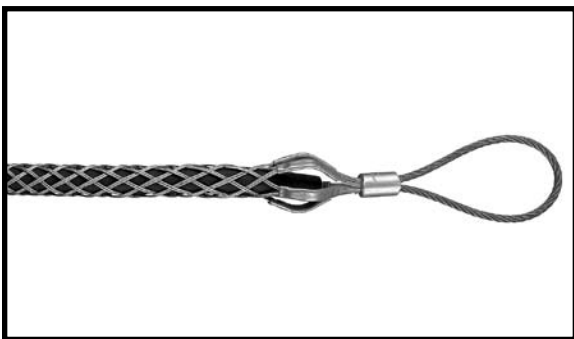

3304-001	.50	.61	UP-50-FE	4500 LBS.	5	16
3304-002	.62	.74	UP-62-FE	5600 LBS.	5	16
3304-003	.75	.99	UP-75-FE	6800 LBS.	6	32
3304-004	1.00	1.49	UP-100-FE	9600 LBS.	7	33
3304-005	1.50	1.99	UP-150-FE	16400 LBS.	7	34
3304-006	2.00	2.49	UP-200-FE	18500 LBS.	9	36
3304-007	2.50	2.99	UP-250-FE	24500 LBS.	10	38
3304-008	3.00	3.49	UP-300-FE	24500 LBS.	10	39
3304-009	3.50	3.99	UP-350-FE	31000 LBS.	10	41

For shorter or longer mesh please consult factory.

**CAUTION: NEVER USE GRIPS TO APPROX. BREAKING STRENGTH. REFER TO PAGE "B" FOR SAFETY AND WORKING LOAD FACTORS.**



# AMTEC LIGHT DUTY PULLING GRIPS

- Amtec Light Duty Pulling Grips are made of high grade galvanized steel strand.
- They are single weave with a flexible eye for easy attachment to a pulling line.
- Amtec Light Duty Pulling Grips are used in general underground electrical construction where pulling tensions are low.

## SHORT



PART NUMBER	DIA.	RA.	DESCRIPTION	APPROX. BREAKING STRENGTH	LENGTH	
					E	M
3303-001	.50	.61	LD-050-S	2800 LBS.	5	11
3303-002	.62	.74	LD-062-S	2800 LBS.	5	11
3303-003	.75	.99	LD-075-S	4000 LBS.	6	12
3303-004	1.00	1.24	LD-100-S	5300 LBS.	7	13
3303-005	1.25	1.49	LD-125-S	5300 LBS.	7	14
3303-006	1.50	1.74	LD-150-S	6800 LBS.	8	15
3303-007	1.75	1.99	LD-175-S	8500 LBS.	8	17
3303-008	2.00	2.49	LD-200-S	8500 LBS.	9	18
3303-009	2.50	2.99	LD-250-S	10600 LBS.	9	18
3303-010	3.00	3.49	LD-300-S	14700 LBS.	10	20

## STANDARD



3303-011	.50	.61	LD-050	2800 LBS.	5	16
3303-012	.62	.74	LD-062	2800 LBS.	5	16
3303-013	.75	.99	LD-075	4000 LBS.	6	20
3303-014	1.00	1.24	LD-100	6800 LBS.	7	20
3303-015	1.25	1.49	LD-125	6800 LBS.	7	21
3303-016	1.50	1.99	LD-150	6800 LBS.	8	23
3303-017	2.00	2.49	LD-200	8500 LBS.	9	25
3303-018	2.50	2.99	LD-250	10600 LBS.	9	27
3303-019	3.00	3.50	LD-300	14700 LBS.	10	30
3303-020	3.50	3.99	LD-350	14700 LBS.	10	32

## JUNIOR PULLING

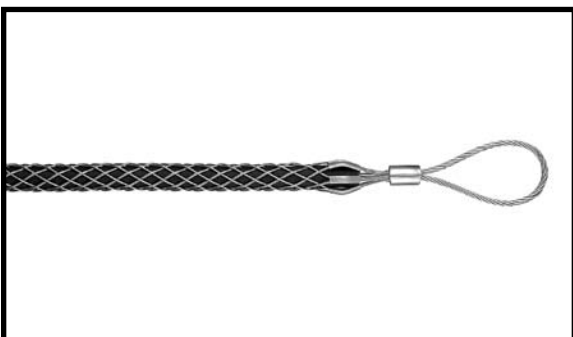

3305-002	.25	.36	JP-25	450 LBS.	3 1/4	4 1/4
3305-003	.37	.49	JP-37	900 LBS.	3 1/4	7
3305-004	.50	.61	JP-50	1300 LBS.	4 1/4	8 1/2
3305-005	.62	.74	JP-62	1950 LBS.	5	10
3305-006	.75	.99	JP-75	2800 LBS.	5 3/4	10
3305-007	1.00	1.25	JP-100	3900 LBS.	6 1/2	11 1/2
3305-008	.25	1.25	JP KIT			
INCLUDES:	JP-25, JP-37					
	JP-50, JP-62					
	JP-75, JP-100					

E = Eye Length    M = Mesh Length at Nominal Diameter (Inches)

**CAUTION: NEVER USE GRIPS TO APPROX. BREAKING STRENGTH. REFER TO PAGE "B" FOR SAFETY AND WORKING LOAD FACTORS.**

# AMTEC SLACK PULLING GRIPS

- Amtec Slack Pulling Grips are made of galvanized steel and come in three styles with a single offset eye for easy attachment to a pulling line.
- Closed, when the cable end is accessible, split lace and rod closing when cable end is not accessible.
- Grips are used in pulling slack for final placement of underground cable after it has been pulled and for removing cable.
- Short mesh to be used in restricted space for short pulls and longer mesh for higher pulling loads where space is not restricted.

## STANDARD

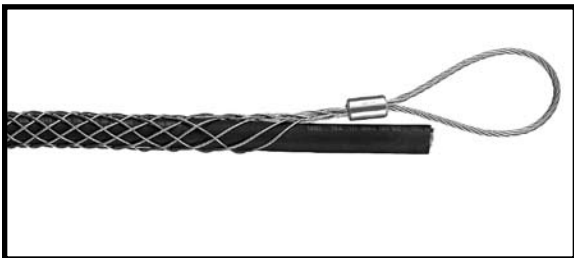

PART NUMBER	DIA.	RA.	DESCRIPTION	APPROX. BREAKING STRENGTH	LENGTH	
					E	M
3308-001	.50	.61	SPG-50-SW	1000 LBS.	6	11
3308-002	.62	.74	SPG-62-SW	1200 LBS.	6	12
3308-003	.75	.99	SPG-75-SW	1750 LBS.	7	12
3308-004	1.00	1.24	SPG-100-SW	2500 LBS.	8	15
3308-005	1.25	1.49	SPG-125-SW	2500 LBS.	8	16
3308-006	1.50	1.74	SPG-150-SW	3000 LBS.	9	17
3308-007	1.75	1.99	SPG-175-SW	3500 LBS.	10	18
3308-008	2.00	2.49	SPG-200-SW	5000 LBS.	10	19
3308-009	2.50	2.99	SPG-250-SW	5000 LBS.	10	20
3308-010	3.00	3.49	SPG-300-SW	8000 LBS.	12	21
3308-011	3.50	3.99	SPG-350-SW	8000 LBS.	12	22

## STANDARD DOUBLE WEAVE

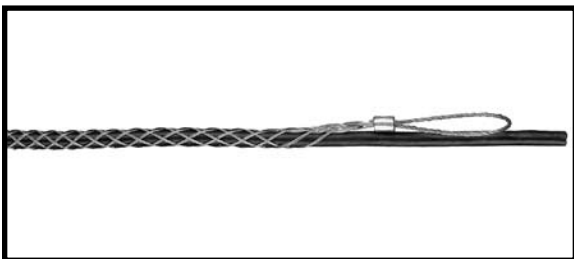

3308-015	.75	.99	SPG-75-DW	2600 LBS.	7	12
3308-016	1.00	1.24	SPG-100-DW	4000 LBS.	8	15
3308-017	1.25	1.49	SPG-125-DW	5400 LBS.	8	16
3308-018	1.50	1.74	SPG-150-DW	6600 LBS.	9	17
3308-019	1.75	1.99	SPG-175-DW	10000 LBS.	10	18
3308-020	2.00	2.49	SPG-200-DW	11000 LBS.	10	19
3308-021	2.50	2.99	SPG-250-DW	11000 LBS.	10	20
3308-022	3.00	3.49	SPG-300-DW	14500 LBS.	12	21
3308-023	3.50	3.99	SPG-350-DW	14500 LBS.	12	22

## LONG DOUBLE WEAVE



3308-026	.75	.99	SPG-75-DW-L	2600 LBS.	7	20
3308-027	1.00	1.24	SPG-100-DW-L	4000 LBS.	8	20
3308-028	1.25	1.49	SPG-125-DW-L	5400 LBS.	8	23
3308-029	1.50	1.99	SPG-150-DW-L	10000 LBS.	9	25
3308-030	2.00	2.49	SPG-200-DW-L	11000 LBS.	10	26
3308-031	2.50	2.99	SPG-250-DW-L	11000 LBS.	10	29
3308-032	3.00	3.49	SPG-300-DW-L	14500 LBS.	12	32
3308-033	3.50	3.99	SPG-350-DW-L	14500 LBS.	12	35

E = Eye Length    M = Mesh Length at Nominal Diameter (Inches)

**CAUTION: NEVER USE GRIPS TO APPROX. BREAKING STRENGTH. REFER TO PAGE "B" FOR SAFETY AND WORKING LOAD FACTORS.**

# AMTEC SLACK PULLING GRIPS

- Amtec Slack Pulling Grips are made of galvanized steel and come in three styles with a single offset eye for easy attachment to a pulling line.
- Closed, when the cable end is accessible, split lace and rod closing when cable end is not accessible.
- Grips are used in pulling slack for final placement of underground cable after it has been pulled and for removing cable.
- Short mesh to be used in restricted space for short pulls, and longer mesh for higher pulling loads where space is not restricted.

## STANDARD LACE CLOSING

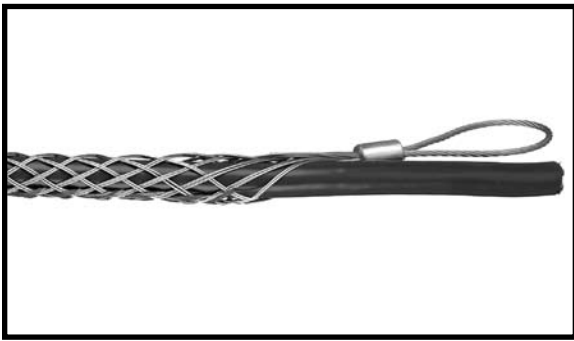

PART NUMBER	DIA.	RA.	DESCRIPTION	APPROX. BREAKING STRENGTH	LENGTH	
					E	M
3309-001	.75	.99	SPGS-75-DW	2500 LBS.	7	12
3309-002	1.00	1.24	SPGS-100-DW	3500 LBS.	8	15
3309-003	1.25	1.49	SPGS-125-DW	4000 LBS.	8	16
3309-004	1.50	1.74	SPGS-150-DW	4000 LBS.	9	17
3309-005	1.75	1.99	SPGS-175-DW	4000 LBS.	10	18
3309-006	2.00	2.49	SPGS-200-DW	4000 LBS.	10	19
3309-007	2.50	2.99	SPGS-250-DW	4000 LBS.	10	20
3309-008	3.00	3.49	SPGS-300-DW	4000 LBS.	12	21
3309-009	3.50	3.99	SPGS-350-DW	4000 LBS.	12	22

## STANDARD ROD CLOSING

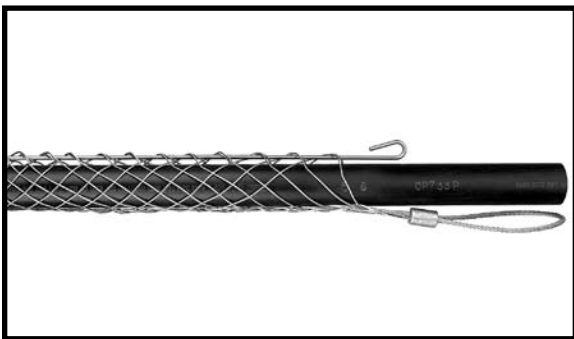

3310-001	.50	.61	SPGR-50-SW	1500 LBS.	7	6
3310-002	.62	.74	SPGR-62-SW	1800 LBS.	7	8
3310-003	.75	.99	SPGR-75-SW	2200 LBS.	7	10
3310-004	1.00	1.24	SPGR-100-SW	3400 LBS.	8	12
3310-005	1.25	1.49	SPGR-125-SW	4500 LBS.	8	14
3310-006	1.50	1.74	SPGR-150-SW	5800 LBS.	9	15
3310-007	1.75	1.99	SPGR-175-SW	7600 LBS.	10	16
3310-008	2.00	2.49	SPGR-200-SW	9000 LBS.	10	19
3310-009	2.50	2.99	SPGR-250-SW	11000 LBS.	10	20
3310-010	3.00	3.49	SPGR-300-SW	12000 LBS.	12	21
3310-011	3.50	3.99	SPGR-350-SW	12000 LBS.	12	24

E = Eye Length    M = Mesh Length at Nominal Diameter (Inches)

**CAUTION: NEVER USE GRIPS TO APPROX. BREAKING STRENGTH. REFER TO PAGE "B" FOR SAFETY AND WORKING LOAD FACTORS.**

# AMTEC TUBE GRIPS

- Amtec Tube Grips are made of galvanized steel in either single or double weave.
- They are used as a temporary splice for ropes and wire ropes as well as cable reinforcements.

## SINGLE WEAVE

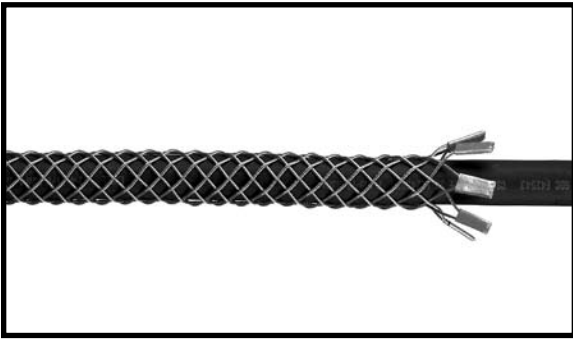

PART NUMBER	DIA. RA.	DESCRIPTION	APPROX. BREAKING STRENGTH
1303-001	.19-.24	TG-19-7"	400 LBS.
1303-002	.25-.37	TG-25-8"	400 LBS.
1303-003	.37-.50	TG-37-18"	1700 LBS.
1303-004	.50-.62	TG-50-18"	2500 LBS.
1303-005	.50-.62	TG-50-24"	2500 LBS.
1303-006	.62-.74	TG-62-18"	3100 LBS.
1303-007	.62-.74	TG-62-24"	3100 LBS.
1303-008	.62-.74	TG-62-36"	3100 LBS.
1303-009	.75-.99	TG-75-24"	5000 LBS.
1303-010	.75-.99	TG-75-36"	5000 LBS.
1303-011	.75-.99	TG-75-48"	5000 LBS.
1303-012	.75-.99	TG-75-60"	5000 LBS.
1303-013	.75-.99	TG-75-72"	5000 LBS.
1303-014	1.00-1.49	TG-100-24"	6400 LBS.
1303-015	1.00-1.49	TG-100-36"	6400 LBS.
1303-016	1.00-1.49	TG-100-48"	6400 LBS.
1303-017	1.00-1.49	TG-100-60"	6400 LBS.
1303-018	1.00-1.49	TG-100-72"	6400 LBS.
1303-019	1.50-1.99	TG-150-36"	9700 LBS.
1303-020	1.50-1.99	TG-150-48"	9700 LBS.
1303-021	1.50-1.99	TG-150-60"	9700 LBS.
1303-022	1.50-1.99	TG-150-72"	9700 LBS.

## DOUBLE WEAVE

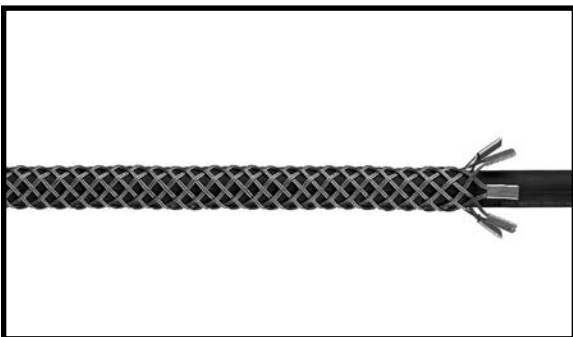

1304-001	.37-.49	TGD-37-18"	3500 LBS.
1304-002	.50-.62	TGD-50-18"	3500 LBS.
1304-003	.50-.62	TGD-50-24"	3500 LBS.
1304-004	.62-.74	TGD-62-18"	4400 LBS.
1304-005	.62-.74	TGD-62-24"	4400 LBS.
1304-006	.62-.74	TGD-62-36"	4400 LBS.
1304-007	.75-.99	TGD-75-24"	7500 LBS.
1304-008	.75-.99	TGD-75-36"	7500 LBS.
1304-009	.75-.99	TGD-75-48"	7500 LBS.
1304-010	.75-.99	TGD-75-60"	7500 LBS.
1304-011	.75-.99	TGD-75-72"	7500 LBS.
1304-012	1.00-1.49	TGD-100-24"	10000 LBS.
1304-013	1.00-1.49	TGD-100-36"	10000 LBS.
1304-014	1.00-1.49	TGD-100-48"	10000 LBS.
1304-015	1.00-1.49	TGD-100-60"	10000 LBS.
1304-016	1.00-1.49	TGD-100-72"	10000 LBS.
1304-017	1.50-1.99	TGD-150-36"	16000 LBS.
1304-018	1.50-1.99	TGD-150-48"	16000 LBS.
1304-019	1.50-1.99	TGD-150-60"	16000 LBS.
1304-020	1.50-1.99	TGD-150-72"	16000 LBS.

**CAUTION: NEVER USE GRIPS TO APPROX. BREAKING STRENGTH. REFER TO PAGE "B" FOR SAFETY AND WORKING LOAD FACTORS.**



# AMTEC SUPPORT SLINGS

- Amtec support slings have a wide variety of uses. They serve as hangers, tie downs, handles, hitches, containing devices as well as tackle & slings. This unique device assembles and disassembles very easily with the lugs on the bail end sliding into and out of the keyed openings on the sliding bar.
- Once in place the slings conform to the shape of the object being supported. The locking mechanism is securely created by the load distribution of the objects supported. When the weight is removed the bails may be easily and safely unlocked.
- Slings may be made of galvanized steel or stainless steel to suit your application.

## GALVANIZED STEEL SLING

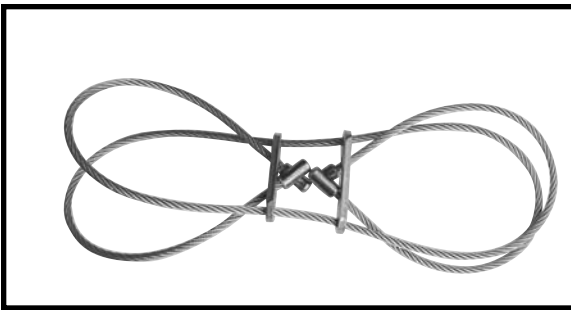

CATALOG NUMBER	LENGTH - "L"	APPROX. BREAKING STRENGTH SEE NOTE BELOW
<u>GALVANIZED STEEL</u>	<u>BALE FULLY EXTENDED</u>	<u>POUNDS</u>
203-12-001	12"	2200
203-12-002	18"	2200
203-12-003	24"	2200
203-12-004	36"	2200
203-12-005	48"	2200

## STAINLESS STEEL SLING

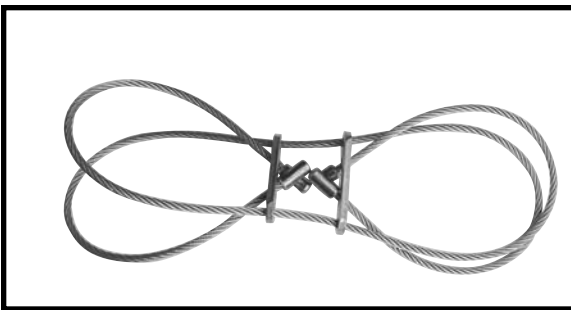

CATALOG NUMBER	LENGTH - "L"	APPROX. BREAKING STRENGTH SEE NOTE BELOW
<u>STAINLESS STEEL</u>	<u>BALE FULLY EXTENDED</u>	<u>POUNDS</u>
204-12-001	12"	2200
204-12-002	18"	2200
204-12-003	24"	2200
204-12-004	36"	2200
204-12-005	48"	2200

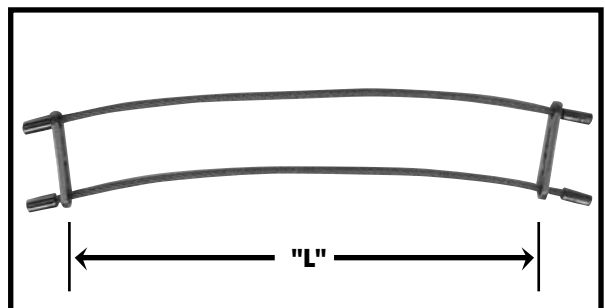

### Working Loads

Approximate breaking strengths listed are of New Unused Slings. These strengths are shown for minimum diameter of 1/2" thru bale and used for static load conditions only.

**CAUTION: NEVER USE GRIPS TO APPROX. BREAKING STRENGTH. REFER TO PAGE "B" FOR SAFETY AND WORKING LOAD FACTORS.**

# AMTEC HOSE CONTAINMENT GRIPS

- For full or partial containment of high pressure hoses Amtec Corp. manufactures a full line of grips made of type 302/304 CRES 18-8 "stainless steel". Type 316 CRES "stainless steel" is available upon request.
- Please consult factory to determine correct grip for your application. Engineering is available to custom design or modify per your needs.

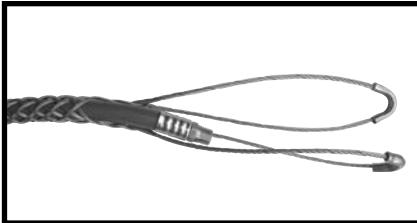

## Type E

From 1/4" Dia. to 3 1/2" Dia. double eye grips available in various lengths.



## Type F

For AN 818 (-) 4 Thru (-) 24 "B" Nut Hose Fittings Hose Diameters 1/4" thru 2 3/8".

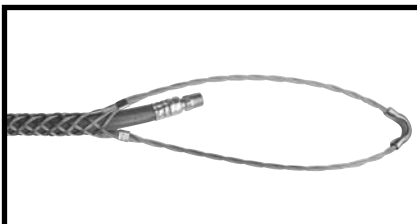

## Type A

From 1/4" Dia. to 3 1/2" Dia. single eye grips available in various lengths.

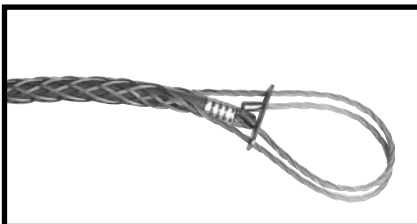

## Type U

From 1/4" Dia. to 3 1/2" Dia. universal bale grips available in various lengths.

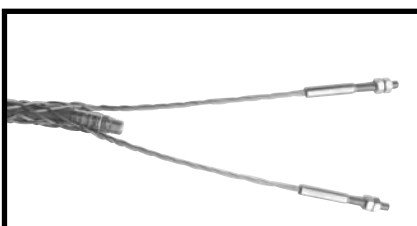

## Type Y

From 1/4" Dia. to 3 1/2" Dia. double eye threaded studs grips available in various lengths.



## Type T

From 1/4" Dia. to 3 1/2" Dia. tube grips available in various lengths.

**CAUTION: NEVER USE GRIPS TO APPROX. BREAKING STRENGTH. REFER TO PAGE "B" FOR SAFETY AND WORKING LOAD FACTORS.**

# AMTEC HOSE CONTAINMENT

Technical Data

- Hose Containment grips are used to assist in preventing high pressure hoses from whipping violently in case of hose failure.
- Widely used by NASA and the Military along with general industry.
- They are designed for flexible hose systems which transmit fluids and gases under pressure.

**chart "B"**

EYE TYPE	STD EYE LENGTH
E	8"
A	10"
U	12" OR 24"
Y	10"
<b>**SPECIAL LENGTHS AVAILABLE UPON REQUEST</b>	

**chart "A"**

AN818-B NUT DASH NO								
-4	-5	-6	-8	-10	-12	-16	-20	-24
AN818-B NUT - HEX DIM. ACROSS FLAT								
.56	.62	.68	.87	1.00	1.25	1.50	2.00	2.25
<b>Determine nut dash size if attaching to AN818-B nut. Provide complete drawing if not attaching to AN818-B nut.</b>								

**chart "C"**

HOSE O.D.	STANDARD MESH LENGTH FEET					
	1	2	3	4	5	6
1/8" to 1/2"	X	X**				
1/2" to 1"	X	X**	X			
1" to 1 1/4"	X	X**	X	X		
1 1/4" to 2 1/2"	X	X	X**	X	X	
2 1/2" to 4"	X	X	X	X**	X	X
** =partial hose contain min. mesh length X = available lengths for total hose containment						

## COMPLETE EACH REQUIREMENT:

**QTY REQUIRED:** \_\_\_\_\_

**PRESSURE:** Hose rated working pressure: \_\_\_\_\_

**HOSE JACKET:** "R" = rubber or neoprene \_\_\_\_\_  
"M" = metallic braid \_\_\_\_\_

**HOSE O.D.:** \_\_\_\_\_

**HOSE I.D.:** \_\_\_\_\_

**LARGEST DIA.:** that grip must pass over: \_\_\_\_\_

**GRIP TYPE:** see PG 20 \_\_\_\_\_

**ATTACHMENT EYE LENGTH:** see chart "B" \_\_\_\_\_  
(use chart "B" for type E, A, U and Y)  
(use chart "A" for type "F")  
(for type "T", indicate "T")

**MESH LENGTH:** use chart "C" \_\_\_\_\_

## CONTACT INFO:

NAME: \_\_\_\_\_

COMPANY NAME: \_\_\_\_\_

ADDRESS: \_\_\_\_\_

PHONE: \_\_\_\_\_

FAX: \_\_\_\_\_

EMAIL: \_\_\_\_\_

**CAUTION: NEVER USE GRIPS TO APPROX. BREAKING STRENGTH. REFER TO PAGE "B" FOR SAFETY AND WORKING LOAD FACTORS.**

# AMTEC STRAIN RELIEF

- Amtec Strain Relief Grips are wide range mesh construction with single weave, galvanized steel mesh.
- The one piece design is easily installed.
- Amtec Strain Relief Grips are used to connect flexible cord or bus drop cable to electrical enclosures, also prevents cord or cable pullout.
- Insulating bushing available for non-insulated aluminum fittings.
- Available with locknut and pvc gasket for a dirt and dust free seal.
- Dry locations only.

## SR SERIES Non-Insulated Wide Range Strain Relief

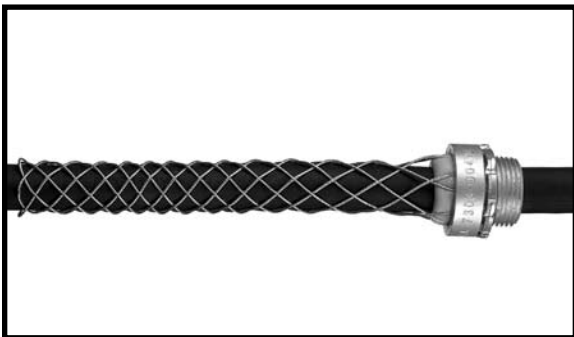

PART NUMBER	DIA. RA.	DESCRIPTION	THREAD SIZE NPT (INCHES)	LENGTH @ NOM DIA. (IN.)
7303-001	.24-.32	SR-022	1/2	3 1/4
7303-002	.32-.43	SR-030	1/2	3 3/4
7303-003	.43-.54	SR-040	1/2	4 3/4
7303-004	.54-.73	SR-052	3/4	6 1/2
7303-005	.73-.97	SR-070	1	7
7303-006	.97-1.25	SR-094	1 1/4	9



LISTED 4D55

DRY LOCATION ONLY

## SRP SERIES Insulated Wide Range Strain Relief with Insulating Bushing

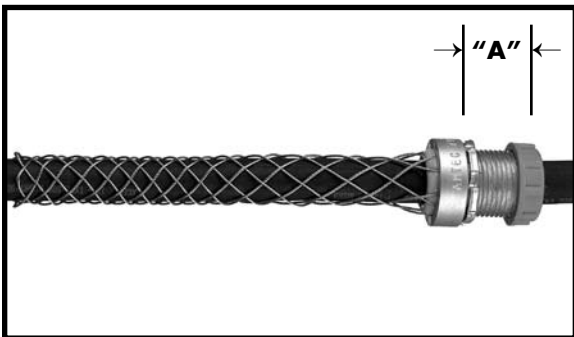

PART NUMBER	DIA. RA.	DESC.	MESH THREAD SIZE (IN)	LENGTH NOM DIA	DIM. A (INCHES)
7303-008	.24-.32	SRP-022	1/2 N.P.S.	3 1/4	1
7303-009	.32-.43	SRP-030	1/2 N.P.S.	3 3/4	1
7303-010	.43-.54	SRP-040	1/2 N.P.S.	4 3/4	1
7303-011	.54-.73	SRP-052	3/4 N.P.S.	6 1/2	1
7303-012	.73-.97	SRP-070	1 N.P.S.	7	1 3/16
7303-013	.97-1.25	SRP-094	1 1/4 N.P.S.	9	1 3/16
7303-014	1.25-1.50	SRP-120	1 1/2 N.P.T.	11 3/4	1 3/16
7303-015	1.50-1.70	SRP-140	2 N.P.T.	13 1/4	1 3/8
7303-016	1.70-2.00	SRP-162	2 1/2 N.P.T.	13 1/2	1 1/2
7303-017	2.00-2.45	SRP-200	2 1/2 N.P.T.	13 3/4	1 1/2



LISTED 4D55

DRY LOCATION ONLY

**CAUTION: NEVER USE GRIPS TO APPROX. BREAKING STRENGTH. REFER TO PAGE "B" FOR SAFETY AND WORKING LOAD FACTORS.**

# AMTEC BUS DROP GRIPS

- Amtec Bus Drop Grips are made of high strength galvanized steel strand.
- Stainless is available upon request.
- Amtec Bus Drop Grips are easily installed and absorb tension, vibration, and pull with no damage.
- They support flexible cord or Bus Drop Cable at bus duct or industrial areas.
- Single eye can be used with springs by disassembling draw bar from coil, placing through eye and replacing draw bar.
- Hook eyes available, please consult factory.

## SINGLE EYE, WIDE RANGE

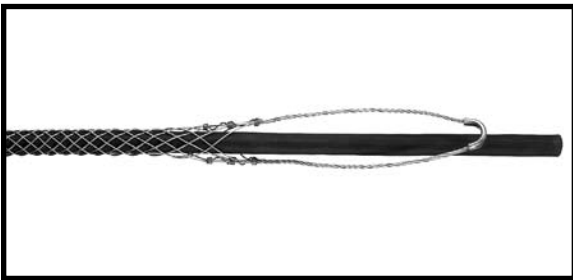

PART NUMBER	DIA.	RA.	DESCRIPTION	APPROX. BREAKING STRENGTH	LENGTH E* M
7304-001	.22-	.32	BD-022	350 LBS.	3 3 1/2**
7304-002	.30-	.43	BD-030	450 LBS.	4 4
7304-003	.41-	.56	BD-041	550 LBS.	6 4 3/4
7304-004	.53-	.73	BD-053	1000 LBS.	7 6
7304-005	.70-	.85	BD-070	1400 LBS.	7 6 3/4
7304-006	.82-	1.00	BD-082	1400 LBS.	8 8
7304-007	.96-	1.25	BD-096	1500 LBS.	9 9 1/2
7304-008	1.25-	1.50	BD-125	1800 LBS.	10 12 1/2**

c  US LISTED 4D55

**DRY LOCATION ONLY**

## UNIVERSAL BAIL, WIDE RANGE

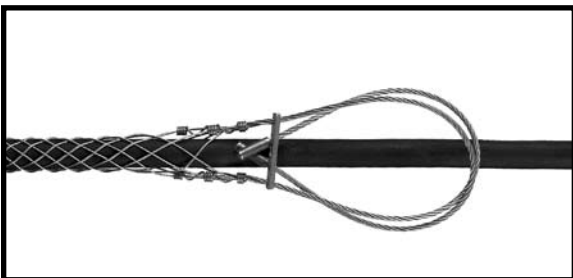

7304-009	.22-	.32	BD-022-UB	350 LBS.	9 3 1/2**
7304-010	.30-	.43	BD-030-UB	450 LBS.	10 4
7304-011	.41-	.56	BD-041-UB	550 LBS.	12 4 3/4
7304-012	.53-	.73	BD-053-UB	1000 LBS.	13 6
7304-013	.70-	.85	BD-070-UB	1400 LBS.	13 6 3/4
7304-014	.82-	1.00	BD-082-UB	1400 LBS.	14 8
7304-015	.96-	1.25	BD-096-UB	1500 LBS.	15 9 1/2

c  US LISTED 4D55

**DRY LOCATION ONLY**

## BUS DROP SAFETY SPRINGS

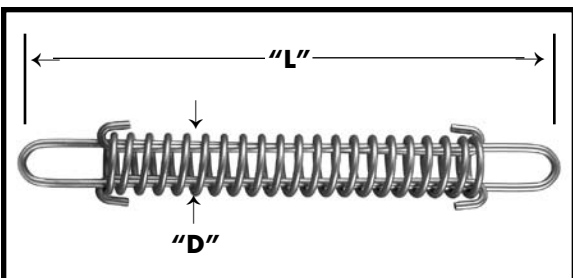

PART NUMBER	MAXIMUM DEFLECTION	DESCRIPTION	APPROX. BREAKING STRENGTH	LENGTH (NO LOAD) L D
203-02-001	2 1/8 @40 LBS.	40 LB. SPRING	600 LBS.	8 1/4 3/4
203-02-002	3 1/8 @80 LBS.	80 LB. SPRING	850 LBS.	8 1/4 1

E = Eye Length M = Mesh Length at Nominal Diameter (Inches)

\* Dim with Bale Fully Extended  
\*\* Not UL Listed

**CAUTION: NEVER USE GRIPS TO APPROX. BREAKING STRENGTH. REFER TO PAGE "B" FOR SAFETY AND WORKING LOAD FACTORS.**



# AMTEC CORD GRIPS

- See page "32" for additional technical data.
- Consult factory for modified, special designs, and/or finishes.

## STRAIGHT CORD CONNECTORS

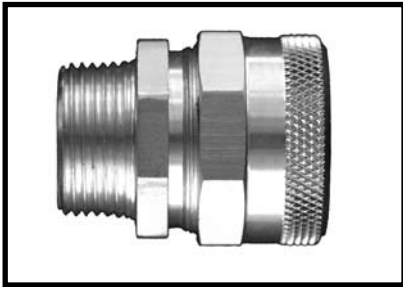

MACHINED ALUMINUM 1/4" - 1/2" NPT			
NPT HUB SIZE	DIAMETER RANGE	FORM SIZE	CATALOG NUMBER
	INCHES		
1/4"	.062 - .125	F1	CG12F1-1/4
	.125 - .187		CG18F1-1/4
	.187 - .250		CG25F1-1/4
	.250 - .312		CG31F1-1/4
	.312 - .375		CG37F1-1/4
	.375 - .437		CG43F1-1/4
3/8"	.062 - .125	F1	CG12F1-3/8
	.125 - .187		CG18F1-3/8
	.187 - .250		CG25F1-3/8
	.250 - .312		CG31F1-3/8
	.312 - .375		CG37F1-3/8
	.375 - .437		CG43F1-3/8
1/2"	.062 - .125	F1	CG12F1-1/2
	.125 - .187		CG18F1-1/2
	.187 - .250		CG25F1-1/2
	.250 - .312		CG31F1-1/2
	.312 - .375		CG37F1-1/2
	.375 - .437		CG43F1-1/2

## STRAIGHT CORD CONNECTORS

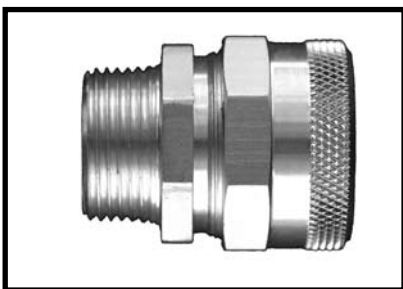

MACHINED ALUMINUM 1/2" - 3/4" NPT			
NPT HUB SIZE	DIAMETER RANGE	FORM SIZE	CATALOG NUMBER
	INCHES		
1/2"	.062 - .125	F2	CG12F2
	.125 - .187		CG18F2
	.187 - .250		CG25F2
	.250 - .375		CG37F2
	.312 - .437		CG43F2
	.375 - .500		CG50F2
	.500 - .625		CG32F2
1/2"	.375 - .500	F3	CG50F3-1/2
	.500 - .625		CG62F3-1/2
	.625 - .750		CG75F3-1/2
	.750 - .875		CG87F3-1/2
3/4"	.062 - .125	F2	CG12F2-3/4
	.125 - .187		CG18F2-3/4
	.187 - .250		CG25F2-3/4
	.250 - .375		CG37F2-3/4
	.312 - .437		CG43F2-3/4
	.375 - .500		CG50F2-3/4
.500 - .625	CG62F2-3/4		

**CAUTION: NEVER USE GRIPS TO APPROX. BREAKING STRENGTH. REFER TO PAGE "B" FOR SAFETY AND WORKING LOAD FACTORS.**

# AMTEC CORD GRIPS

- See page "32" for additional technical data.
- Consult factory for modified, special designs, and/or finishes.

## STRAIGHT CORD CONNECTORS

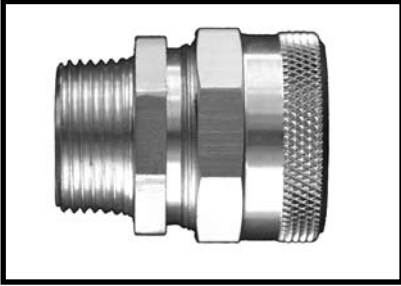

MACHINED ALUMINUM 3/4" - 1" NPT			
NPT HUB SIZE	DIAMETER RANGE	FORM SIZE	CATALOG NUMBER
	INCHES		
3/4"	.375 - .500	F3	CG50F3
	.500 - .625		CG62F3
	.625 - .750		CG75F3
	.750 - .875		CG87F3
1"	.375 - .500	F3	CG50F3-1
	.500 - .625		CG62F3-1
	.625 - .750		CG75F3-1
	.750 - .875		CG87F3-1
1"	.375 - .500	F4	CG50F4
	.500 - .625		CG62F4
	.625 - .750		CG75F4
	.750 - .875		CG87F4
	.875 - 1.00		CG100F4
1"	1.00 - 1.12	F5	CG112F4
	.750 - .875		CG87F5-1
	.875 - 1.00		CG100F5-1
	1.00 - 1.12		CG112F5-1
	1.12 - 1.25		CG125F5-1
	1.25 - 1.375		CG137F5-1
1"	1.375 - 1.437		CG143F5-1

## STRAIGHT CORD CONNECTORS

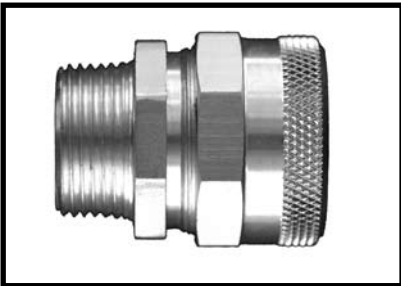

MACHINED ALUMINUM 1 1/4" - 1 1/2" NPT			
NPT HUB SIZE	DIAMETER RANGE	FORM SIZE	CATALOG NUMBER
	INCHES		
1 1/4"	.750 - .875	F5	CG87F5
	.875 - 1.00		CG100F5
	1.00 - 1.125		CG112F5
	1.125 - 1.250		CG125F5
	1.250 - 1.375		CG137F5
	1.375 - 1.437		CG143F5
1 1/2"	.750 - .875	F6	CG87F6
	.875 - 1.00		CG100F6
	1.00 - 1.125		CG112F6
	1.125 - 1.25		CG125F6
	1.25 - 1.375		CG137F6
1 1/2"	1.375 - 1.437		CG143F6
	1.250 - 1.375	F7	CG137F7-1-1/2
	1.375 - 1.500		CG150F7-1-1/2
	1.500 - 1.625		CG162F7-1-1/2
	1.625 - 1.750		CG175F7-1-1/2
1.750 - 1.875	CG187F7-1-1/2		

**CAUTION: NEVER USE GRIPS TO APPROX. BREAKING STRENGTH. REFER TO PAGE "B" FOR SAFETY AND WORKING LOAD FACTORS.**

# AMTEC CORD GRIPS

- See page "32" for additional technical data.
- Consult factory for modified, special designs, and/or finishes.

## STRAIGHT CORD CONNECTORS CASTINGS



ALUMINUM 2" - 3" NPT			
NPT HUB SIZE	DIAMETER RANGE	FORM SIZE	CATALOG NUMBER
	INCHES		
2"	1.250 - 1.375	F7	CG137F7
	1.375 - 1.500		CG150F7
	1.500 - 1.625		CG162F7
	1.625 - 1.750		CG175F7
	1.750 - 1.875		CG187F7
	1.875 - 1.937		CG197F7
	1.937 - 2.000		CG200F7
2"	1.688 - 1.812	F8	CG181F8-2
	1.812 - 1.937		CG193F8-2
	1.937 - 2.062		CG206F8-2
	2.062 - 2.188		CG218F8-2
	2.188 - 2.312		CG231F8-2
	2.312 - 2.437		CG243F8-2
2 1/2"	1.688 - 1.812	F8	CG181F8
	1.812 - 1.937		CG193F8
	1.937 - 2.062		CG206F8
	2.062 - 2.188		CG218F8
	2.188 - 2.312		CG231F8
	2.312 - 2.437		CG243F8
2 1/2"	2.437 - 2.625	F9	CG262F9-2 1/2
	2.625 - 2.812		CG281F9-2 1/2
	2.812 - 3.000		CG300F9-2 1/2
3"	1.688 - 1.812	F8	CG181F8-3
	1.812 - 1.937		CG193F8-3
	1.937 - 2.062		CG206F8-3
	2.062 - 2.188		CG218F8-3
	2.188 - 2.312		CG231F8-3
	2.312 - 2.437		CG243F8-3
3"	2.437 - 2.625	F9	CG262F9
	2.625 - 2.812		CG281F9
	2.812 - 3.000		CG300F9
	3.000 - 3.250		CG325F9

\*Cable jacket may have to be stripped to pass through connector.

**CAUTION: NEVER USE GRIPS TO APPROX. BREAKING STRENGTH. REFER TO PAGE "B" FOR SAFETY AND WORKING LOAD FACTORS.**

# AMTEC CORD GRIPS

- See page "32" for additional technical data.
- Consult factory for modified, special designs, and/or finishes.

## 90° MALE CORD CONNECTORS



ALUMINUM 3/8" - 1" NPT			
NPT HUB SIZE	DIAMETER RANGE	FORM SIZE	CATALOG NUMBER
	INCHES		
3/8"	.062 - .125	F1	NCG12F1
	.125 - .187		NCG18F1
	.187 - .250		NCG25F1
	.250 - .312		NCG31F1
	.312 - .375		NCG37F1
	.375 - .437		NCG43F1*
1/2"	.062 - .125	F2	NCG12F2
	.125 - .187		NCG18F2
	.187 - .250		NCG25F2
	.250 - .375		NCG37F2
	.312 - .437		NCG43F2
	.375 - .500		NCG50F2*
3/4"	.500 - .625	F3	NCG62F2*
	.375 - .500		NCG50F3
	.500 - .625		NCG62F3
	.625 - .750		NCG75F3*
1"	.750 - .875	F4	NCG87F3*
	.375 - .500		NCG50F4
	.500 - .625		NCG62F4
	.625 - .750		NCG75F4
	.750 - .875		NCG87F4
	.875 - 1.000		NCG100F4*
1.00 - 1.125	NCG112F4*		



\*Cable jacket may have to be stripped to pass through connector.

**CAUTION: NEVER USE GRIPS TO APPROX. BREAKING STRENGTH. REFER TO PAGE "B" FOR SAFETY AND WORKING LOAD FACTORS.**

# AMTEC CORD GRIPS

- See page "32" for additional technical data.
- Consult factory for modified, special designs, and/or finishes.

## 90° MALE CORD CONNECTORS



ALUMINUM 1 1/4" - 2" NPT			
NPT HUB SIZE	DIAMETER RANGE	FORM SIZE	CATALOG NUMBER
	INCHES		
1 1/4"	.750 - .875	F5	NCG87F5
	.875 - 1.000		NCG100F5
	1.000 - 1.125		NCG112F5
	1.125 - 1.250		NCG125F5*
	1.250 - 1.375		NCG137F5 *
	1.375 - 1.437		NCG143F5 *
1 1/2"	.750 - .875	F6	NCG87F6
	.875 - 1.000		NCG100F6
	1.000 - 1.125		NCG112F6
	1.125 - 1.250		NCG125F6
	1.250 - 1.375		NCG137F6
	1.375 - 1.437		NCG143F6
2"	1.250 - 1.375	F7	NCG137F7
	1.375 - 1.500		NCG150F7
	1.500 - 1.625		NCG162F7
	1.625 - 1.750		NCG175F7
	1.750 - 1.875		NCG187F7
	1.875 - 1.937		NCG193F7
	1.937 - 2.000		NCG200F7*



\*Cable jacket may have to be stripped to pass through connector.

**CAUTION: NEVER USE GRIPS TO APPROX. BREAKING STRENGTH. REFER TO PAGE "B" FOR SAFETY AND WORKING LOAD FACTORS.**

# AMTEC CORD GRIPS

- See page "32" for additional technical data.
- Consult factory for modified, special designs, and/or finishes.

## 45° MALE CORD CONNECTORS



ALUMINUM 1/2" - 1" NPT			
NPT HUB SIZE	DIAMETER RANGE	FORM SIZE	CATALOG NUMBER
	INCHES		
1/2"	.062 - .125	F2	VCG12F2
	.125 - .187		VCG18F2
	.187 - .250		VCG25F2
	.250 - .375		VCG37F2
	.312 - .437		VCG43F2
	.375 - .500		VCG50F2
3/4"	.500 - .625	F3	VCG62F2*
	.375 - .500		VCG50F3
	.500 - .625		VCG62F3
	.625 - .750		VCG75F3*
	.750 - .875		VCG87F3*
1"	.375 - .500	F4	VCG50F4
	.500 - .625		VCG62F4
	.625 - .750		VCG75F4
	.750 - .875		VCG87F4
	.875 - 1.00		VCG100F4*
	1.00 - 1.12		VCG112F4*

## 45° MALE CORD CONNECTORS



ALUMINUM 1 1/4" - 1 1/2" NPT			
NPT HUB SIZE	DIAMETER RANGE	FORM SIZE	CATALOG NUMBER
	INCHES		
1 1/4"	1.00 - 1.125	F5	VCG112F5
	1.125 - 1.250		VCG125F5
	1.250 - 1.375		VCG137F5*
	1.375 - 1.437		VCG143F5*
1 1/2"	1.00 - 1.125	F6	VCG112F6
	1.125 - 1.250		VCG125F6
	1.250 - 1.375		VCG137F6
	1.375 - 1.437		VCG143F6

\*Cable jacket may have to be stripped to pass through connector body.

**CAUTION: NEVER USE GRIPS TO APPROX. BREAKING STRENGTH. REFER TO PAGE "B" FOR SAFETY AND WORKING LOAD FACTORS.**



# AMTEC CORD GRIPS

- See page "32" for additional technical data.
- Consult factory for modified, special designs, and/or finishes.

## FEMALE CORD CONNECTORS



ALUMINUM 1 1/4" - 2" NPT			
NPT HUB SIZE	DIAMETER RANGE	FORM SIZE	CATALOG NUMBER
	INCHES		
3/8"	.062 - .125	F1	FCG12F1
	.125 - .187		FCG18F1
	.187 - .250		FCG25F1
	.250 - .312		FCG31F1
	.312 - .375		FCG37F1
	.375 - .437		FCG43F1 *
1/2"	.062 - .125	F2	FCG12F2
	.125 - .187		FCG18F2
	.187 - .250		FCG25F2
	.250 - .375		FCG37F2
	.312 - .437		FCG43F2
	.437 - .500		FCG50F2
3/4"	.500 - .625	F3	FCG62F2
	.375 - .500		FCG50F3
	.500 - .625		FCG62F3
	.625 - .750		FCG75F3
1"	.750 - .875	F4	FCG87F3 *
	.375 - .500		FCG50F4
	.500 - .625		FCG62F4
	.625 - .750		FCG75F4
	.750 - .875		FCG87F4
1"	.875 - 1.000	F4	FCG100F4
	1.00 - 1.112		FCG112F4 *



\*Cable jacket may have to be stripped to pass through connector.

**CAUTION: NEVER USE GRIPS TO APPROX. BREAKING STRENGTH. REFER TO PAGE "B" FOR SAFETY AND WORKING LOAD FACTORS.**

# AMTEC CORD GRIPS

- See page "32" for additional technical data.
- Consult factory for modified, special designs, and/or finishes.

## FEMALE CORD CONNECTORS



ALUMINUM 1 1/4" - 2" NPT			
NPT HUB SIZE	DIAMETER RANGE	FORM SIZE	CATALOG NUMBER
	INCHES		
1 1/4"	.750 - .875	F5	FCG87F5
	.875 - 1.000		FCG100F5
	1.000 - 1.125		FCG112F5
	1.125 - 1.250		FCG125F5
	1.250 - 1.375		FCG137F5*
	1.375 - 1.437		FCG143F5*
1 1/2"	.750 - .875	F6	FCG87F6
	.875 - 1.000		FCG100F6
	1.000 - 1.125		FCG112F6
	1.125 - 1.250		FCG125F6
	1.250 - 1.375		FCG137F6
	1.375 - 1.437		FCG143F6
2"	1.250 - 1.375	F7	FCG137F7
	1.375 - 1.500		FCG150F7
	1.500 - 1.625		FCG162F7
	1.625 - 1.750		FCG175F7
	1.750 - 1.875		FCG187F7
	1.875 - 1.937		FCG193F7
	1.937 - 2.000		FCG200F7

\*Cable jacket may have to be stripped to pass through connector body.

**CAUTION: NEVER USE GRIPS TO APPROX. BREAKING STRENGTH. REFER TO PAGE "B" FOR SAFETY AND WORKING LOAD FACTORS.**

# AMTEC CORD GRIPS TECHNICAL DATA

## CORD GRIPS & DELUXE CORD GRIPS

### FEATURES

- INDOOR AND OUTDOOR USE
- PREVENTS CORD PULL-OUT
- FOR USE WHERE CABLE IS EXPOSED TO MOISTURE OR SUBMERSION
- ELIMINATES FATIGUE POINTS
- CONTROL CABLE ARC-OF-BEND

### APPLICATIONS

- WIRING ENCLOSURES
- PUMPS
- COMPRESSORS
- CONSTRUCTION
- HAND TOOLS
- PROCESSING EQUIPMENT
- MATERIAL HANDLING EQUIPMENT
- MOTORS & MACHINE TOOLS

### COMPLIANCES:

National Electrical Code  
Articles 400-10 and 400-14  
NEMA standards FB1-1983  
Fed. Spec. W-C-586c  
Mil Spec 100 and 130

Suitable for use in hazardous locations under NEC Sec 501-4(b), 502-4(a)(2), and 503-2(a).  
For Class I, Div 2; Class II, Div 1 and 2; and Class III, Div 1 and 2.

### Note:

Special coatings on fittings are available upon request. Descriptions marked with an \* may have to have cable jacket stripped to pass through the bore of fitting.

### CORD GRIP MATERIALS

- ALUMINUM NUT
- ALUMINUM BODY
- NEOPRENE BUSHING

### DELUXE CORD GRIP MATERIALS

- ALUMINUM NUT
- ALUMINUM BODY
- NEOPRENE BUSHING
- SST MESH WITH ALUMINUM COLLARS

### AVAILABLE UPON REQUEST

- METAL CLAD SEALING "O" RING
- LOCKNUT
- SEE PG 33

**CAUTION: NEVER USE GRIPS TO APPROX. BREAKING STRENGTH. REFER TO PAGE "B" FOR SAFETY AND WORKING LOAD FACTORS.**

# AMTEC ACCESSORIES

- Sealing "O" Rings provide a liquid tight seal when fittings are installed in knockouts.
- The stainless steel retained "O" Ring is both moisture and oil resistant.

## METAL CLAD SEALING "O" RINGS



<u>CATALOG NUMBER</u>	<u>N.P.T. HUB SIZE</u>
205-09-009	3/8"
205-09-001	1/2"
205-09-002	3/4"
205-09-003	1"
205-09004	1 1/4"
205-09-005	1 1/2"
205-09-006	2"
205-09-007	2 1/2"
205-09-008	3"

## STANDARD CONDUIT LOCKNUTS ZINC PLATED STEEL



<u>CATALOG NUMBER</u>	<u>N.P.T. HUB SIZE</u>
323-13-001	3/8"
323-13-002	1/2"
323-13-003	3/4"
323-13-004	1"
323-13-005	1 1/4"
323-13-006	1 1/2"
323-13-008	2"
323-13-009	2 1/2"
323-13-0010	3"
323-13-0011	3 1/2"
323-13-0012	4"

**CAUTION: NEVER USE GRIPS TO APPROX. BREAKING STRENGTH. REFER TO PAGE "B" FOR SAFETY AND WORKING LOAD FACTORS.**

# AMTEC DELUXE CORD GRIPS

- Amtec Deluxe Cord Grips are used whenever cable or cord must withstand extreme applications and environmental conditions.
- Widely used with switch boxes, power duct cut-outs, drop stations, power hand tools, moving parts of machinery, pumps, compressors, and bus drop installations.
- Endless weave provides smooth cable-hugging ends for construction free installation.



THREAD SIZE N.P.T.	GRIP DIAM. RANGE INCHES	MALE THREAD DESCRIP.	90° MALE THREAD DESCRIP.	45° MALE THREAD DESCRIP.	FEMALE THREAD DESCRIP.
3/8"	.18-.25	DCG-25 F1	DCG-25 F1 90	DCG-25 F1 45	DCG-25 F1-F
	.25-.37	DCG-37 F1	DCG-37 F1 90	DCG-37 F1 45	DCG-37 F1-F
	.37-.43	DCG-43 F1	DCG-43 F1 90	DCG-43 F1 45	DCG-43 F1-F
1/2"	.18-.25	DCG-25 F2	DCG-25 F2 90	DCG-25 F2 45	DCG-25 F2-F
	.25-.37	DCG-37 F2	DCG-37 F2 90	DCG-37 F2 45	DCG-37 F2-F
	.31-.43	DCG-43 F2	DCG-43 F2 90	DCG-43 F2 45	DCG-43 F2-F
	.37-.50	DCG-50 F2	DCG-50 F2 90	DCG-50 F2 45	DCG-50 F2-F
	.50-.62	DCG-62 F2	DCG-62 F2 90	DCG-62 F2 45	DCG-62 F2-F
3/4"	.18-.25	DCG-25 F3	DCG-25 F3 90	DCG-25 F3 45	DCG-25 F3-F
	.25-.37	DCG-37 F3	DCG-37 F3 90	DCG-37 F3 45	DCG-37 F3-F
	.37-.50	DCG-50 F3	DCG-50 F3 90	DCG-50 F3 45	DCG-50 F3-F
	.50-.62	DCG-62 F3	DCG-62 F3 90	DCG-62 F3 45	DCG-62 F3-F
	.62-.75	DCG-75 F3	DCG-75 F3 90	DCG-75 F3 45	DCG-75 F3-F
1"	.37-.50	DCG-50 F4	DCG-50 F4 90	DCG-50 F4 45	DCG-50 F4-F
	.50-.62	DCG-62 F4	DCG-62 F4 90	DCG-62 F4 45	DCG-62 F4-F
	.62-.75	DCG-75 F4	DCG-75 F4 90	DCG-75 F4 45	DCG-75 F4-F
	.75-.87	DCG-87 F4	DCG-87 F4 90	DCG-87 F4 45	DCG-87 F4-F
	.87-1.00	DCG-100 F4	DCG-100 F4 90	DCG-100 F4 45	DCG-100 F4-F
1 1/4"	.75-.87	DCG-87 F5	DCG-87 F5 90	DCG-87 F5 45	DCG-87 F5-F
	.87-1.00	DCG-100 F5	DCG-100 F5 90	DCG-100 F5 45	DCG-100 F5-F
	1.00-1.125	DCG-112 F5	DCG-112 F5 90	DCG-112 F5 45	DCG-112 F5-F
	1.12-1.25	DCG-125 F5	DCG-125 F5 90	DCG-125 F5 45	DCG-125 F5-F
	1.25-1.37	DCG-137 F5	DCG-137 F5 90	DCG-137 F5 45	DCG-137 F5-F

**CAUTION: NEVER USE GRIPS TO APPROX. BREAKING STRENGTH. REFER TO PAGE "B" FOR SAFETY AND WORKING LOAD FACTORS.**

# AMTEC DELUXE CORD GRIPS



THREAD SIZE N.P.T.	GRIP DIAM. RANGE INCHES	MALE THREAD DESCRIP.	90° MALE THREAD DESCRIP.	45° MALE THREAD DESCRIP.	FEMALE THREAD DESCRIP.
1 1/2"	.75-.87	DCG-87 F6	DCG-87 F6 90	DCG-87 F6 45	DCG-87 F6-F
	.87-1.00	DCG-100 F6	DCG-100 F6 90	DCG-100 F6 45	DCG-100 F6-F
	1.00-1.125	DCG-112 F6	DCG-112 F6 90	DCG-112 F6 45	DCG-112 F6-F
	1.125-1.25	DCG-125 F6	DCG-125 F6 90	DCG-125 F6 45	DCG-125 F6-F
	1.25-1.37	DCG-137 F6	DCG-137 F6 90	DCG-137 F6 45	DCG-137 F6-F
	1.37-1.43	DCG-143 F6	DCG-143 F6 90	DCG-143 F6 45	DCG-143 F6-F
2"	1.20-1.375	DCG-137 F7	DCG-137 F7 90		
	1.375-1.500	DCG-150 F7	DCG-150 F7 90		
	1.500-1.625	DCG-162 F7	DCG-162 F7 90		
	1.625-1.750	DCG-175 F7	DCG-175 F7 90		
	1.750-1.875	DCG-187 F7	DCG-187 F7 90		
	1.875-1.937	DCG-193 F7	DCG-193 F7 90		
	1.937-2.000	DCG-200 F7	DCG-200 F7 90		
2 1/2"	1.687-1.812	DCG-181 F8			
	1.812-1.937	DCG-193 F8			
	1.937-2.062	DCG-206 F8			
	2.062-2.187	DCG-218 F8			
	2.187-2.312	DCG-231 F8			
	2.312-2.437	DCG-243 F8			
3"	2.437-2.625	DCG-262 F9			
	2.625-2.812	DCG-281 F9			
	2.812-3.000	DCG-300 F9			
	3.000-3.250	DCG-325 F9			

**CAUTION: NEVER USE GRIPS TO APPROX. BREAKING STRENGTH. REFER TO PAGE "B" FOR SAFETY AND WORKING LOAD FACTORS.**



# AMTEC BACKSHELL ADAPTERS

Applications: Amtec Backshell Adapters are devices for mating AN-MS Connectors and other connectors with straight threads. They eliminate the use of an adapter and incorporate all the features of an Amtec Deluxe Cord Grip. Amtec Backshell Adapters eliminate the need for the cord clamp nut on AN-MS Connectors when subjected to pull tensions, flexing, bending, twisting and vibration. Uses: Electrical Consoles, mobile equipment, and electrical terminations where plugs are used for connecting and disconnecting electrical circuits that require additional protection.



CABLE RANGE	AN-MS CONNECTOR	THREAD SIZE	FORM	AMTEC PART NO.
.18 - .25	8S, 10S	1/2" - 28	F1	DCG25A1000
.25 - .37				DCG37A1000
.37 - .43				DCG43A1000
.18 - .25	10SL, 12, 12S	5/8" - 24	F1	DCG25A1001
.25 - .37				DCG37A1001
.37 - .43				DCG43A1001
.18 - .25	14, 14S	3/4" - 20	F2	DCG25A1002
.25 - .37				DCG37A1002
.37 - .43				DCG43A1002
.43 - .50				DCG50A1002
.50 - .62				DCG62A1002
.43 - .50	11	13/16" - 20	F2	DCG50A1003
.18 - .25	16, 16S	7/8" - 20	F2	DCG25A1004
.25 - .37				DCG37A1004
.37 - .43				DCG43A1004
.43 - .50				DCG50A1004
.50 - .62				DCG62A1004
.18 - .25	18	1" - 20	F2	DCG25A1006
.25 - .37				DCG37A1006
.37 - .43				DCG43A1006
.43 - .50				DCG50A1006
.50 - .62				DCG62A1006
.25 - .37	20, 22	1 3/16" - 18	F3	DCG37A1008
.37 - .50				DCG50A1008
.50 - .62				DCG62A1008
.62 - .75				DCG75A1008
.75 - .87				DCG87A1008
.37 - .50	24, 28	1 7/16" - 18	F4	DCG50A1010
.50 - .62				DCG62A1010
.62 - .75				DCG75A1010
.75 - .87				DCG87A1010
.87 - 1.00				DCG100A1010

**CAUTION: NEVER USE GRIPS TO APPROX. BREAKING STRENGTH. REFER TO PAGE "B" FOR SAFETY AND WORKING LOAD FACTORS.**

# AMTEC BACKSHELL ADAPTERS



CABLE RANGE	AN-MS CONNECTOR	THREAD SIZE	FORM	AMTEC PART NO.	
.75 - .87	32	1 3/4" - 18	F5	DCG87A1012	
.87 - 1.00				DCG100A1012	
1.00 - 1.12				DCG112A1012	
1.12 - 1.25				DCG125A1012	
1.25 - 1.37				DCG137A1012	
1.37 - 1.43				DCG143A1012	
1.25 - 1.37	36	2" - 18	F7	DCG137A1016	
1.37 - 1.50				DCG150A1016	
1.50 - 1.62				DCG162A1016	
1.62 - 1.75				DCG175A1016	
1.75 - 1.87				DCG187A1016	
1.87 - 1.93				DCG193A1016	
1.93 - 2.00	DCG200A1016	40	2 1/4" - 16	F7-8	DCG187A1020
1.75 - 1.87	DCG193A1020				
1.87 - 1.93	DCG200A1020				
1.93 - 2.00	DCG218A1020				
2.06 - 2.18	DCG231A1020				
2.18 - 2.31	DCG243A1020				
2.31 - 2.43	44	2 1/2" - 16	F8	DCG181A1022	
1.68 - 1.81				DCG193A1022	
1.81 - 1.93				DCG206A1022	
1.93 - 2.06				DCG218A1022	
2.06 - 2.18				DCG231A1022	
2.18 - 2.31				DCG243A1022	
2.31 - 2.43	48	3" - 16	F8-9	DCG181A1024	
1.68 - 1.81				DCG193A1024	
1.81 - 1.93				DCG206A1024	
1.93 - 2.06				DCG218A1024	
2.06 - 2.18				DCG231A1024	
2.18 - 2.31				DCG243A1024	
2.31 - 2.43				DCG262A1024	
2.43 - 2.62				DCG281A1024	
2.62 - 2.81	DCG300A1024				
2.81 - 3.00					

**CAUTION: NEVER USE GRIPS TO APPROX. BREAKING STRENGTH. REFER TO PAGE "B" FOR SAFETY AND WORKING LOAD FACTORS.**

# AMTEC I - GRIPS

## I - GRIPS GALVANIZED

- Amtec I - Grips are easy to attach, will control cable-arc-of-bend, and provide heavy duty strain relief.
- Amtec I - Grips are made of high strength galvanized steel strand and are recommended for indoor use only.

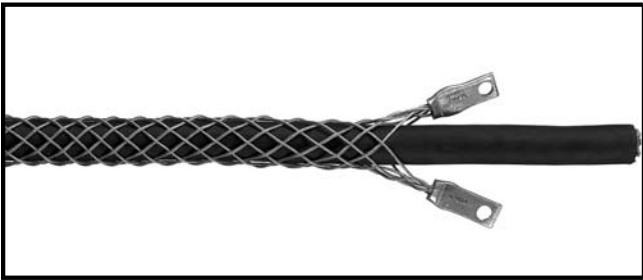

CATALOG NUMBER	DESCRIPTION	CABLE DIAMETER RANGE INCHES	E	M
7310-001	I-030	.30-.43	1.25	4
7310-002	I-040	.40-.56	1.25	4-3/4
7310-003	I-052	.52-.73	1.50	6
7310-004	I-070	.70-.85	1.50	6-1/2
7310-005	I-082	.82-1.00	1.50	8
7310-006	I-094	.94-1.25	1.50	10

## I - GRIPS NYLON COATED

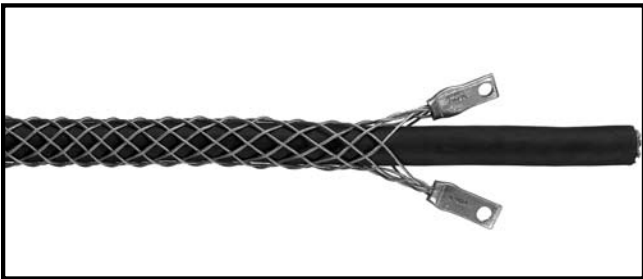

CATALOG NUMBER	DESCRIPTION	CABLE DIAMETER RANGE INCHES	E	M
7310-001N	I-030	.30-.43	1.25	4
7310-002N	I-040	.40-.56	1.25	4-3/4
7310-003N	I-052	.52-.73	1.50	6
7310-004N	I-070	.70-.85	1.50	6-1/2
7310-005N	I-082	.82-1.00	1.50	8
7310-006N	I-094	.94-1.25	1.50	10



E = Eye Length    M = Mesh Length at Nominal Diameter (Inches)

**CAUTION: NEVER USE GRIPS TO APPROX. BREAKING STRENGTH. REFER TO PAGE "B" FOR SAFETY AND WORKING LOAD FACTORS.**

# AMTEC SEALTITE GRIPS

Applications: Amtec Sealtite Conduit Grips are used in the wiring of machine tools, electrical enclosures, motors and systems where liquid-tight flexible conduit is subject to flexure, vibration, motion or strain.

## SEALTITE FITTING w/MESH NON-INSULATED



TRADE SIZE	STRAIGHT MALE	90°	45°
3/8"	STM-38	STM-38-90°	STM-38-45°
1/2"	STM-50	STM-50-90°	STM-50-45°
3/4"	STM-75	STM-75-90°	STM-75-45°
1"	STM-100	STM-100-90°	STM-100-45°
1 1/4"	STM-125	STM-125-90°	STM-125-45°
1 1/2"	STM-150	STM-150-90°	STM-150-45°
2"	STM-200	STM-200-90°	STM-200-45°

## SEALTITE FITTING w/MESH INSULATED



TRADE SIZE	STRAIGHT MALE	90°	45°
3/8"	STMI-38	STMI-38-90°	STMI-38-45°
1/2"	STMI-50	STMI-50-90°	STMI-50-45°
3/4"	STMI-75	STMI-75-90°	STMI-75-45°
1"	STMI-100	STMI-100-90°	STMI-100-45°
1 1/4"	STMI-125	STMI-125-90°	STMI-125-45°
1 1/2"	STMI-150	STMI-150-90°	STMI-150-45°
2"	STMI-200	STMI-200-90°	STMI-200-45°

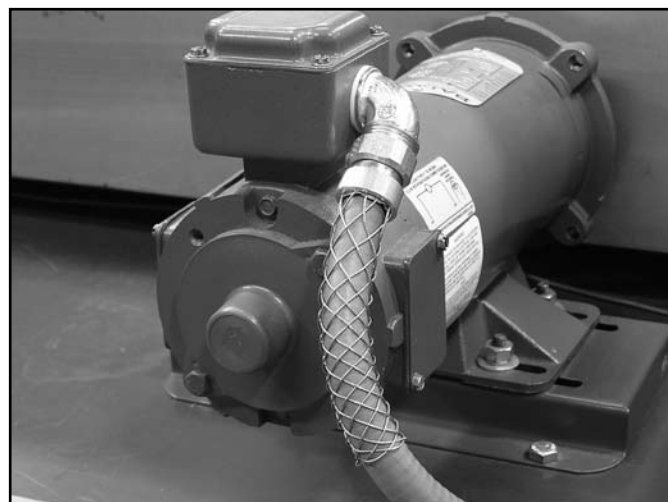

**CAUTION: NEVER USE GRIPS TO APPROX. BREAKING STRENGTH. REFER TO PAGE "B" FOR SAFETY AND WORKING LOAD FACTORS.**

# AMTEC ADAPTERS

- Amtec adapters can be used wherever straight thread connectors and AN-MS multiple pin connectors are subjected to pull tensions, flexing, bending, twisting, and vibration, allowing the use of Amtec Grips.
- Electrical consoles, mobile equipment, or electrical terminations where plugs are used for connecting and disconnecting electrical circuits require additional protection.

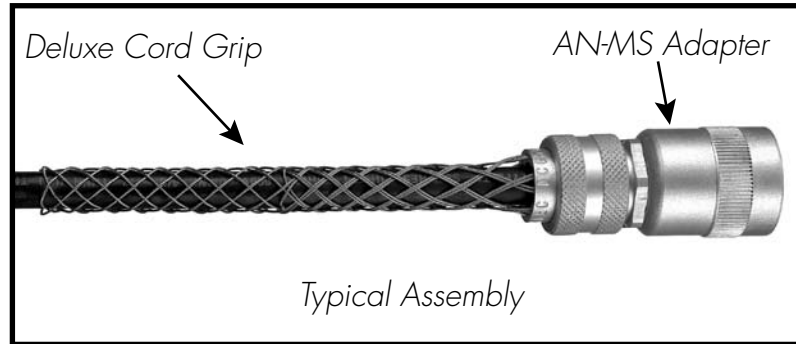

ADAPTER AND GRIP N.P.T. THREAD SIZE "B" INCHES	AN-MS CONNECTOR SIZE (no. stamped on connector shell)	AN-MS CABLE CLAMP NUMBER (no. stamped on clamp shell)	THREAD SIZE "A"	ADAPTER PART NUMBER
3/8	8S, 10S	3057-3	1/2 X 28	9104-1000
	10SL, 12, 12S	3057-4	5/8 X 24	9104-1001
	14, 14S	3057-6	3/4 X 20	9104-1002
1/2	14, 14S	3057-6	3/4 X 20	9104-1003
	16, 16S	3057-8	7/8 X 20	9104-1004
	18	3057-10	1 X 20	9104-1006
3/4	16, 16S	3057-8	7/8 X 20	9104-1005
	18	3057-10	1 X 20	9104-1007
	20, 22	3057-12	1-3/16 X 18	9104-1008
1	20, 22	3057-12	1-3/16 X 18	9104-1009
	24, 28	3057-16	1-7/16 X 18	9104-1010
	32	3057-20	1-3/4 X 18	9104-1012
	36	3057-24	2 X 18	9104-1015
1 1/4	24, 28	3057-16	1-7/16 X 18	9104-1011
	32	3057-20	1-3/4 X 18	9104-1013
	36	3057-24	2 X 18	9104-1016
1 1/2	32	3057-20	1-3/4 X 18	9104-1014
	36	3057-24	2 X 18	9104-1017
	40	3057-28	2-1/4 X 16	9104-1019
	44	3057-32	2-1/2 X 16	9104-1021
2	48	3057-40	3 X 16	9104-1023
	36	3057-24	2 X 18	9104-1018
	40	3057-28	2-1/4 X 16	9104-1020
	44	3057-32	2-1/2 X 16	9104-1022
	48	3057-40	3 X 16	9104-1024

**CAUTION: NEVER USE GRIPS TO APPROX. BREAKING STRENGTH. REFER TO PAGE "B" FOR SAFETY AND WORKING LOAD FACTORS.**

# AMTEC CONNECTOR GRIPS

## MILITARY APPLICATIONS:

- MS90561 - CONNECTOR GRIPS
- CRES-18-8 STAINLESS STEEL CONNECTOR GRIPS
- DFARS COMPLIANT MATERIAL
- CERTIFIED TO MIL-STD-790



## CUSTOM DESIGNED

### *Power & Control Cable Strain Relief*

- Use with all connector types, cord sets and assemblies to remove strain, vibration, flexure, or motion.
- Custom designed to mate with specially shaped or sized electrical connectors.
- Eliminates direct tension from terminal, thus removing strain from critical electrical connections.
- Connector grips extend the life of electrical systems and add safety.
- Stainless steel grips are corrosion free.
- Eliminate rigid fatigue points.
- Prevents pull tension, thus reducing cable pull out and system down time.
- Can be adapted to any connector including fiber optic cable.
- Collars available in aluminum or stainless steel.
- Multi-weave grip feature controls uniform arc or bend control.

**Caution: always refer to safety and working load factors.**

**CAUTION: NEVER USE GRIPS TO APPROX. BREAKING STRENGTH. REFER TO PAGE "B" FOR SAFETY AND WORKING LOAD FACTORS.**











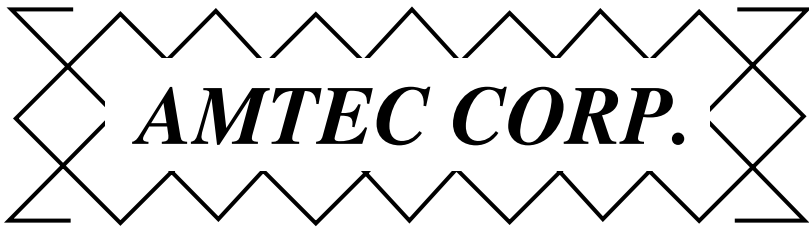

Represented by:

*MANUFACTURERS OF QUALITY WIRE MESH*

**30 Center Parkway • Plainfield, CT 06374**  
**800-893-8397 • [www.amtecgrips.com](http://www.amtecgrips.com)**

