

# 5269-C



UPC Code: 07847779531

Country of Origin: United States - \*Eligible for ARRA funded projects

NEMA: 5-15R



## Straight Blade Wiring Devices

### Brand Features

The Leviton line of Straight Blade Plugs and Connectors includes: Black & White® Industrial Grade devices that resist impact, corrosion and chemicals; Wetguard® for water or moisture resistance; Dustgard® for dust and dirt; Python™, with an innovative interlocking design; rugged nylon flanged and outlets; and integrated inlets and outlets with weather resistant covers.

### Item Description

15 Amp, 125 Volt, NEMA 5-15R, 2P, 3W, Connector, Straight Blade, Industrial Grade, Grounding - Black-White

### Technical Information

#### Electrical Specifications

**Grounding:** Grounding

**Amperage:** 15 Amp

**Voltage:** 125 Volt

**Pole:** 2

**Wire:** 3

**Temperature Rise:** Max 30C after 250 cycles OL at 200 percent rated current

**Dielectric Voltage:** Withstands 2000V per UL498

**Current Interrupting:** Certified for current interrupting at full rated current

#### Mechanical Specifications

**Terminal ID:** Brass-Hot, Green-Ground, Silver-Neutral

**Terminal Accom.:** 18-10 AWG

**Product ID:** Ratings and NEMA I.D. permanently marked on device

**Cord Range:** .245 - .700

#### Product Features

**NEMA:** 5-15R

**Color:** Black-White

#### Environmental Specifications

**Flammability:** Rated V-2 per UL94

**Operating Temperature:** -40C to 60C

#### Material Specifications

**Body Material:** Super Tough Nylon

**Back Cover:** Thermoplastic

**Wire Module:** Nylon

**Cord-Clamp:** Nylon

**Clamp Insert:** Nylon

**Blades/Contacts:** Solid Brass

**Terminal Screws:** Brass

**Assembly Screws:** Steel, Zinc Plated

**Color:** Black-White

#### Standards and Certifications

**NEMA:** WD-6

**ANSI:** C-73

**UL 498:** File E13399

**UL Fed Spec WC-596:** File E13393

**CSA C22.2 No. 42:** File LR-406

**NOM:** 057

**Warranty:** Lifetime Warranty

### Dimensional Diagram

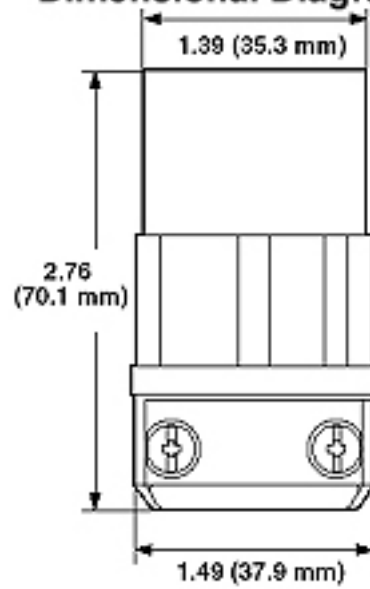

### Wiring Diagram

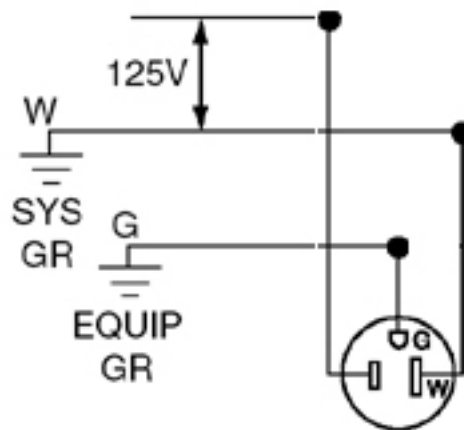

5-15R

### SPECIFICATION SUBMITTAL

JOB NAME: <input type="text"/>	CATALOG NUMBERS: <input type="text"/>	
JOB NUMBER: <input type="text"/>	<input type="text"/>	<input type="text"/>

**Leviton Manufacturing Co., Inc.**

201 North Service Road, Melville, NY 11747

Telephone: 1-800-323-8920 · FAX: 1-800-832-9538 · Tech Line (8:30AM-7:30PM E.S.T. Monday-Friday): 1-800-824-3005

**Leviton Manufacturing of Canada, Ltd.**

165 Hymus Boulevard, Pointe Claire, Quebec H9R 1E9 · Telephone: 1-800-469-7890 ·

FAX: 1-800-824-3005 · [www.leviton.com/canada](http://www.leviton.com/canada)

**Leviton S. de R.L. de C.V.**

Lago Tana 43, Mexico DF, Mexico CP 11290 · Tel.: (+52)55-5082-1040 · FAX: (+52)5386-1797 · [www.leviton.com.mx](http://www.leviton.com.mx)

**Visit our Website at: [www.leviton.com](http://www.leviton.com)**

© 2012 Leviton Manufacturing Co., Inc. All rights reserved. Subject to change without notice.



**Leviton has a global presence.**

If you would like to know where your local Leviton office is located please go to: [www.leviton.com/international/contacts/](http://www.leviton.com/international/contacts/)

*\*Buy American Compliant Logo -- The American Recovery And Reinvestment Act of 2009 ("ARRA") provides federal grants and loans for projects throughout the country. Section 1605 of the Act, named the "Buy American" provision, requires that certain materials and manufactured products used in projects funded by the Act be manufactured in the United States. The appearance of the Recovery Act Logo in relation to a Leviton product is only intended to reflect that such product may be used in an ARRA funded project. It does not mean that such product or Leviton is sponsored or endorsed by, or that Leviton receives funds from, the federal government or the Recovery Accountability and Transparency Board. Nothing in Leviton's use of the logo is intended to suggest anything regarding the requirements for funding under ARRA.*