

G



JAY R. SMITH MFG. CO.
 DIVISION OF SMITH INDUSTRIES, INC.
 POST OFFICE BOX 3237
 MONTGOMERY, ALABAMA 36109-0237 (USA)
 TEL: 334-277-8520 FAX: 334-272-7396 www.jrsmith.com



MEMBER OF:



LOCATION

DRAWING NUMBER
S1080SIZE
ASCALE:
NONEDATE:
8-19-83APPROVED BY:
JDCHECKED BY:
JDDRAWN BY:
CR

1080

WE CAN ASSUME NO RESPONSIBILITY FOR USE OF SUPERSEDED OR VOID DATA

DIMENSIONS ARE SUBJECT TO MANUFACTURERS TOLERANCE AND CHANGE WITHOUT NOTICE

SPECIAL PURPOSE ROOF DRAINS

WATER DAM TYPE

FUNCTION: Used in flat roofs of any construction where a constant height of water is desired on the roof. It may also be used as an emergency overflow for conventional roofs, draining rain water when the depth of the water on the roof reaches the water dam height.

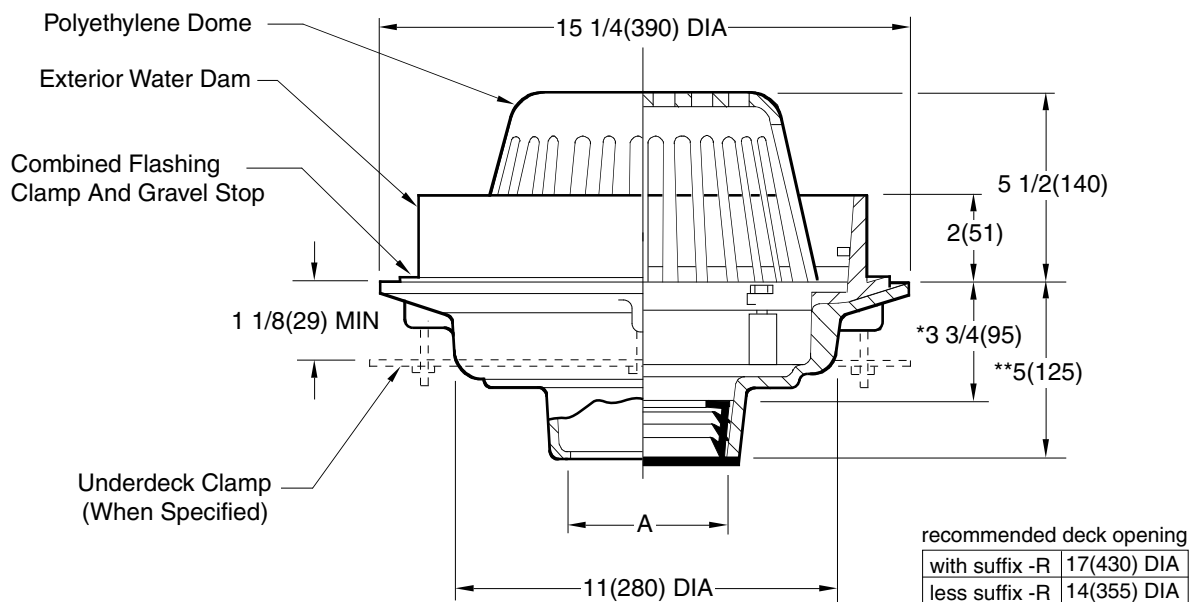

*This Dimension to Internal Stop of Speedi-Set Gasket

**Same for Caulk, NO-HUB and Speedi-Set. 3 3/4(95) for Threaded.

A (Pipe Size) 02(50), 03(75), 04(100), 05(125), 06(150) or 08(200)

Fig. 1080C CAULK OUTLET
 Fig. 1080Y NO-HUB OUTLET

REGULARLY FURNISHED:

Duco Cast Iron Body, Flashing Clamp and Gravel Stop with Polyethylene Dome, and Cast Iron Water Dam.

NOTE: Dimensions shown in parentheses are in millimeters.

VARIATIONS:

- Adjustable Extension(Specify Fig. 1045)
- Expansion Joint (Specify Fig. 1710)
- Extension -E (Specify Height)
- "L" Shaped Underdeck Clamp -CL
- L Speedi-Set Service Weight
02(50), 03(75) & 04(100)" sizes only
- LXH Speedi-Set Extra Heavy
02(50), 03(75) & 04(100)" sizes only
- Secondary Flashing Clamp -C2
- Sump Receiver -R
- Underdeck Clamp -C
- Vandal Proof Dome -U
- T Threaded Outlet

OPTIONAL MATERIALS:

- Aluminum Dome -AD
- Cast Iron Dome -CID
- Galvanized Cast Iron Body & Collar -G
- Galvanized Cast Iron Dome -CIDG
- Rough Bronze Dome -RBD

REV.	DATE	DESCRIPTION	BY	CKD. BY	WEIGHT POUNDS	VOLUME CUBIC FEET	FIGURE NUMBER
	07/20/05 5-26-99 7-2-96	Rev. Variations Rev. Opt. Mat. Added Millimeters	JJ CMD CMD	CL BS BS			1080