

Structural Brace Attachment Fig. AF087

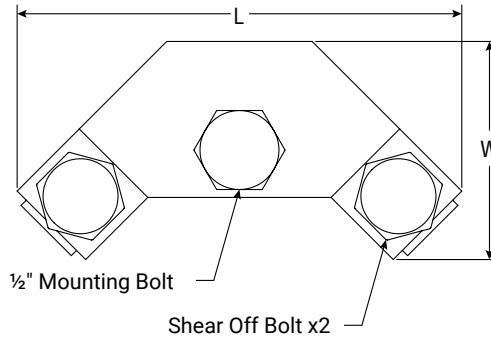
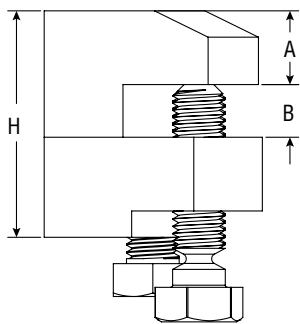

FIG. AF087 Dimensions and Weight

Mounting Bolt	A	B	L	W	H	Weight
	In./mm	In./mm	In./mm	In./mm	In./mm	
1/2" (M12)	0.75 19.1	0.50 12.7	4.25 108.0	2.00 50.8	2.13 54.0	2.00 0.91

Patent: No. 6,629,678

Notes:

ASC Engineered Solutions™ brand bracing components are designed to be compatible ONLY with other ASC Engineered Solutions brand bracing components, resulting in a Listed seismic bracing assembly. Updated UL listing information may be viewed at www.ul.com and updated FM approval information may be viewed at www.approvalguide.com.

Material Specifications

Size Range:

Flange Thickness: 1/8" - 1/2"

Material

Ductile Iron Casting with Carbon Steel Hardware

Finish

Plain

Electro-Galvanized per ASTM B633

Service

A seismic structural attachment designed to attach to steel I-beams, flanges, and joists. The AF087 rigidly braces piping systems subjected to horizontal and vertical seismic loads. The Af087 is also UL listed as an upper hanger attachment for up to 6" pipe at maximum allowed hanger spacing.

Approvals

cULus Listed (ANSI/UL 203a) and FM Approved (FM 1950-13). Complies with NFPA 13, ASCE 7, IBC, & MSS SP-127 bracing requirements. UL 203 Listed as a hanger attachment.

Features

The set screw provides a visual indication that proper installation has been achieved.

Ordering

Specify figure number, finish, and description.

Disclaimer:

ASC Engineered Solutions does not provide any warranties and specifically disclaims any liability whatsoever with respect to ASC bracing products and components that are used in combination with products, parts or systems not manufactured or sold by ASC. In no event shall ASC be liable for any incidental, direct, consequential, special or indirect damages or lost profits where non-ASC bracing components have been, or are used.

Seis Brace® Seismic Fire Protection Design Tool may be accessed at www.seisbrace.com



PROJECT INFORMATION	APPROVAL STAMP
Project:	Approved
Address:	Approved as noted
Contractor:	Not approved
Engineer:	Remarks:
Submittal Date:	
Notes 1:	
Notes 2:	

Structural Brace Attachment

Fig. AF087

FIG. AF087 cULus Listing per ANSI/UL 203a (ASD)

Structure	Load Orientation	Flange Thickness	Swivel	Horizontal Load Rating at Brace Angle			
				30°-44°	45°-59°	60°-90°	Listed
Horizontal Steel Flange and Vertical Steel Flange	Parallel to Flange and Perpendicular to Flange	0.1875-0.500 in (4.75-12.70 mm)	AF076	685 lbf (3.05 kN)	968 lbf (4.31 kN)	1186 lbf (5.28 kN)	1370 lbf (6.09 kN)
			AF075	477 lbf (2.12 kN)	674 lbf (3.00 kN)	825 lbf (3.67 kN)	954 lbf (4.24 kN)
			AF077				

- 1) Listed for installation with Fig. AF075, AF076, and AF077. The lowest load rating at angle shall control the load rating of the assembly.
- 2) Brace Angles are determined from Vertical.
- 3) Listed load ratings reduced for angle ranges in accordance with NFPA 13-2019 Table 18.5.2.3.
- 4) Minimum safety factor of 2.2 in accordance with NFPA 13-2019 Section A.18.5.2.3.

FIG. AF087 ccULus Listing per UL 203a (ASD) for NFPA 13-2016 Editions or Earlier

Structure	Load Orientation	Flange Thickness	Horizontal Load Rating at Brace Angle			
			30°-44°	45°-59°	60°-90°	Listed
Horizontal Steel Flange and Vertical Steel Flange	Parallel to Flange and Perpendicular to Flange	0.1875-0.500 in (4.75-12.70 mm)	700 lbf (3.11 kN)	990 lbf (4.40 kN)	1212 lbf (5.39 kN)	1400 lbf (6.23 kN)

- 1) Listed for installation with Fig. AF075, AF076, and AF077. The lowest load rating at angle shall control the load rating of the assembly.
- 2) Brace Angles are determined from Vertical.
- 3) Listed load ratings reduced for angle ranges in accordance with NFPA 13-2016 Table 9.3.5.2.3.
- 4) Minimum safety factor of 1.5 in accordance with NFPA 13-2016 Section A.9.3.5.2.3.
- 5) The AF087 is not FM Approved to attach to a Horizontal Steel Flange. For an FM Approved solution for attaching a sway brace to a horizontal steel flange (I-beam) use the Fig. AF720 or Fig. AF778.

FIG. AF087 FM Approved (Listing) per FM 1950-13 (ASD)

Structure	Load Orientation	Flange Thickness	Horizontal Load Rating at Brace Angle			
			30°-44°	45°-59°	60°-74°	75°-90°
Vertical Steel Flange	Parallel to Flange	0.125-0.500 in (6.35-31.75 mm)	1270 lbf (5.65 kN)	1740 lbf (7.74 kN)	2140 lbf (9.52 kN)	2380 lbf (10.59 kN)
	Perpendicular to Flange		1150 lbf (5.12 kN)	1630 lbf (7.25 kN)	3230 lbf (14.37 kN)	3610 lbf (16.06 kN)

- 1) Listed for installation with Fig. AF075, AF076, or AF077.
- 2) Brace Angles are determined from Vertical.
- 3) Minimum safety factor of 1.5 in accordance with NFPA 13-2016 Section A.9.3.5.2.3. To convert the load ratings above to a safety factor of 2.2 per NFPA 13-2019 Section A.18.5.2.3, multiply load ratings by a factor of 0.68.
- 4) To convert to LRFD Load Ratings, ASD Load Ratings may be multiplied by a factor of 1.5.

Installation

- 1 Place the AF087 on a horizontal or vertical steel flange.
- 2 Hand tighten the set screws until they contact the flange. Continue to torque the set screws until the heads break off.
- 3 Mount the AF075, AF076, or AF077 to the 1/2" mounting bolt. The mounting bolt shall be installed wrench tight (typically finger tight plus 1/4 to 1/2 turns)

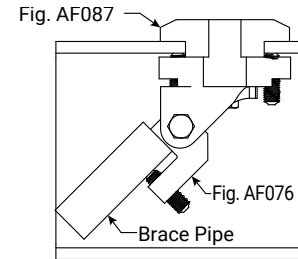

**Horizontal Steel Flange
Seismic Load Parallel to Flange**

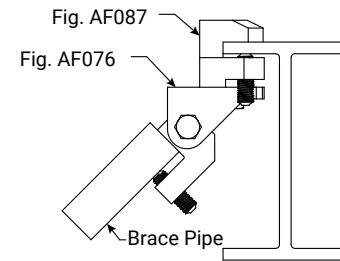

**Horizontal Steel Flange
Seismic Load Perpendicular to Flange**

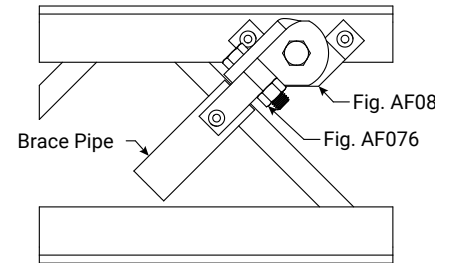

**Vertical Steel Flange
Seismic Load Parallel to Flange**

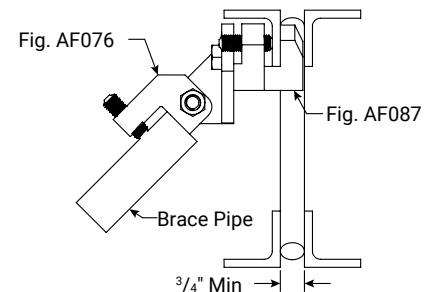

**Vertical Steel Flange
Seismic Load Perpendicular to Flange**



asc-es.com

Building connections that last™