

FEATURES

- Direct Spark Ignition (DSI) control board
- Microprocessor-based
- Controls inducer motors, air cleaner (if equipped), humidifier (if equipped), spark ignitor and the gas valve
- Monitors timing, trial for ignition, system switches, flame sensing and lockout
- 100% lockout safety feature
- Compatible with LP or Natural Gas
- LED indication for status and fault codes to aid in troubleshooting
- Replaces: Rheem 62-24140-04

SPECIFICATIONS

- **Control voltage:** 24 VAC (18-30 VAC), 60 Hz
- **Line voltage:** 115 VAC, 60 Hz
- **Power consumption:** 0.3A plus gas valve current at 24 VAC
- **Operating temperature:** -40°C (-40°F) to 75°C (176°F)

Timing

- **Pre-purge:** 30 seconds
- **Trial for ignition:** 7 seconds
- **Retries:** Two groups of two, 30 seconds delay within the group and 3 minutes delay between groups
- **Lockout:** 1 hour
- **Post-purge:** 90, 120, 160 and 180 seconds

Inputs

- **Power:** 24 VAC and COM
- **Thermostat interface:** R, W, Y and G
- **System switches:** Vent Pressure and Limit switches (Main and Over-temperature switches in series)
- **Flame Sensing**
- **Heat blower OFF delay miniature slide switch set**

Outputs

- **Spark**
- **Gas Valve:** GV
- **Inducer draft motor:** IDM
- **Blower motor:** FAN, COOL and HEAT speeds
- **Electric Air Cleaner:** EAC
- **Humidifier relay:** HUM
- **Heat/Cool relay:** H/C

LED indicators

- **Power, green LED:** PWR
- **Status, green LED:** OK
- **Flame status, yellow LED:** FLAME

Safety Considerations

Only trained personnel should install or service heating equipment. When working with heating equipment, be sure to read and understand all precautions in the documentation, on labels, and on tags that accompany the equipment. Failure to follow all safety guidelines may result in damage to equipment, severe personal injury or death.

Introduction

The ICM292 DSI gas ignition control replaces the following Rheem model: 62-24140-04. The ICM292 has incorporated LED diagnostics to assist in troubleshooting. Fault code information can be found in this application guide. Please keep this application guide with the furnace installation manual for future reference.

Electrostatic Discharge (ESD) Precautions

CAUTION!

Use caution when installing and servicing the furnace to avoid and control electrostatic discharge; ESD can impact electronic components. These precautions must be followed to prevent electrostatic discharge from hand tools and personnel. Following the precautions will protect the control from ESD by discharging static electricity buildup to ground.

1. Disconnect all power to the furnace. Do not touch the control or the wiring prior to discharging your body's electrostatic charge to ground.
2. To ground yourself, touch your hand and tools to a clean, metal (unpainted) furnace surface near the control board.
3. Service the furnace after touching the chassis. Your body will recharge with static electricity as you shuffle your feet or move around, and you must reground yourself.
4. Reground yourself if you touch ungrounded items.
5. Before handling a new control, reground yourself; this will protect the control. Store used and new controls in separate containers before touching ungrounded objects.
6. ESD damage can also be prevented by using an ESD service kit.

Remove Existing Control

CAUTION!

To service control, and prior to disconnection, label all wires. Failure to do so may result in wiring errors that can cause dangerous operation.

1. Turn thermostat to OFF position or set it to the lowest possible setting.
 2. Turn OFF electrical supply to furnace.
 3. Turn OFF gas supply to furnace.
- * **CAUTION:** Failure to turn off gas and electric supplies can result in explosion, fire, death, or personal injury.
4. Remove furnace blower and control access doors.
 5. Disconnect thermostat wires and humidifier wires (if equipped with a humidifier).
 6. Disconnect line voltage, blower, electronic air cleaner wires (if equipped), and transformer wires.
 7. Remove screws and any other fasteners, and the old circuit board.
 8. Examine control and control box to check for water stains.
 9. Make repairs if any sources of water leakage are found. Be sure to check humidifiers, evaporator coils, and vent systems in the area of the control.

Install New Control

1. Ground yourself. When handling circuit board, hold it by the edges.
2. Fasten circuit board with retaining screws.
3. Connect all line voltage, low voltage, and accessory wires.
4. Verify the sequence of operation.

Sequence of Operation

A W call from the thermostat will engage the Inducer Draft motor. The Vent Pressure switch closes. Ignition sequence begins, gas valve and spark are engaged, providing that system safety switches (Main and Over-temperature switches in series) are closed. The Blower motor will engage at HEAT speed 20 seconds after flame is established and sensed. On W call satisfaction the Inducer motor turns off after 10 seconds and Blower motor turns off according to Heat Blower Off delay setting.

A G call from the thermostat will engage Blower motor without delay at FAN speed. It disengages without delay when G call is removed.

A Y call from the thermostat will engage Blower motor without delay at COOL speed. It disengages 45 seconds after Y call is satisfied.

Troubleshooting Tips

Flame not established

1. If flame is not established during the 7 second initial sequence then the control will start the next trial for ignition in 30 seconds.
2. There will be two more attempts to ignite after 3 minute delay, 30 seconds apart before the respective fault code is triggered and ignition trials are stopped.
3. The gas valve is energized only during the ignition sequence of 7 seconds.
4. Blower motor is off until flame is established and 20 seconds later.

Flame out

1. Flame out is considered when flame is lost during heating.
2. When W signal is present and flame is sensed out then gas valve will disengage until the next trial for ignition
3. If flame is not established on the immediate sequence (2 above) then the control will continue with additional trials for ignition
4. Inducer and Blower motors will continue running during flame out scenario

Flame out of sequence

1. Flame out of sequence represents a scenario when flame is sensed while W signal is not present.
2. Inducer and Blower motors will be engaged (if not already running) right away and keep running for as long as the fault condition is present.
3. There is 1 hour lockout before a W call can be executed or on power reset

LED Fault Codes

# Of Flashes represents (Constant ON Normal operation)	Results
1	1 hour lockout due to flame out of sequence or didn't ignite after the fourth trial
2	Vent damper does not close within 10 seconds of W call
3	Limit switch is open
4	Vent damper switch is found closed on W call

Typical Wiring Diagram

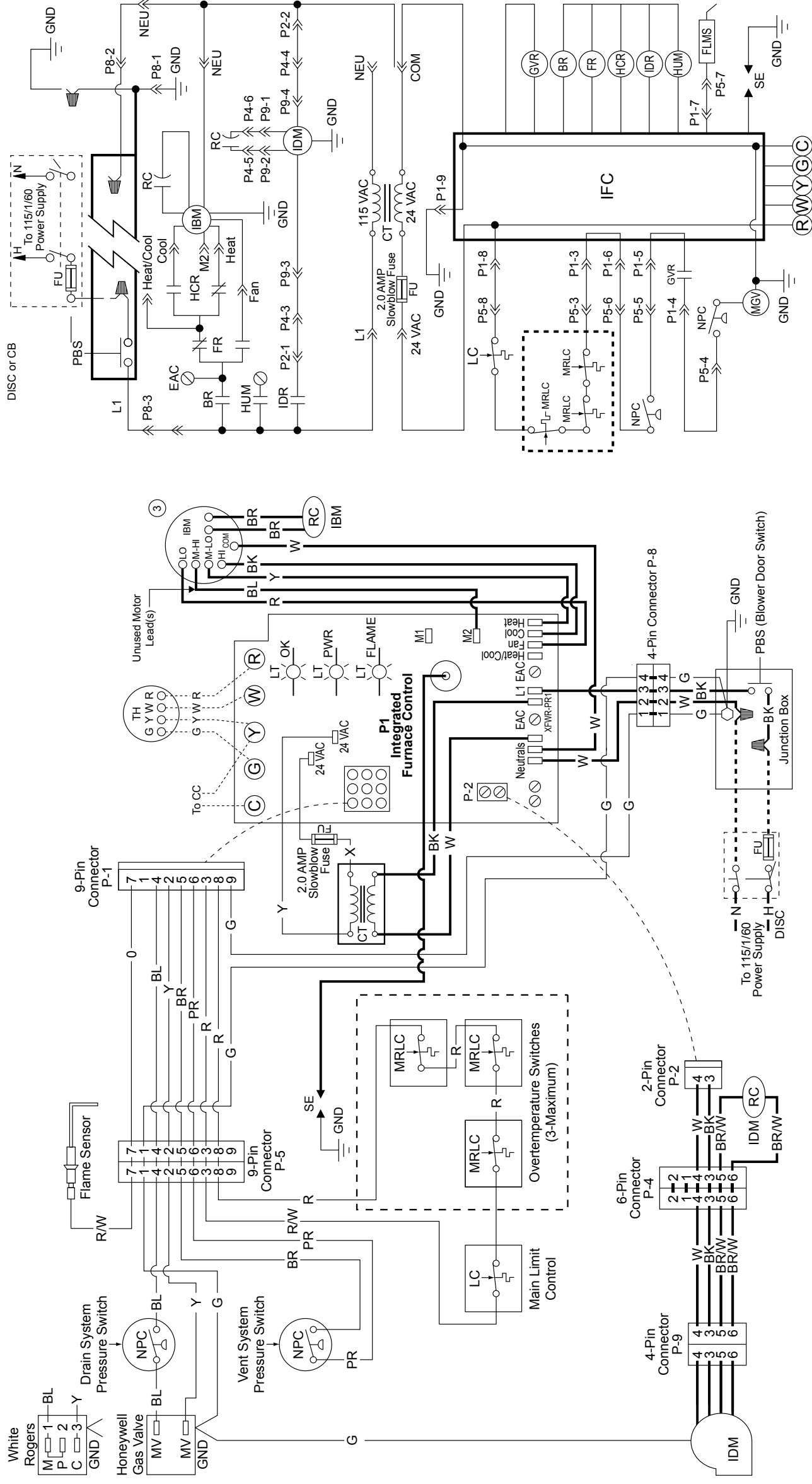

Legend:

ALC	Aux. Limit Control (Temp)	IDR	Indoor Draft Relay
BR	Blower Relay	IFC	Integrated Furnace Control
CC	Compressor Contactor	IR	Ignition Relay
CT	Control Transformer	LC	Limit Control
DISC	Disconnect Switch	MGV	Main Gas Valve
EAC	Electric Air Cleaner	MRLC	Main Reset Limit Control
FR	Fan Relay	MV	Main Valve
FLMS	Flame Sensor	NPC	Negative Pressure Control
FU	Fuse	PBS	Push Button Switch
GND	Ground	PL	Plug
GVR	Gas Valve Relay	RC	Run Capacitor
HCR	Heat/Cool Relay	SE	Spark Ignition Electrode
HUM	Humidifier Relay	TH	Thermostat (H/C)
IBM	Indoor Blower Motor		Wire Nut
IDM	Indoor Draft Motor		

Notes:

- If factory wiring of heating and cooling speeds is not desirable, refer to specifications section for appropriate speeds.
- Connect unused motor leads to M1 and/or M2.
- Models with 3 speed motors;
 - Blue lead is for medium speed
 - No yellow lead on motor

Wiring Information:

- LINE VOLTAGE**
- Factory standard
 - Factory Option
 - Field Installed
- LOW VOLTAGE**
- Factory standard
 - Factory Option
 - Field Installed

REPLACEMENT WIRE

- Must be the same size and type of insulation as original (105 C*Min.)

WARNING

- Cabinet must be permanently grounded and conform to I.E.C., N.E.C., C.E.C., and local codes

Wire Color Codes:

BK	Black	O	Orange
BR	Brown	PR	Purple
BL	Blue	R	Red
G	Green	W	White
GY	Gray	Y	Yellow

Electrical Wiring Diagram:

- Upflow Blower Induced Draft
- Gas Fired Forced Air Furnace
- Single Stage Heat
- Single Stage Cool
- Direct Spark Ignition