



The Pivotrol® Pump Patented PTC Pressure Powered Pump

Description

The Spirax Sarco **Pivotrol® Pump** (patented) is a non electric pump which transfers high temperature condensate, or other liquids from a low point, low pressure or vacuum space to an area of higher pressure or elevation. This self-contained unit including **PowerPivot®** technology (patented) uses steam, compressed air or any other suitable pressurized gas as the pumping force. **The standard Pivotrol® Pump (patented) will handle liquids from 0.9 to 1.0 specific gravity.**

Model	PTC	PTC-T-bone
PMO	200 psig (13.8 barg)	
Sizes	2" x 2" (DN50xDN50) 3" x 2" (DN80xDN50)	3" x 3"
Connections	Cover: NPT Liquid: ANSI 150/NPT	
Construction	Ductile Iron	
Warranty	3 million cycles or 5-year warranty, whichever number is achieved first. Lifetime warranty on spring	
Options	Pump modified to handle liquids down to 0.65 specific gravity	

Accessories

- Gauge glass with brass cocks.
- Reflex type gauge glass -Insulation cover.

Capacities

For sizing and selection data, see TI-5-030-US

Compliance

The product fully complies with the requirements of the European Pressure Equipment Directive 2014/68/EU and carries the **CE** mark when so required (must be specified at the time of order).

Operating Characteristics

Pump discharge per cycle.....7.1 gal (27.0 l) *Nominal*
 Average instantaneous discharge rate.....See TI-5-030-US
 Steam.....3 lbs (1.4 kg) per 1000 lbs (453.5 kg) of liquid pumped
 Air Consumption.....60 scf per 1000 lbs (453.5kg) of liquid pumped

For increased service life – Operate pump with motive pressure 15-20 psig (1.0 -1.4 barg) above pump back pressure.

Construction Materials

No.	Part	Material	Spec
1	Body	Ductile Iron	ASTM A395
2	Cover	Ductile Iron	ASTM A395
3	Cover Gasket	Grafoil	
4	Steam Inlet Valve Assembly	Stainless Steel	
5	Steam Inlet Valve Gasket	Stainless Steel	
6	Exhaust Valve Assembly	Stainless Steel	
7	Exhaust Valve Gasket	Stainless Steel	
8	Baffle	Stainless Steel	
9	Push Rod Assembly	Stainless Steel	
10	Mechanism Support	Stainless Steel	
11	Bushing Mounting Plate (Bushings)	Stainless Steel Carbide	
12	Spring Anchor	Carbide	
13	Spring	Inconel	
14	Float Arm Assembly (Pivots)	Stainless Steel Carbide	
15	Float Pivot	Stainless Steel	
16	Pin	Stainless Steel	
17	Paddle	Stainless Steel	
18	Float	Stainless Steel	
19	Screws (typical)	Stainless Steel	
20	Plugs (typical)	Forged Steel	
21	Check Valves (SDCV44)	Stainless Steel (see TI-7-224-US)	
22	Cycle Counter	Various (see TI-5-020-US)	

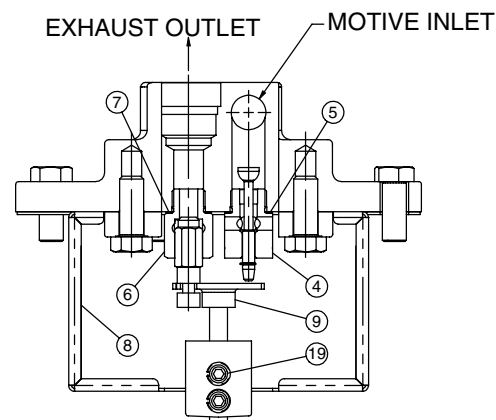
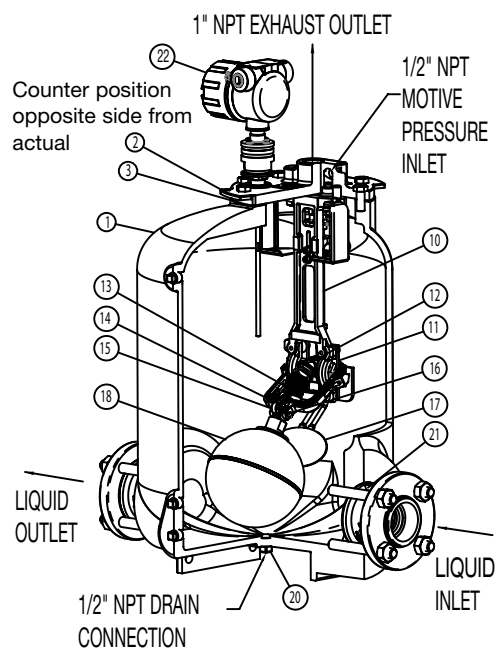

Local regulation may restrict the use of this product below the conditions quoted. Limiting conditions refer to standard connections only.
 In the interests of development and improvement of the product, we reserve the right to change the specification.

The Pivotrol® Pump Patented PTC Pressure Powered Pump

Dimensions (nominal) in inches and millimeters

PTC Size	A	B	C	D	E	F	G	H*	I	J (Ref Only)	Pump Weight
2" (DN50) PTC w/Stn. Stl. Check Valves	23.3	11.3	14	24.9	5.1	4.5	3.9	24.2	6.1	31.6	260 lb 118 kg
3" (DN80) x 2" (DN50) PTC w/Stn. Stl. Check Valves	23.9	11.3	14	24.9	5.1	4.5	3.9	24.2	6.1	31.6	270 lb 122 kg

PTC w/T-Bone	A	B	C	D	E	F	G	H*	I	J (Ref Only)	Pump Weight
3" (DN80) x 3" (DN80) w/Stn. Stl. Check Valves	19.2	13.8	14	24.9	5.1	N/A	4.5	24.2	6.1	31.6	280 lb 127 kg

* H Dimension is to the centerline of the motive supply inlet.

Limiting Operating Conditions

PMO	200 psig (13.8 barg)
Max. Operating Pressure	
Minimum motive differential required:	5 psig (0.34 barg)

Filling Head Requirements	Filling Head	
	Above Pump Cover	From Base of Pump
Standard recommended	12" (305mm)	36.9" (951mm)
Max filling head	48" (1219mm)	72.9" (1852mm)
Min filling head	2x2 (DN50xDN50) -3" (-76mm)	21.9" (556mm)
	3x2 (DN80xDN50) -1" (-25mm)	23.9" (607mm)
T-Bone	3x3 (DN80xDN80) -1" (-25mm)	23.9" (607mm)
Max Number of Cycles per minute =	6	
Specific gravity of pumped liquid options =	0.9 to 1.0; 0.8 to 0.89; 0.65 to 0.79	

Note: See TI-5-020-US for cycle counter details

Pressure Shell Design Conditions

PMA	200 psig@400°F	(13.8 barg@204°C)
Max. allowable pressure		
TMA	400°F@200 psig	(204°C@13.8 barg)
Max. allowable temperature		

Sample Specification

The pump shall be Spirax Sarco Pivotrol® Pump (patented) operated by steam, compressed air or other pressurized gas to 200 psig (13.8 barg), which does not require any electrical energy. The pump shall have stainless steel, split disc check valves on the inlet and outlet connections. The pump shall contain Spirax Sarco PowerPivot® (patented) inside to ensure longevity and reliability of the pump. The Pivotrol® Pump (patented) shall include an Inconel spring with a lifetime warranty and be supplied with an integral cycle counter to monitor a 3 million cycle or 5 year warranty, whichever number is achieved first. When required the pump shall be supplied with a gauge glass and custom designed insulation jacket.

Installation

Full details are given in IM-5-201-US, which accompanies the product.

Maintenance

Complete installation and maintenance instructions are given in IMI-5-201-US which accompanies the product.

