

SPECIFICATIONS

FIGURE 420

BRASS BODY BALL VALVES



2-PC FULL PORT 600 WOG

FEATURES

- 600 WOG
- 150 WSP
- Full port
- Threaded NPT ends (ANSI B1.20.1)
- Forged brass body and endcap
- 100% Electronically tested in open and closed position at 80 PSI
- Meets MSS SP-110 standards
- FM & CSA approved (1/2"-2")
- Blow-out proof stem
- Adjustable packing
- Stocked configurations:
 - Locking handle (1/4"-2")
- Optional lock lever kit (1/4"-4")
- Optional stem extension kit (1/4"-4")
- Optional tee handle kit (1/4"-1")
- Optional oval handle kit (1/4"-2")
- Optional memory stop kit (1/4"-2")
- Optional stainless handle (1/4"-2")

NOT FOR USE AT OR BELOW GROUND LEVEL

Gas Approvals

- CSA Class 3371-10, CGA 3.16, 125 PSIG, -40°F-149°F (1/4"-4")
- CSA Class 3371-88, ANSI Z21.15/CSA9.1, 1/2 PSIG, 32°F-188.6°F (1/2"-4")
- CSA Class 3371-90, ASME B16.33/b16.38, 125 PSIG, -40°F-149°F (1/4"-4")
- CSA Class 3371-92, ASME B16.44, 5 PSIG, -40°F-149°F (1/2"-2")
- CSA Class 3371-94, ASME B16.33, 125 PSIG, -40°F-149°F (1/2"-4")
- CSA Class 3371-97, UL-125, 250 PSIG, -40°F-130°F (1/4"-3/8")
- UL Class YRPV, ANSI/UL-842, 250 PSIG, -20°F-125°F (1/4"-4")
- UL Class YSDT, ANSI/UL-125, 250 PSIG, -40°F-130°F (1/4"-4")



ACCESSORIES/OPTIONS

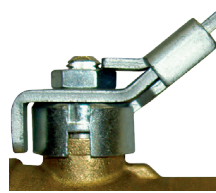

Locking Handle Kits



Tee Handle Kits



Stem Extension Kits



Memory Stops



Oval Handle Kits



Stainless Steel Handle

ADDITIONAL STOCKED CONFIGURATIONS



With Locking Lever (1/4"-2")

SPECIFICATIONS

FIGURE 420
BRASS BODY BALL VALVES



2-PC FULL PORT 600 WOG

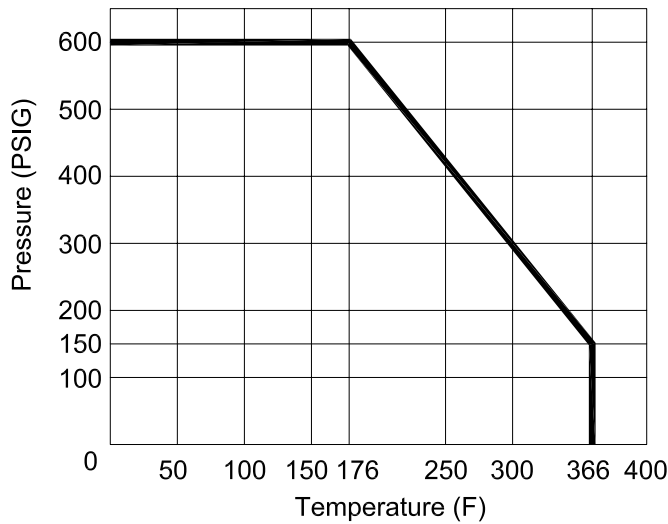

REFERENCE CHART

Size (in.)	Dimensions (in.)				
	ØP	E	L	H	H2
1/4	0.39	3.78	2.02	1.65	1.83
3/8	0.39	3.78	2.02	1.65	1.83
1/2	0.59	3.78	2.44	1.81	1.99
3/4	0.78	4.76	2.71	2.28	2.48
1	0.98	4.76	3.07	2.44	2.64
1-1/4	1.25	5.94	3.42	3.00	3.15
1-1/2	1.57	5.94	3.89	3.23	3.38
2	1.94	6.30	4.33	3.74	3.74
2-1/2	2.56	8.11	5.59	4.84	—
3	3.15	8.11	6.45	5.23	—
4	3.94	10.27	7.60	6.49	—

FIGURE NUMBER MATRIX

FNW 420		
CONFIGURATION	SIZE CODE (IN.)	
Standard Handle = Blank	1/4 = B	1-1/2 = J
Locking Handle = LL (1/4"–2")	3/8 = C	2 = K
	1/2 = D	2-1/2 = L
	3/4 = F	3 = M
	1 = G	4 = P
	1-1/4 = H	

KIT CODES

FNW 420	
KIT TYPE	SIZE CODE (IN.)
Locking Handle = LHK	1/4–1/2 = BD
Stem Extension = SE	3/4–1 = FG
Tee Handle = THK	1-1/4–1-1/2 = HJ
Oval Handle = OHK	2 = K
Memory Stop = MSK	2-1/2–4 = LM
Stainless Handle = SSHK	4 = P

CV & WEIGHTS

Size (in.)	Cv	Wt (lbs)
1/4	6	0.3
3/8	7	0.3
1/2	19	0.5
3/4	34	0.7
1	50	1.1
1-1/4	104	2.0
1-1/2	268	3.1
2	309	4.2
2-1/2	629	8.0
3	1018	12.9
4	1622	22.0

FIGURE 420

BRASS BODY BALL VALVES



2-PC FULL PORT 600 WOG

PARTS DIAGRAM

SIZES 1/4 TO 2 INCH

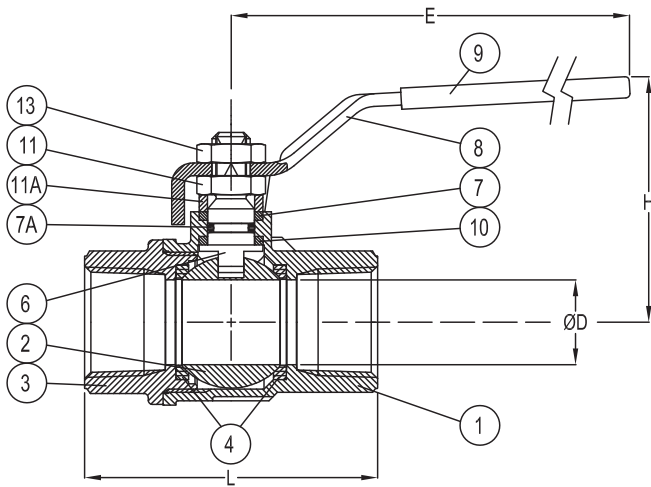

SIZES 2-1/2 TO 4 INCH

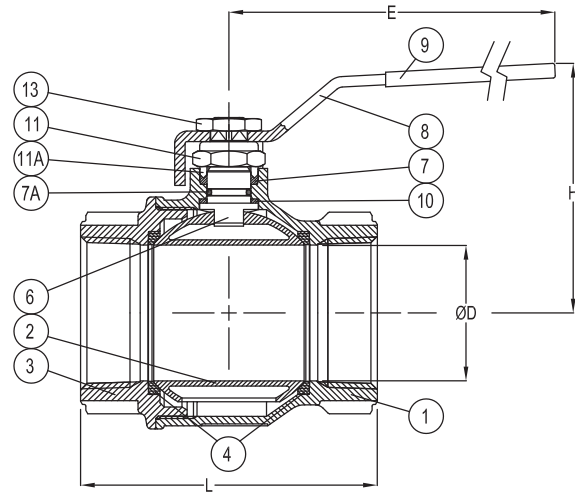

SIZES 1/4 TO 2 INCH WITH LOCKING LEVER

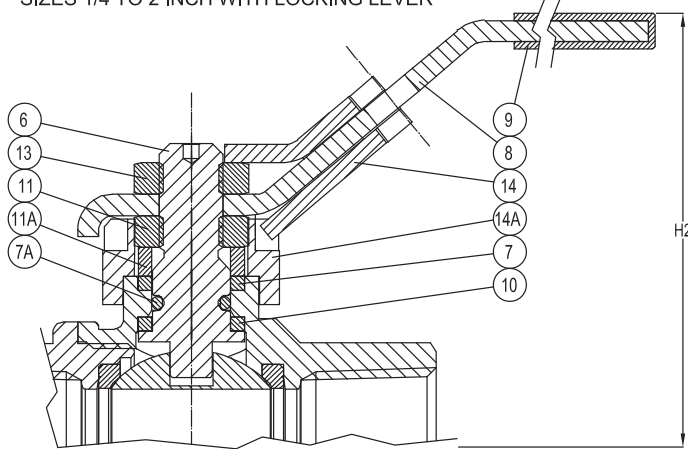

PART MATERIALS & QUANTITY

Ref #	Description	Material	Qty
1	Body	Brass CW 617N UNI EN 12165	1
2	Ball	Brass CW 617N UNI EN 12165 (Nickel-Chrome Plated)	1
3	End Cap	Brass CW 617N UNI EN 12165	1
4	Seat	PTFE	2
6	Stem	Brass CW 614N UNI EN 12164	1
7	Stem Packing	PTFE	1
7A	Stem O-Ring	NBR 75 Shore A	1
8	Handle	Fe P 11 UNI 5867	1
9	Handle Cover	Vinyl	1
10	Thrust Washer	PTFE	1
11	Gland Nut	Zinc Plated Steel 6S	1
11A	Packing Gland	Brass CW 614N UNI EN 12164	1
13	Handle Nut	Zinc Plated Steel 6S	1
14	Locking Pad	Fe P 11 UNI EN 10111	1
14A	Bushing	ZAMA G Zn A14 UNI EN1774	1