

DOMESTIC

NON-DOMESTIC

SUBMITTAL: C110 FLANGE JOINT CLASS 125 PRODUCT

(Current revisions for the noted Standards apply)

- SIZES:** 2" - 64" (Contact Tyler Union for 54" - 64" flange fitting information)
- STANDARDS:** ANSI/AWWA C110/A21.10, NFPA 13/24, ASME B16.1, 3" - 12" UL listed and FM approved
- MATERIAL:** Cast of ASTM A536 qualified ductile iron. Date code is cast on and required for traceability.
- PRESSURE RATING:** *Flanged fittings *2" - 48" rated at 250 psi. 54" - 64" rated at 150psi.
*Note: With rubber annular ring flange gasket, 2" - 24" flanged fittings can be rated at 350 psi.
- DEFLECTION:** Deflection is "not" recommended for flange joint due to the rigidity of the joint.
- NSF-61 & NSF372:** Meets all requirements including Annex G, Tyler Union's Underwriters Laboratory listing MH16439.
- COATING:** Asphaltic or Primer per ANSI/AWWA C104/A21.4, Standard primer is Tnemec Pota Pox N140-1211. Contact Tyler Union for additional coating options.
- CEMENT LINING:** Per ANSI/AWWA C104/A21.4, with double cement lining available upon request.
- EPOXY COATING:** Fusion bonded epoxy per ANSI/AWWA C116/A21.16. Additional coatings available upon request.
- BARE FITTINGS:** Available upon request.
- FLANGES:** ANSI Class 125 per ASME B16.1 and ANSI/AWWA C111/A21.11. Bolt holes shall straddle the center line
- NOTE: Class 125 ASME B16.1 are not compatible with Class 250 Flanges**
- NOTE: Class 250 ASME B16.1 fittings are available upon request.**
- FASTNERS:** High strength low alloy weathering steel per ANSI/AWWA C111/A21.11 and ASTM A242
- INSTALLATION:** Install per AWWA C600/C651 using pipe conforming to ANSI/AWWA C151/A21.51.

FLANGE DETAILS IN INCHES

BOLTS

Size Inches	Diameter DI Pipe	Flange O.D.	B.C. Diameter	Flange Thickness T	Bolt Hole Diameter	Size	Qty
2	2.51	6.00	4.75	0.62	0.750	5/8 x 2-1/4	4
3	3.96	7.50	6.00	0.75	0.750	5/8 x 2-1/4	4
4	4.80	9.00	7.50	0.94	0.750	5/8 x 3	8
6	6.90	11.00	9.50	1.00	0.875	3/4 x 3-1/2	8
8	9.05	13.50	11.75	1.12	0.875	3/4 x 3-1/2	8
10	11.10	16.00	14.25	1.19	1.000	7/8 x 4	12
12	13.20	19.00	17.00	1.25	1.000	7/8 x 4	12
14	15.30	21.00	18.75	1.38	1.125	1 x 4-1/2	12
16	17.40	23.50	21.25	1.44	1.125	1 x 4-1/2	16
18	19.50	25.00	22.75	1.56	1.250	1-1/8 x 5	16
20	21.60	27.50	25.00	1.69	1.250	1-1/8 x 5	20
24	25.80	32.00	29.50	1.88	1.375	1-1/4 x 5-1/2	20
30	32.00	38.75	36.00	2.12	1.375	1-1/4 x 5-1/2	28
36	38.30	46.00	42.75	2.38	1.625	1-1/2 x 7	32
42	44.50	53.00	49.50	2.62	1.625	1-1/2 x 7-1/2	36
48	50.80	59.50	56.00	2.75	1.625	1-1/2 x 8	44
54	Available on Request						
60	Available on Request						
64	Available on Request						

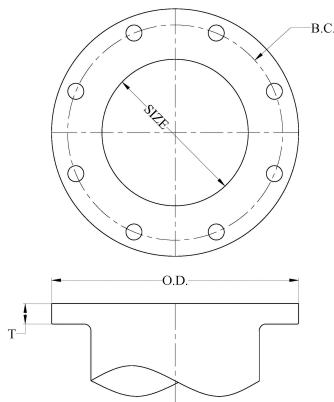

C110 DUCTILE IRON FULL BODY FITTINGS

SAMPLE SPECIFICATIONS

(Current ANSI/AWWA revisions apply)

Flanged fittings, 2” through 64”, shall be manufactured of Ductile Iron in accordance with all applicable terms and provisions of standards ANSI/AWWA C110/A21.10. Flange surfaces shall be faced and drilled in accordance with ANSI Class 125, B16.1. All Ductile Iron flanged fittings shall be rated for water pressure of 250 psi. Flanged ductile iron fittings in 24” (610 mm) and smaller sizes may be rated for 350 psi (2,413 kPa) with the use of special gaskets .

NOTE: Fittings are available prime coated, bare or epoxy coated. All coated fittings meet requirements of NSF-61, NSF-372 and Annex G. Interiors of fittings shall be lined and seal coated in accordance with ANSI/AWWA C104/A21.4. Installation of fittings shall be per AWWA C110.

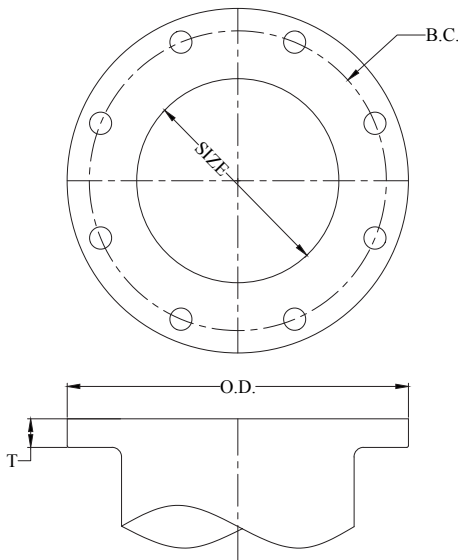

ANSI/AWWA C110 Class 125 Flange Fittings

FLANGE DETAILS						
Nominal Pipe Size Inch	Flange O.D.	B.C. Diameter	Flange Thickness T	Bolt Hole Diameter	Number of Bolts	Bolt Dia. and Lengths
2	6.00	4.75	0.62	0.750	4	5/8 x 2 1/4
3	7.50	6.00	0.75	0.750	4	5/8 x 2 1/2
4	9.00	7.50	0.94	0.750	8	5/8 x 3
6	11.00	9.50	1.00	0.880	8	3/4 x 3 1/2
8	13.50	11.75	1.12	0.880	8	3/4 x 3 1/2
10	16.00	14.25	1.19	1.000	12	7/8 x 4
12	19.00	17.00	1.25	1.000	12	7/8 x 4
14	21.00	18.75	1.38	1.130	12	1 x 4 1/2
16	23.50	21.25	1.44	1.130	16	1 x 4 1/2
18	25.00	22.75	1.56	1.250	16	1 1/8 x 5
20	27.50	25.00	1.69	1.250	20	1 1/8 x 5
24	32.00	29.50	1.88	1.375	20	1 1/4 x 5 1/2
30	38.75	36.00	2.12	1.375	28	1 1/4 x 6 1/2
36	46.00	42.75	2.38	1.625	32	1 1/2 x 7
42	53.00	49.50	2.62	1.625	36	1 1/2 x 7 1/2
48	59.50	56.00	2.75	1.625	44	1 1/2 x 8
54	66.25	62.75	3.00	2.00	44	1 3/4 x 8 1/2
60	73.00	69.25	3.12	2.00	52	1 3/4 x 9
64	80.00	76.00	3.38	2.00	52	1 3/4 x 9

Contact Tyler Union for 54”–64” flange fitting information.

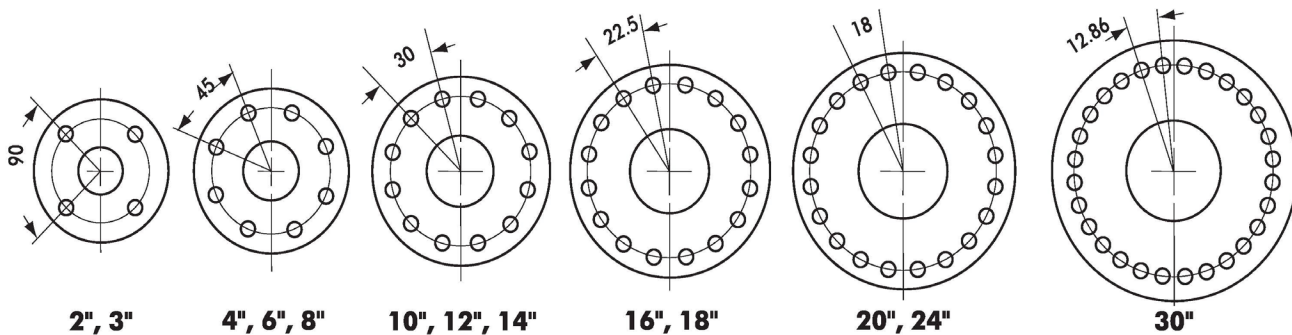

NOTE: Drilling templates are in multiples of four so that fittings may be made to face in any quarter. Bolt holes shall straddle the center line.

C110 DUCTILE IRON FULL BODY FITTINGS

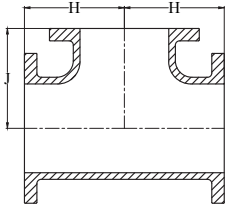

Straight Tees, Reducing on Branch Tees

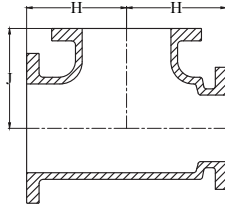

*Reducing on Run

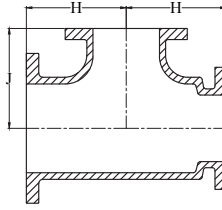

*Reducing on Run and Branch

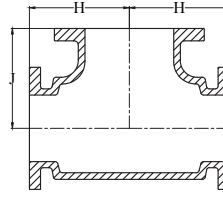

*Bullhead Tees

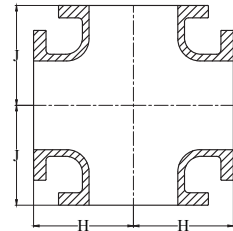

Straight and Reducing Crosses

TEES AND CROSSES									
Sizes					Domestic Weight		Import Weight		
Run	Run	Branch	H	J	Tee	Cross	Tee	Cross	
2	2	2	5.00	4.50	20	—	—	—	
3	3	2	5.50	5.50	35	—	—	—	
3	3	3	5.50	5.50	42	51	40	50	
4	4	2	6.50	5.50	53	—	—	—	
4	4	2	6.50	6.50	55	—	—	—	
4	4	3	6.50	6.50	54	76	60	70	
4	4	4	6.50	6.50	60	—	65	80	
4	4	6	8.00	8.00	88	—	—	—	
*6	4	4	8.00	8.00	85	—	—	—	
6	6	8	9.00	9.00	90	112	85	95	
6	6	4	8.00	8.00	90	141	90	110	
6	6	6	8.00	8.00	98	125	95	120	
*8	6	4	9.00	9.00	130	—	—	—	
*8	6	8	9.00	9.00	154	—	—	—	
8	8	3	9.00	9.00	128	140	—	—	
8	8	4	9.00	9.00	155	155	140	155	
8	8	6	9.00	9.00	148	172	145	165	
8	8	8	9.00	9.00	179	195	155	195	
*8	8	10	11.00	11.00	225	—	—	—	
*8	8	12	12.00	12.00	277	—	—	—	
*†10	6	6	13.00	13.00	278	—	—	—	
*†10	8	6	13.00	13.00	298	—	—	—	
*†10	8	8	13.00	13.00	278	—	—	—	
*†10	8	10	13.00	13.00	325	—	—	—	
10	10	4	11.00	11.00	239	220	205	220	
10	10	6	11.00	11.00	215	242	215	240	
10	10	8	11.00	11.00	254	294	225	265	
10	10	10	11.00	11.00	265	—	270	330	
10	10	12	12.00	12.00	337	—	—	—	
*†12	6	6	14.00	14.00	346	—	—	—	
*†12	6	8	14.00	14.00	362	—	—	—	
*†12	8	6	14.00	14.00	355	—	—	—	
*12	8	8	14.00	14.00	375	—	—	—	
*12	8	12	14.00	14.00	420	—	—	—	
*†12	10	6	14.00	14.00	390	—	—	—	
12	10	8	14.00	14.00	400	—	—	—	
12	10	10	14.00	14.00	420	—	—	—	
12	10	12	14.00	14.00	440	—	—	—	

* Not included in AWWA C110.

† H and J dimensions are two-inches longer than straight tees.

C110 DUCTILE IRON FULL BODY FITTINGS

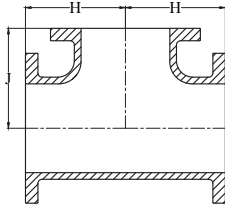

Straight Tees, Reducing on Branch Tees

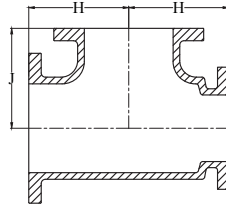

*Reducing on Run

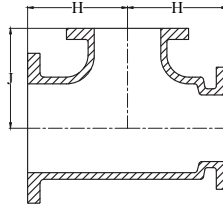

*Reducing on Run and Branch

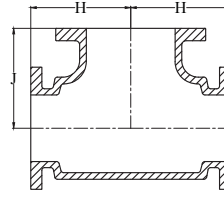

*Bullhead Tees

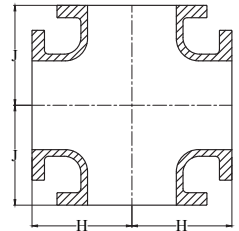

Straight and Reducing Crosses

TEES AND CROSSES								
Sizes					Domestic Weight		Import Weight	
Run	Run	Branch	H	J	Tee	Cross	Tee	Cross
12	12	4	12.00	12.00	322	310	290	—
12	12	6	12.00	12.00	297	326	295	—
12	12	8	12.00	12.00	346	351	310	—
12	12	10	12.00	12.00	394	415	360	—
12	12	12	12.00	12.00	369	438	385	—
*14	14	4	14.00	14.00	410	—	—	—
14	14	6	14.00	14.00	420	450	375	—
14	14	8	14.00	14.00	435	475	390	—
14	14	10	14.00	14.00	450	—	400	—
14	14	12	14.00	14.00	470	555	425	—
*14	14	14	14.00	14.00	500	595	435	—
*16	*14	4	15.00	15.00	525	—	—	—
16	*16	6	15.00	15.00	573	565	465	490
16	16	8	15.00	15.00	555	590	475	520
16	16	10	15.00	15.00	565	620	495	555
16	16	12	15.00	15.00	590	665	520	605
16	16	14	15.00	15.00	610	—	530	620
16	16	16	15.00	15.00	635	755	550	665
18	18	6	13.00	15.50	780	—	480	505
18	18	8	13.00	15.50	609	—	495	535
18	18	10	13.00	15.50	585	—	510	560
18	18	12	13.00	15.50	638	706	535	610
18	18	14	16.50	16.50	808	—	630	720
18	18	16	16.50	16.50	760	—	650	765
18	18	18	16.50	16.50	865	915	665	795
20	20	6	14.00	17.00	773	—	610	635
20	20	8	14.00	17.00	720	—	620	665
20	20	10	14.00	17.00	735	—	635	685
20	20	12	14.00	17.00	816	820	660	735
20	20	14	14.00	17.00	770	—	665	745
20	20	16	18.00	18.00	950	1065	810	915
20	20	18	18.00	18.00	965	—	820	945
20	20	20	18.00	18.00	1005	1175	855	1015
24	24	6	15.00	19.00	1089	—	845	875
24	24	8	15.00	19.00	1060	—	860	895
24	24	10	15.00	19.00	1020	—	88	930
24	24	12	15.00	19.00	1125	1100	890	960
24	24	14	15.00	19.00	1050	1125	900	975
24	24	16	15.00	19.00	1070	1160	915	1010
24	24	18	22.00	22.00	1534	—	1220	1365
24	24	20	22.00	22.00	1510	1695	1255	1430
24	24	24	22.00	22.00	1685	1850	1330	1570

* Not included in AWWA C110.