

DOMESTIC

NON-DOMESTIC

SUBMITTAL: C110 MECHANICAL JOINT PRODUCT

(Current revisions for the noted Standards apply)

- SIZES:** 2" - 48"
- STANDARDS:** ANSI/AWWA C110/A21.10, NFPA 13/24, 3" - 12" UL listed and approved (File - Tyler Union)
- MATERIAL:** Cast of ASTM A536 qualified ductile iron. Date code is cast on and required for traceability.
- PRESSURE RATING:** *Flanged fittings rated at 250 psi. Mechanical joints 2" - 24" rated at 350 psi and 30" - 48" at 250 psi.
*Note: With rubber annular ring flange gasket, 2" - 24" Flanged fittings can be rated at 350 psi.
Note: Wyes over 12" are not pressure rated. Contact Tyler Union for rating in your application.
- DEFLECTION:** Joint deflection 5° max for 2"- 12" and 3° max for 14"- 48". Reduces by 50% at nominal pipe & fitting diameters
- NSF-61 & NSF372:** Meets all requirements including Annex G, Tyler Union's Underwriters Laboratory listing MH16439.
- ASPHALT COATING:** Per ANSI/AWWA C104/A21.4 and ANSI/AWWA C110/A21.10.
- CEMENT LINING:** Per ANSI/AWWA C104/A21.4, with double cement lining available upon request.
- EPOXY COATING:** Fusion bonded epoxy per ANSI/AWWA C116/A21.16. Additional coatings available upon request.
- BARE FITTINGS:** Available upon request.
- FASTNERS:** High strength low alloy weathering steel per ANSI/AWWA C111/A21.11 and ASTM A242
- INSTALLATION:** Install per AWWA C600/C651 using pipe conforming to ANSI/AWWA C151/A21.51 or AWWA C900/905.

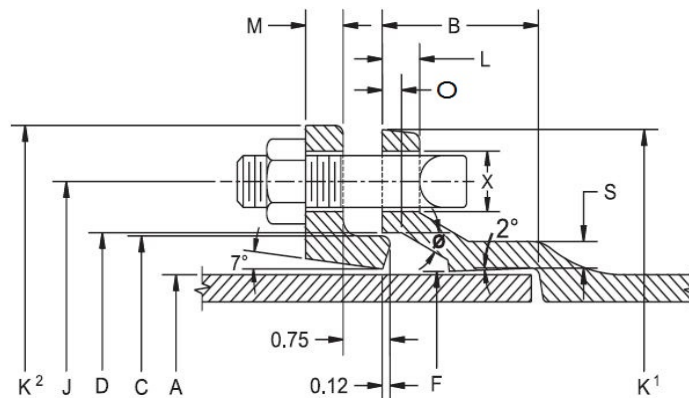

NOMINAL JOINT DIMENSIONS IN INCHES

Size Inches	A Dia. DI Pipe	B Hub Depth	C Dia. GLAND	D Dia.	F Dia.	∅	X	J Dia. GLAND	K ¹ Dia.	K ² Dia. GLAND	L	M GLAND	O	S	Qty. BOLTS
2	2.51	2.50	3.39	3.50	2.61	28°	3/4	4.75	6.25	6.25	0.73	0.62	0.31	0.44	2
3	3.96	2.50	4.84	4.94	4.06	28°	3/4	6.19	7.69	7.69	0.94	0.62	0.31	0.52	4
4	4.80	2.50	5.92	6.02	4.90	28°	7/8	7.50	9.12	9.12	1.00	0.75	0.31	0.65	4
6	6.90	2.50	8.02	8.12	7.00	28°	7/8	9.50	11.12	11.12	1.06	0.88	0.31	0.70	6
8	9.05	2.50	10.17	10.27	9.15	28°	7/8	11.75	13.37	13.37	1.12	1.00	0.31	0.75	6
10	11.10	2.50	12.22	12.34	11.20	28°	7/8	14.00	15.69	15.62	1.19	1.00	0.31	0.80	8
12	13.20	2.50	14.32	14.44	13.30	28°	7/8	16.25	17.94	17.88	1.25	1.00	0.31	0.85	8
14	15.30	3.50	16.40	16.54	15.44	28°	7/8	18.75	20.31	20.25	1.31	1.25	0.31	0.89	10
16	17.40	3.50	18.50	18.64	17.54	28°	7/8	21.00	22.56	22.50	1.38	1.31	0.31	0.97	12
18	19.50	3.50	20.60	20.74	19.64	28°	7/8	23.25	24.83	24.75	1.44	1.38	0.31	1.05	12
20	21.60	3.50	22.70	22.84	21.74	28°	7/8	25.50	27.08	27.00	1.56	1.44	0.31	1.12	14
24	25.80	3.50	26.90	27.04	25.94	28°	7/8	30.00	31.58	31.50	1.62	1.56	0.31	1.22	16
30	32.00	4.00	33.29	33.46	32.17	20°	1-1/8	36.88	39.12	39.12	1.81	2.00	0.38	1.50	20
36	38.30	4.00	39.59	39.76	38.47	20°	1-1/8	43.75	46.00	46.00	2.00	2.00	0.38	1.80	24
42	44.50	4.00	45.79	45.96	44.67	20°	1-3/8	50.62	53.12	53.12	2.00	2.00	0.38	1.95	28
48	50.80	4.00	52.09	52.26	50.97	20°	1-3/8	57.50	60.00	60.00	2.00	2.00	0.38	2.20	32

C110 DUCTILE IRON FULL BODY FITTINGS

SAMPLE SPECIFICATIONS

(Current ANSI/AWWA revisions apply)

Mechanical joint watermain fittings with accessories 2" through 48" shall be manufactured from ductile iron in accordance with and meet all applicable terms and provisions of standards ANSI/AWWA C110/A21.10 and ANSI/AWWA C111/A21.11. Ductile iron mechanical joint fittings 2" through 24" shall be rated for 350 psi working pressure. All ductile iron mechanical joint fittings 30" through 48" shall be rated for 250 psi working pressure. Flanged ductile iron fittings in 24" (610 mm) and smaller sizes may be rated for 350 psi (2,413 kPa) with the use of special (annular ring or comparable) gaskets.

NOTE: EXCEPTIONS: Mechanical joint fittings with flanged branches and 14" and larger caps and plugs are rated for water pressure of 250 PSI.

NOTE: Installation per AWWA C600 and AWWA C651, current revision.

NOTE: Fittings are cement lined and seal coated in accordance with ANSI/AWWA C104/A21.4. Fittings are also available double cement lined, bare or epoxy coated. Coated and lined fittings meet requirements of NSF-61, NSF-372 & Annex G.

Nominal Joint Dimensions in Inches															
Size	A	B	C	D	F	θ	X	J	K1	K2	L	M	N	O	S
*2	2.50	2.50	3.39	3.50	2.61	28°	3/4	4.75	6.25	6.25	0.75	0.62	1.12	0.31	0.44
3	3.96	2.50	4.84	4.94	4.06	28°	3/4	6.19	7.69	7.69	0.94	0.62	1.37	0.31	0.52
4	4.80	2.50	5.92	6.02	4.90	28°	7/8	7.50	9.12	9.12	1.00	0.75	1.50	0.31	0.65
6	6.90	2.50	8.02	8.12	7.00	28°	7/8	9.50	11.12	11.12	1.06	0.88	1.63	0.31	0.70
8	9.05	2.50	10.17	10.27	9.15	28°	7/8	11.75	13.37	13.37	1.12	1.00	1.75	0.31	0.75
10	11.10	2.50	12.22	12.34	11.20	28°	7/8	14.00	15.69	15.62	1.19	1.00	1.75	0.31	0.80
12	13.20	2.50	14.32	14.44	13.30	28°	7/8	16.25	17.94	17.88	1.25	1.00	1.75	0.31	0.85
14	15.30	3.50	16.40	16.54	15.44	28°	7/8	18.75	20.31	20.25	1.31	1.25	2.00	0.31	0.89
16	17.40	3.50	18.50	18.64	17.54	28°	7/8	21.00	22.56	22.50	1.38	1.31	2.06	0.31	0.97
18	19.50	3.50	20.60	20.74	19.64	28°	7/8	23.25	24.83	24.75	1.44	1.38	2.13	0.31	1.05
20	21.60	3.50	22.70	22.84	21.74	28°	7/8	25.50	27.08	27.00	1.50	1.44	2.19	0.31	1.12
24	25.80	3.50	26.90	27.04	25.94	28°	7/8	30.00	31.58	31.50	1.62	1.56	2.31	0.31	1.22
30	32.00	4.00	33.29	33.46	32.17	20°	1 1/8	36.88	39.12	39.12	1.81	2.00	2.75	0.38	1.50
36	38.30	4.00	39.59	39.76	38.47	20°	1 1/8	43.75	46.00	46.00	2.00	2.00	2.75	0.38	1.80
42	44.50	4.00	45.79	45.96	44.67	20°	1 3/8	50.62	53.12	53.12	2.00	2.00	2.75	0.38	1.95
48	50.80	4.00	52.09	52.26	50.97	20°	1 3/8	57.50	60.00	60.00	2.00	2.00	2.75	0.38	2.20

*Not included in AWWA C110.

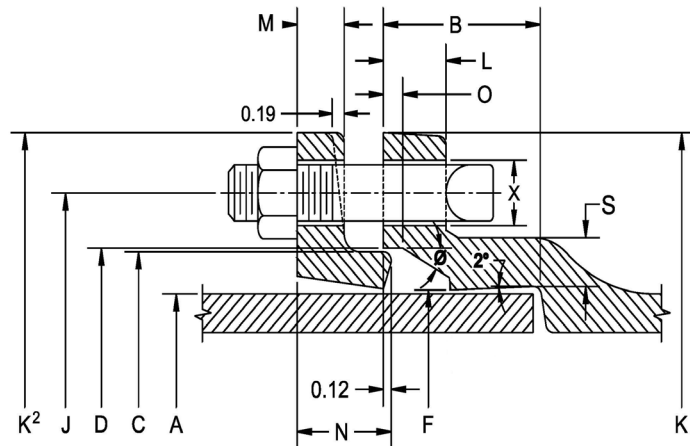

ANSI/AWWA C110 Mechanical Joint Fittings

C110 DUCTILE IRON FULL BODY FITTINGS

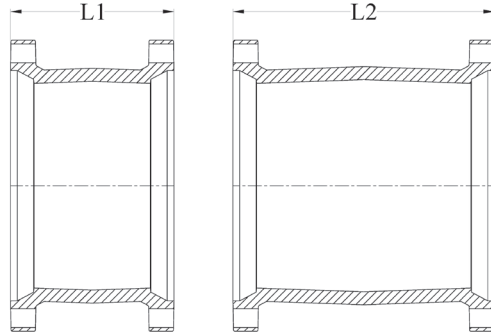
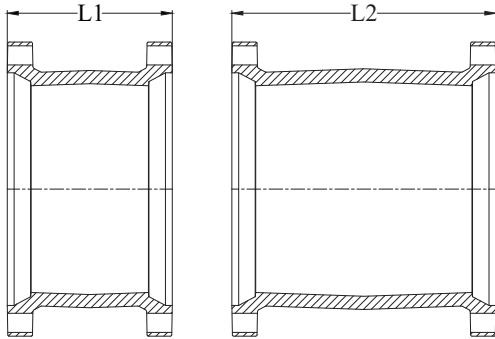

SOLID SLEEVES					
Size	Pipe O.D.	L1	Weight	L2	Weight
*2	2.50	8.00	13	12.00	18
3	4.00	7.50	25	12.00	36
4	4.80	7.50	35	12.00	47
6	6.90	7.50	45	12.00	65
8	9.10	7.50	65	12.00	90
10	11.10	7.50	85	12.00	108
12	13.20	7.50	120	12.00	136
16	17.40	9.50	206	15.00	289
18	19.50	9.50	246	15.00	282
20	21.60	9.50	275	15.00	336
24	25.80	9.50	360	15.00	459
30	32.00	15.00	745	24.00	1220
36	38.30	15.00	1047	24.00	1502
42	44.50	15.00	1312	24.00	1550
48	50.80	15.00	1585	24.00	1940

*DUO PURPOSE SLEEVE					
Size	Pipe O.D.	L1	Weight	L2	Weight
4	4.80/5.00	7.50	33	12.00	44
6	6.90/7.10	7.50	46	12.00	67
8	9.05/9.30	7.50	65	12.00	88
10	11.10/11.40	-	-	12.00	111
†12	13.20/13.50	-	-	12.00	221
†16	17.40/17.80	-	-	15.00	385

All sizes use MJ DUO purpose Gland.

* Not included in AWWA C110.

† 12" and 16" are sold assembled.

NOTE: Sizes 4"-10" Use standard MJ Gasket;

12" and 16" require special gaskets.

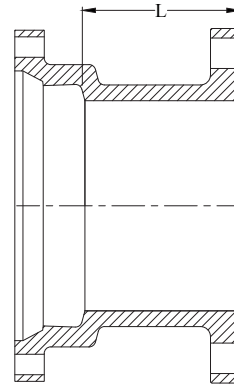
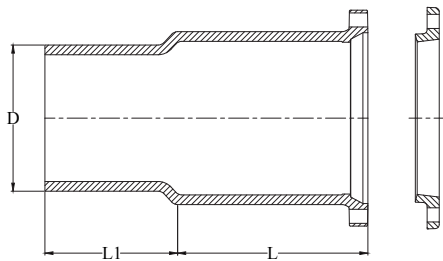

* MJ x PE DUAL-PURPOSE CUTTING-IN SLEEVE						
Size	For use on pipe OD	L	L1	D	Gland only	Gland and sleeve
4	4.80-5.00	12.00	8.00	4.80	6.0	72
6	6.90-7.10	12.00	8.00	6.90	10.0	94
8	9.05-9.30	12.00	8.00	9.05	16.0	122
10	11.10-11.40	12.00	8.00	11.10	25.0	175
12	13.20-13.50	12.00	8.00	13.20	30.0	235

Tyler Union does not recommend the use of wedge action restraints on plain end fittings

ADAPTERS MJxFE		
Size	L	Weight
3	8.00	30
4	8.00	42
6	8.00	57
8	8.00	88
10	8.00	120
12	8.00	150
16	8.00	257
18	8.00	304
20	8.00	372
24	8.00	488
30	10.00	682
36	10.00	1070