

DOMESTIC

NON-DOMESTIC

SUBMITTAL: C110 FLANGE JOINT CLASS 125 PRODUCT

(Current revisions for the noted Standards apply)

- SIZES:** 2" - 64" (Contact Tyler Union for 54" - 64" flange fitting information)
- STANDARDS:** ANSI/AWWA C110/A21.10, NFPA 13/24, ASME B16.1, 3" - 12" UL listed and FM approved
- MATERIAL:** Cast of ASTM A536 qualified ductile iron. Date code is cast on and required for traceability.
- PRESSURE RATING:** *Flanged fittings *2" - 48" rated at 250 psi. 54" - 64" rated at 150psi.
*Note: With rubber annular ring flange gasket, 2" - 24" flanged fittings can be rated at 350 psi.
- DEFLECTION:** Deflection is "not" recommended for flange joint due to the rigidity of the joint.
- NSF-61 & NSF372:** Meets all requirements including Annex G, Tyler Union's Underwriters Laboratory listing MH16439.
- COATING:** Asphaltic or Primer per ANSI/AWWA C104/A21.4, Standard primer is Tnemec Pota Pox N140-1211. Contact Tyler Union for additional coating options.
- CEMENT LINING:** Per ANSI/AWWA C104/A21.4, with double cement lining available upon request.
- EPOXY COATING:** Fusion bonded epoxy per ANSI/AWWA C116/A21.16. Additional coatings available upon request.
- BARE FITTINGS:** Available upon request.
- FLANGES:** ANSI Class 125 per ASME B16.1 and ANSI/AWWA C111/A21.11. Bolt holes shall straddle the center line
- NOTE: Class 125 ASME B16.1 are not compatible with Class 250 Flanges**
- NOTE: Class 250 ASME B16.1 fittings are available upon request.**
- FASTNERS:** High strength low alloy weathering steel per ANSI/AWWA C111/A21.11 and ASTM A242
- INSTALLATION:** Install per AWWA C600/C651 using pipe conforming to ANSI/AWWA C151/A21.51.

FLANGE DETAILS IN INCHES

BOLTS

Size Inches	Diameter DI Pipe	Flange O.D.	B.C. Diameter	Flange Thickness T	Bolt Hole Diameter	Size	Qty
2	2.51	6.00	4.75	0.62	0.750	5/8 x 2-1/4	4
3	3.96	7.50	6.00	0.75	0.750	5/8 x 2-1/4	4
4	4.80	9.00	7.50	0.94	0.750	5/8 x 3	8
6	6.90	11.00	9.50	1.00	0.875	3/4 x 3-1/2	8
8	9.05	13.50	11.75	1.12	0.875	3/4 x 3-1/2	8
10	11.10	16.00	14.25	1.19	1.000	7/8 x 4	12
12	13.20	19.00	17.00	1.25	1.000	7/8 x 4	12
14	15.30	21.00	18.75	1.38	1.125	1 x 4-1/2	12
16	17.40	23.50	21.25	1.44	1.125	1 x 4-1/2	16
18	19.50	25.00	22.75	1.56	1.250	1-1/8 x 5	16
20	21.60	27.50	25.00	1.69	1.250	1-1/8 x 5	20
24	25.80	32.00	29.50	1.88	1.375	1-1/4 x 5-1/2	20
30	32.00	38.75	36.00	2.12	1.375	1-1/4 x 5-1/2	28
36	38.30	46.00	42.75	2.38	1.625	1-1/2 x 7	32
42	44.50	53.00	49.50	2.62	1.625	1-1/2 x 7-1/2	36
48	50.80	59.50	56.00	2.75	1.625	1-1/2 x 8	44
54	Available on Request						
60	Available on Request						
64	Available on Request						

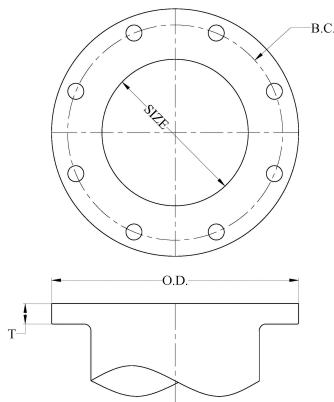

C110 DUCTILE IRON FULL BODY FITTINGS

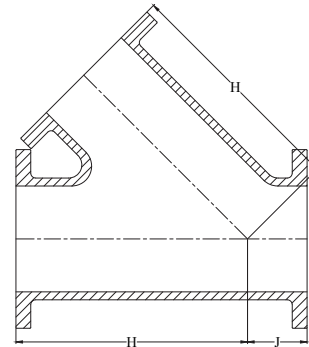
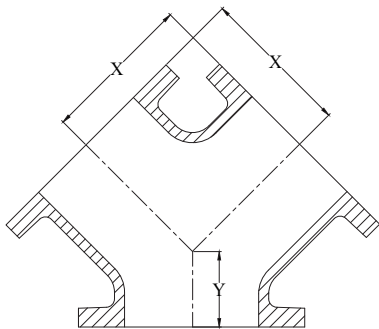

*TRUE WYES				
Sizes				Domestic
Stem	Branch	X	Y	Weight
4	4	6.50	3.00	49
6	4	8.00	3.50	75
6	6	8.00	3.50	84
8	6	9.00	4.50	134
8	8	9.00	4.50	125
10	6	8.00	5.00	140
10	8	9.00	5.00	155
10	10	11.00	5.00	220
12	8	9.00	5.50	210
12	10	11.00	5.50	240
12	12	12.00	5.50	315
16	16	13.00	6.50	520

*Not included in AWWA C110.

*WYES / LATERALS				
Sizes				Domestic
Run	Branch	H	J	Tee
3	3	10.00	3.00	49
4	3	12.00	3.00	68
4	4	12.00	3.00	76
6	4	14.50	3.50	106
6	6	14.50	3.50	131
8	4	17.50	4.50	153
8	6	17.50	4.50	188
8	8	17.50	4.50	201
10	4	20.50	5.00	232
10	6	20.50	5.00	288
10	8	20.50	5.00	333
10	10	20.50	5.00	300
12	4	24.50	5.50	355
12	6	24.50	5.50	370
12	8	24.50	5.50	395
12	10	24.50	5.50	420
12	12	24.50	5.50	460
14	6	27.00	6.00	500
14	8	27.00	6.00	525
14	10	27.00	6.00	555
14	12	27.00	6.00	600
14	14	27.00	6.00	640
16	6	30.00	6.50	655
16	8	30.00	6.50	680
16	10	30.00	6.50	715
16	12	30.00	6.50	755
16	14	30.00	6.50	800
16	16	30.00	6.50	850
18	8	32.00	7.00	820
18	10	32.00	7.00	855
18	12	32.00	7.00	1003
18	14	32.00	7.00	940
18	16	32.00	7.00	990
18	18	32.00	7.00	1035
20	10	35.00	8.00	1095
20	12	35.00	8.00	1130
20	14	35.00	8.00	1170
20	16	35.00	8.00	1220
20	20	35.00	8.00	1345
24	24	40.50	9.00	2020
36	36	60.00	19.50	5740

*Not included in AWWA C110.

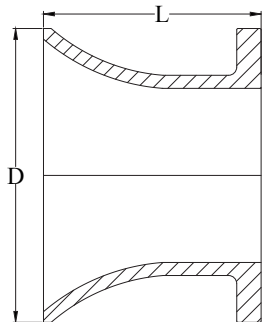

*FLANGE x FLARE PIECE			
Size	D	L	Weight
3	7.00	8.00	21
4	9.00	8.00	30
6	11.00	8.00	44
8	14.00	10.00	75
10	16.00	10.00	113
12	19.00	12.00	155
14	21.00	16.00	225
16	24.00	16.00	330
18	25.00	16.00	355
20	28.00	18.00	465
24	32.00	18.00	598
30	39.00	24.00	900
36	46.00	24.00	1200

*Not included in AWWA C110.