

Swing Check Valve

Model 92LW



Sizes 4" & 6" / 100 mm & 150 mm

Materials (Lever & Weight)

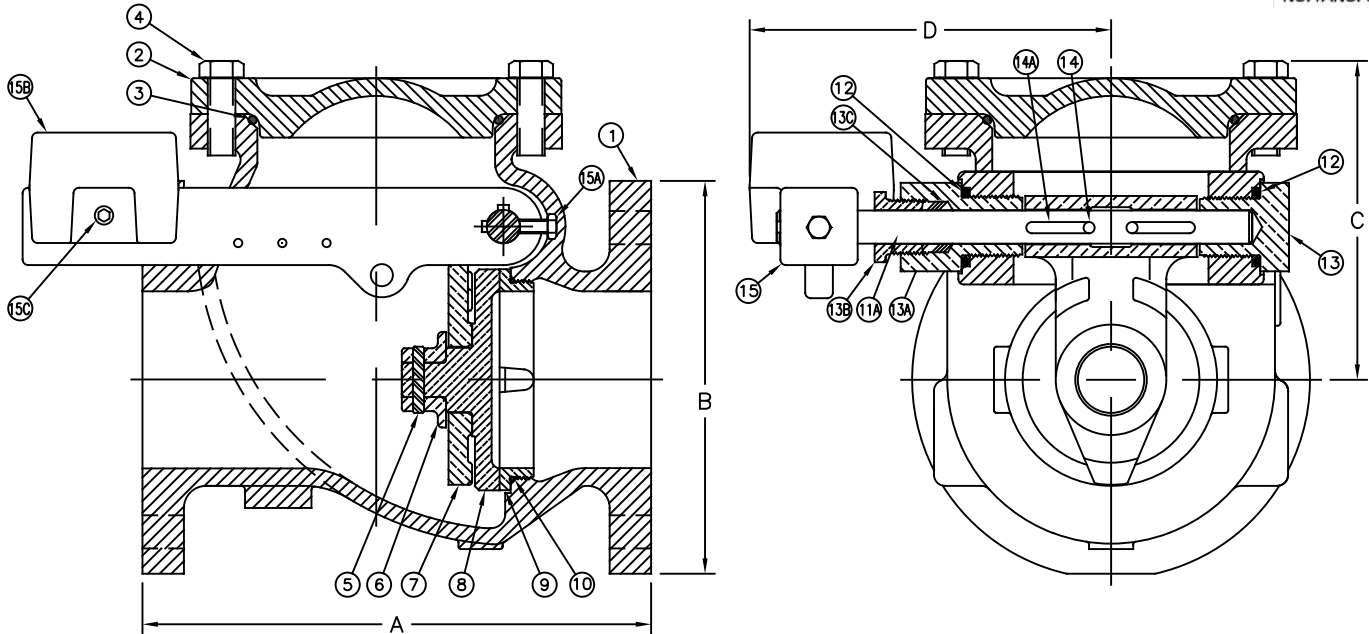
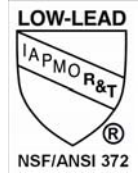

Max Temp 180°F (82°C)
Max Pressure 200psi (14bar)

Item #	Qty	Description	Material	ASTM	Item #	Qty	Description	Material	ASTM
1	1	Body*	Cast Iron	A126	12	2	Bearing O'Ring	Buna-n	-----
2	1	Cover*	Cast Iron	A126	13	1	Shaft Support Bearing	Bronze	B140
3	1	Cover O'Ring	Buna-n	-----	13A	1	Open End Support Shaft Bearing	Bronze	B140
4	4	Cover Bolt	Stainless Steel	18-8	13B	1	Shaft Packing Nut	Bronze	B140
5	1	Flapper End Cap Pin	Stainless Steel	18-8	13C	4	Teflon Packing	Teflon	-----
6	1	Flapper End Cap	Bronze	C89833	14	1	Screw	Stainless Steel	18-8
7	1	Hinge Lever Arm	Bronze	C89833	14A	3	Key Stock	Stainless Steel	18-8
8	1	Flapper Plate	Bronze	C89833	15	1	Lever Arm*	Ductile Iron	65-45-12
9	1	Seat Ring	Bronze	C89833	15A	1	Bolt	Stainless Steel	18-8
10	1	Seat Ring O'Ring	Buna-n	-----	15B	1	Weight*	Cast Iron	A126
11A	1	Flapper Support Shaft	Stainless Steel	17-4	15C	1	Bolt	Stainless Steel	18-8

*Epoxy Coated
Optional resilient seat (Nitrile) available, add "R" to end of part number

Dimensions (ANSI B16.1 - 125# Flanges)

Size		Part #	A		B		C		D		Weight	
inch	mm		inch	mm	inch	mm	inch	mm	inch	mm	lbs	kg
4	100	3707LW	11-1/2	292	8-57/64	226	7-7/32	183	8-3/16	208	125	57
6	150	3709LW	14	356	10-3/4	273	8-17/32	217	9-7/32	234	224	102

MANUFACTURED IN COMPLIANCE WITH AWWA C508 STANDARD

Flomatic Corporation can accept no responsibility for possible errors in catalogues, brochures and other printed material. Flomatic Corporation reserves the right to alter its products without notices. This also applies to product already agreed. All trademarks in this material are property of the respective companies. All right reserved. ©2018 Flomatic Corporation. The drawings & information on this drawing sheet are the sole & exclusive property of Flomatic Corporation. Any reproduction, distribution, display or use of these drawings or information in whole or in part without written authorization of Flomatic Corporation is strictly prohibited. www.flomatic.com



November 19, 2004
Dwg No:S3707LW Rev D (6/18)

FLOMATIC CORPORATION
GLENS FALLS, N.Y. 12801
PHONE (518) 761-9797
FAX (518) 761-9798