

SUBMITTAL INFORMATION

Snap Clamps - (FSC-xxx-x style)

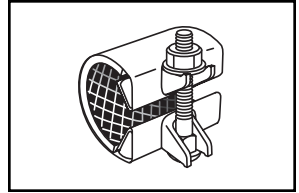

STAINLESS STEEL REPAIR CLAMPS FOR SMALL LEAKS

Lugs
Ductile Iron Lugs per ASTM
A536.

Washer
Carbon Steel Electrogalvanized
Flat Washer

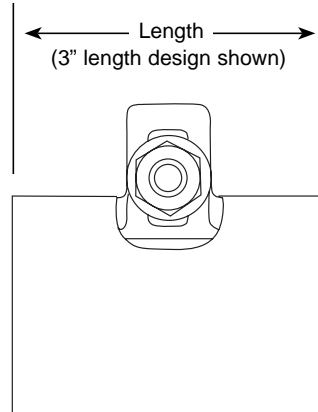
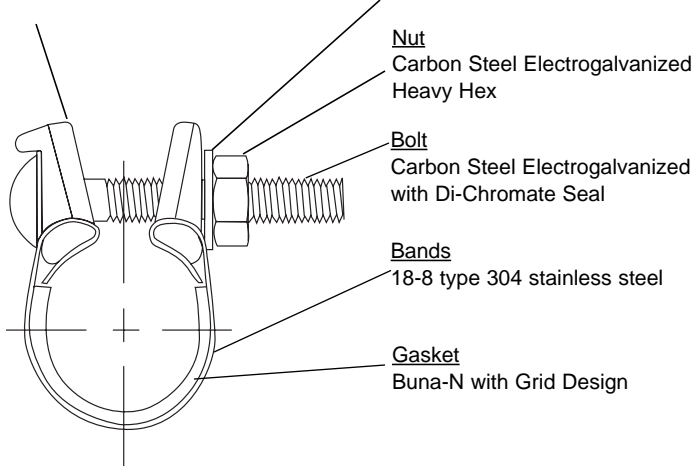

NOM. PIPE SIZE	PIPE O.D. RANGE	LENGTH AND APPROXIMATE WEIGHT (LBS.)				BOLT SIZE	CATALOG NUMBER FSC-XXX-LENGTH*	✓ SUBMITTED ITEM(S)
		3"	6"	9"	12"			
1/2"	0.08	0.6	1.21	-	-	3/8"x3-1/2"	FSC-084-	
3/4"	1.05	0.65	1.28	1.91	-		FSC-105-	
1"	1.32	0.66	1.31	2.0	-		FSC-132-	
1-1/4"	1.66	0.73	1.42	2.15	-		FSC-166-	
1-1/2"	1.90	0.74	1.44	2.75	2.86		FSC-190-	
2"	2.38	1.0	2.0	3.2	4.0		FSC-238	
2-1/2"	2.88	1.0	2.2	3.3	4.2	FSC-288-		
3"	3.50	1.4	2.6	4.0	5.2	FSC-350-		
3-1/2"	4.00	1.4	2.7	4.2	5.4	FSC-400-		
4"	4.50	1.4	2.8	4.2	5.6	FSC-450-		
5"	5.56	1.6	3.0	4.8	6.4	FSC-556-		
6"	6.00	1.9	3.5	5.0	6.7	FSC-600-		
	6.63	2.2	3.7	5.6	7.4	FSC-663-		
8"	8.00	2.2	4.4	6.6	8.0	FSC-800-		
	8.63	2.5	4.9	6.9	8.8	FSC-863-		
Number of Bolts		1	2	3	4			

*Add length option (3, 6, 9, or 12) to complete catalog number. Example: FSC-084-3

FEATURES AND OPTIONS

- Drop-in bolt design allows bolts to remain attached - no loose parts to lose in the ditch.
- Gaskets are heavy-grid design and extend lug to lug.
- Stainless Steel hardware is optional. Add "-SH" to end of catalog number. Example: FSC-084-3-SH

The Ford Meter Box Company considers the information in this submittal form to be correct at the time of publication. Item and option availability, including specifications, are subject to change without notice. Please verify that your product information is current.



The Ford Meter Box Company, Inc.

P.O. Box 443, Wabash, Indiana U.S.A. 46992-0443

Phone: 260-563-3171 / Fax: 800-826-3487

Overseas Fax: 260-563-0167

<http://www.fordmeterbox.com>

11/14/03

Submitted By: