

SERIES GL-RES/SW RESIDENTIAL HORIZONTAL SIDEWALL K-FACTOR: 4.2, 4.4

GENERAL DESCRIPTION

The series GL-RES/SW sprinkler is a decorative fast response glass bulb sprinkler specifically tested and Listed for use in residential applications such as homes, apartments, hotels, and dormitories to provide control of these residential type fires and to improve the chance for occupants to escape. It utilizes a 3mm frangible glass bulb as its heat sensing operating element. The recessed version of each of these Residential Sprinklers is intended for use in walls or soffits as appropriate. It employs a two-piece Recessed Escutcheon. The Recessed Escutcheon provides a total adjustment of 1/2 inch (12.7mm) from the flush ceiling position or $\pm 1/4$ inch (6.4mm) of recessed adjustment. The adjustment provided by the Recessed Escutcheon reduces the accuracy to which the pipe drops to the sprinklers must be cut.

This sprinkler may be installed within dwelling occupancies as allowed by NFPA 13, 13D, 13R and any other related documents as appropriate.

TECHNICAL DATA

Approvals

- See TABLE A

Maximum Working Pressure

- 175 psi (12 bar)

Temperature Rating

- See TABLE A

K-Factor

- GL4231 K4.2 gpm/psi^{1/2} (60.5 lpm/bar^{1/2})
- GL4431 K4.4 gpm/psi^{1/2} (63.4 lpm/bar^{1/2})

Thread Size

- 1/2" NPT (15 mm)

Length

- 2-1/2" (6.3 cm)

Materials of Construction

- Frame - bronze • Deflector - brass • Screw - brass
- Lodgement Wire - stainless steel • Bulb seat - copper
- Spring - nickel alloy • Seal - teflon
- Bulb - glass with alcohol based solution, 3mm
- Escutcheon Assembly - steel

NOTE:

Users should refer to Globe's web site (www.globesprinkler.com) to assure that the most recent technical literature is being utilized.



**SERIES GL-RES/SW
 GL4231, GL4431**

OPERATION

Upon exposure to heat such as from a fire, the fluid in the bulb expands, compressing the air bubble within the bulb. When the air bubble can no longer compress, the fluid expansion causes breakage of the glass bulb, resulting in release of the water seat assembly, and discharge of water from the sprinkler.

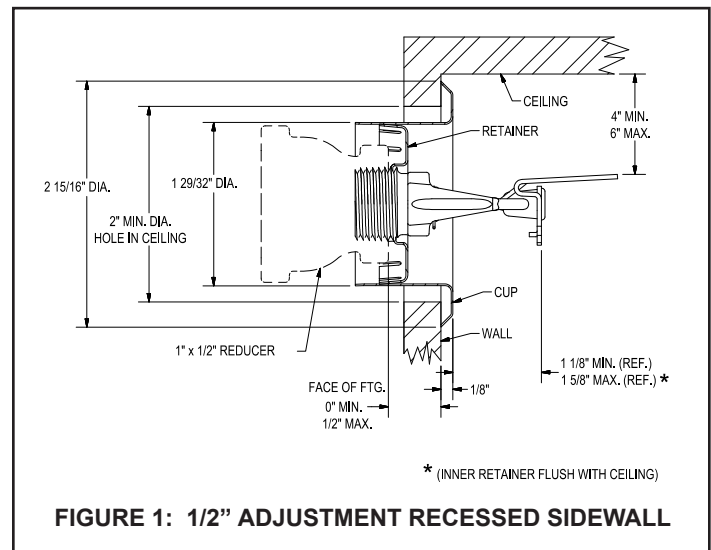

FINISHES AND ACCESSORIES

Finishes

- Factory Bronze • Chrome • White Polyester
- Black Polyester - *special order*

Escutcheons

- Brass • Chrome • White Polyester • Black Polyester

Wrenches

- Standard • Residential Sidewall Recess • 1/2" NPT

DESIGN CRITERIA

The Globe Residential Horizontal Sidewall Sprinkler Series GL-RES/SW is cULus Listed for installation in accordance with this data sheet as well as the applicable installation Standard being utilized.

Globe Residential Sprinkler Installation Guide

When conditions exist that are outside the scope of the provided criteria, refer to the Globe Residential Sprinkler Installation Guide (Document GFS-380) for recommendations that may be acceptable to the authority having jurisdiction.

Hydraulic Design (NFPA 13D and 13R)

For systems designed to NFPA 13D or NFPA 13R, the minimum required sprinkler flow rate is given in Table A for the coverage areas shown. The sprinkler flow rate is the minimum required discharge from each of the total number of "design sprinklers" as specified in NFPA 13D or NFPA 13R.

Hydraulic Design (NFPA 13)

The minimum required discharge from each design area sprinkler shall be the greater of the following:

- (1) In accordance with minimum flow rates indicated in TABLE A.
- (2) In rooms or compartments greater than 800 ft² (74.3 m²), calculated based on delivering a minimum of 0.1 gpm/ft² (4.1 mm/min) over the coverage area of each sprinkler, calculated in accordance with the S x L Rules for density area sprinklers.
- (3) In rooms or compartments 800 ft² (74.3 m²) or less (Defined as "Small Rooms") calculated based on delivering a minimum of 0.1 gpm/ft² (4.1 mm/min) over the room or compartment using the area of the room divided by the number of sprinklers in the room. (7 psi minimum)

**TABLE A: NFPA 13, 13R, AND 13D
HYDRAULIC AND INSTALLATION DESIGN CRITERIA**

SIN	K FACTOR GPM/PSI ^{1/2} (lpm/bar ^{1/2})	TEMPERATURE		MAX. AREA OF COVERAGE WIDTH x LENGTH ⁽²⁾ FEET (m)	MINIMUM PRESSURE PSI (bar)	MINIMUM FLOW GPM (L/min.)	DEFLECTOR TO CEILING DISTANCE INCHES (mm)	MINIMUM DISTANCE BETWEEN SPRINKLERS FEET (m)
		155°F (68°C)	175°F (79°C)					
GL4231	4.2 (60.5)	cULus EU ⁽¹⁾	cULus	12 (3.6) x 12 (3.6)	9.6 (.66)	13.0 (49)	4 (101.6) to 6 (152.4)	8 (2.4)
		cULus EU ⁽¹⁾	cULus	14 (4.3) x 14 (4.3)	12.8 (.88)	15.0 (57)		
		cULus EU ⁽¹⁾	cULus	16 (4.9) x 16 (4.9)	14.5 (1.0)	16.0 (61)		
		cULus EU ⁽¹⁾	cULus	16 (4.9) x 18 (5.5)	20.5 (1.41)	19.0 (72)		
		cULus EU ⁽¹⁾	cULus	16 (4.9) x 20 (6.1)	30.0 (2.07)	23.0 (87)		
GL4431	4.4 (63.4)	cULus EU ⁽¹⁾	NA	12 (3.6) x 12 (3.6)	8.7 (.6)	13.0 (49)	4 (101.6) to 6 (152.4)	8 (2.4)
		cULus EU ⁽¹⁾	NA	14 (4.3) x 14 (4.3)	11.6 (.80)	15.0 (57)		
		cULus EU ⁽¹⁾	NA	16 (4.9) x 16 (4.9)	13.2 (.91)	16.0 (61)		
		cULus EU ⁽¹⁾	NA	16 (4.9) x 18 (5.5)	18.7 (1.41)	19.0 (72)		
		cULus EU ⁽¹⁾	NA	16 (4.9) x 20 (6.1)	27.3 (1.88)	23.0 (87)		

⁽¹⁾ LISTED BY UNDERWRITERS LABORATORIES, INC. FOR USE IN THE U.S., CANADA, AND EUROPEAN UNION.

⁽²⁾ WIDTH REFERS TO LATERAL DISTANCE BETWEEN SPRINKLERS ALONG A WALL OR TWICE THE DISTANCE OFF AN END WALL IN THE CASE OF AN END SPRINKLER, WHICHEVER IS GREATER. LENGTH REFERS TO THE INTENDED COVERAGE AREA OUT FROM THE SPRINKLER (FORWARD THROW).

INSTALLATION

NOTICE

Do not install any bulb-type sprinkler if the bulb is cracked or there is loss of liquid from the bulb. Sprinklers should be tightened enough to obtain a leak-tight joint when water pressure is applied and/or hydrostatic test is performed. Sprinklers should not be overtightened as this can result in distortion and subsequent leakage. It is recommended not to exceed 14 ft.-lb. (19.0 Nm) torque for 1/2 inch NPT sprinkler threads.

- Step1.** Sprinklers must be properly oriented.
- Step2.** With pipe thread sealant applied to the pipe threads, hand tighten the sprinkler into the sprinkler fitting. *Note: Do not grasp the sprinkler by the deflector.*
- Step3.** Wrench-tighten the sprinkler using only the appropriate wrench. Wrenches are only to be applied to the sprinkler wrench flats or wrench hex as applicable. *Note: Do not apply wrench to frame arms.*

CARE AND MAINTENANCE

Prior to installation, it is important to read and follow the "Sprinkler Caution" sheet (GFS-840) included within each box of sprinklers. This sheet is available on Globe's web site (www.globesprinkler.com).

Always obtain permission from the proper authorities to shut down the affected fire protection system and notify all personnel who may be affected by this action before closing a fire protection system main control valve for maintenance work on the system that it controls.

Sprinklers should only be cleaned by means of gently dusting with a feather duster; otherwise, non-operation in the event of a fire or inadvertent operation may result.

Store sprinklers in a cool, dry place. Exposure to extreme heat will damage the thermal sensing element, possibly resulting in premature activation. Avoid direct sunlight.

Replace any sprinkler that shows any corrosion, damage, or loss of liquid from the glass bulb.

Do not attempt to paint or alter the sprinkler's coating in any manner after leaving the manufacturing plant.

Do not attach wiring, ropes, decorations or fixtures to a sprinkler.

Absence of an escutcheon, used to cover a ceiling hole, may delay sprinkler operation in a fire situation.

It is the owner's responsibility for inspection, testing and maintenance of the fire sprinkler system with all components and devices in accordance with the National Fire Protection Association Pamphlet 25 as well as any other requirements as set forth by the local Authority Having Jurisdiction (AHJ).



**FIGURE 2: STANDARD WRENCH
P/N 325390**

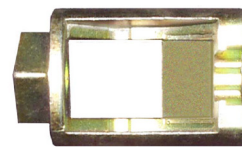

**FIGURE 3: RESIDENTIAL SIDEWALL
RECESSED WRENCH
P/N 327102**



ORDERING INFORMATION

TABLE B: PART NUMBER SELECTION

PART NUMBER
SIN + TEMPERATURE + FINISH

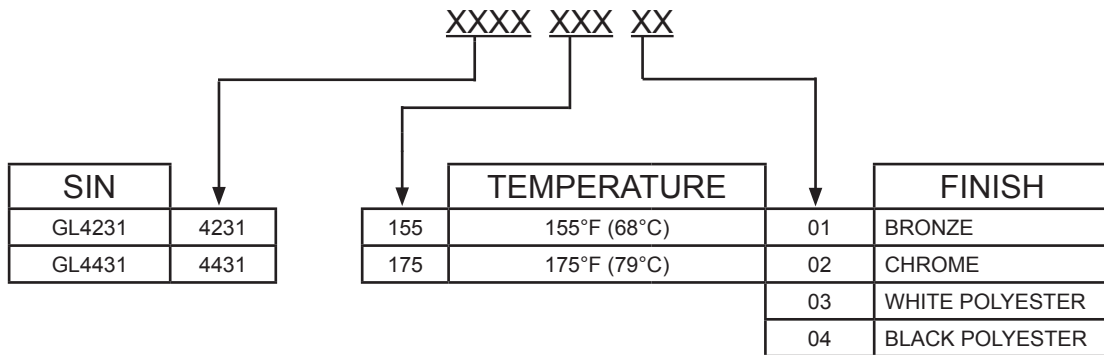

**Note: All combinations may not be available.
Refer to TABLE A for available listed combinations.**

TABLE C: ESCUTCHEONS

1/2" (13mm) ADJUSTABLE RECESSED ESCUTCHEON		
FINISH	FRICTION FIT 1/2" NPT	THREADED 1/2" NPT
Chrome	332071	329301
White Polyester	332073-W	329303-W
Brass	332072	NA
Black Polyester	332073-B	NA

SPECIFY:

- SPRINKLER
 - Quantity • SIN • Orientation • Temperature Rating • Finish
 - Part Number (See TABLE B)
- ESCUTCHEON
 - Quantity • Finish • Part Number (See TABLE C)
- WRENCH
 - Quantity • Part Number
 - 1/2" NPT Standard 325390
 - 1/2" NPT Residential Sidewall Recess . . . 327102
- PROTECTIVE CAPS
 - Quantity • Part Number
 - Cap. 327109-Cap

GLOBE® PRODUCT WARRANTY

Globe agrees to repair or replace any of its manufactured products found to be defective in material or workmanship for a period of one year from date of shipment.

For specific details of our warranty please refer to Price List Terms and Conditions of Sale (Our Price List).