

# Ball Check Valve

Sizes 1" Thru 2-1/2"/25mm Thru 65mm

**Model 508** **FLOMATIC**  
Flomatic Corporation

## Materials

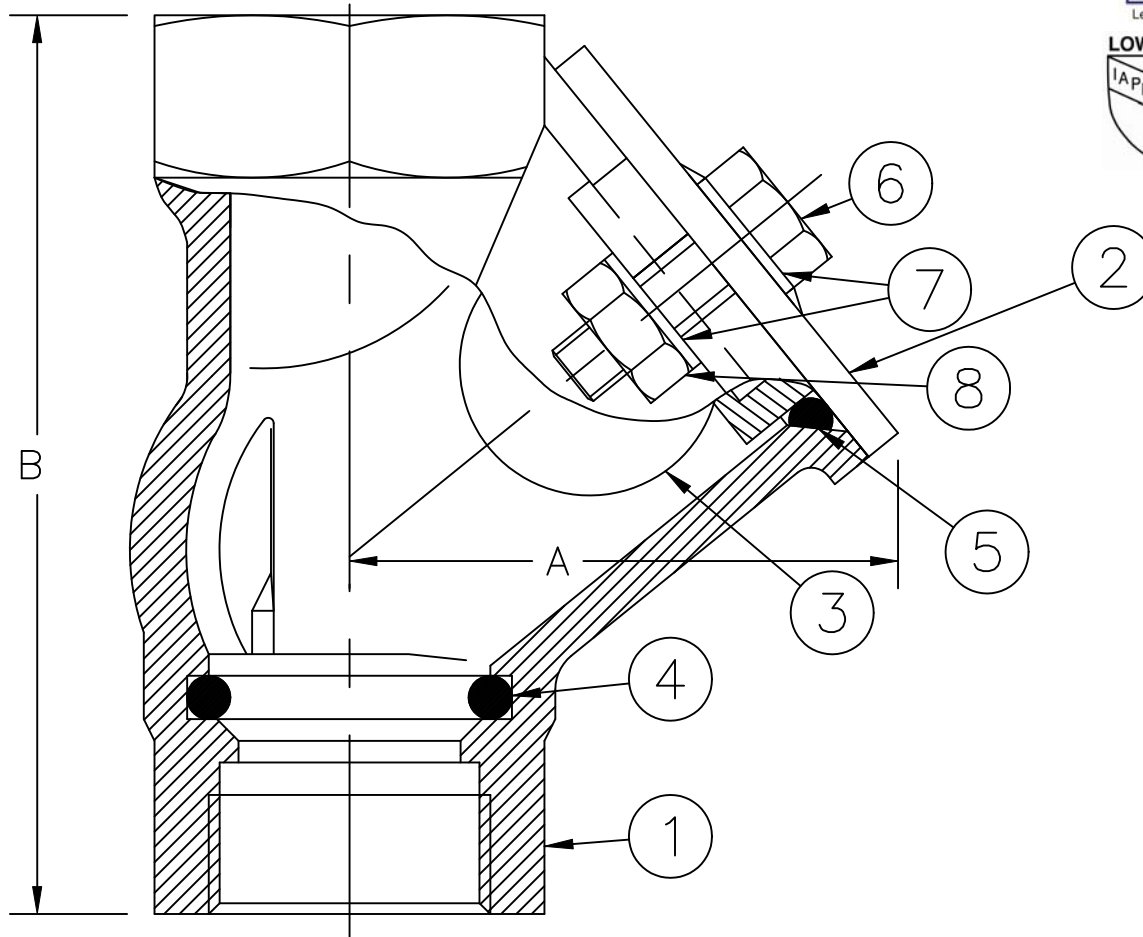

Item #	Qty	Description	Material	ASTM	Item #	Qty	Description	Material	ASTM
1	1	Body (Epoxy Coated)	Cast Iron	A48	5	1	Cover Seal	Nitrile	-----
2	1	Cover (Epoxy Coated)	Cast Iron	A48	6	2	Bolt	Stainless Steel	304
3	1	Ball (Sinking)*	Phenolic	-----	7	4	Washer	Stainless Steel	304
4	1	Seat Seal	Nitrile	-----	8	2	Hex Nut	Stainless Steel	304

\*Optional floating ball available add "FB" to part number

## Dimensions

Max Temp 180°F (82°C)  
Max Inlet Pressure 150 psi (10 bar)

Size		Part #	A		B		Width		Weight	
inch	mm		inch	mm	inch	mm	inch	mm	lbs	kg
1	25	3232	2-21/32	68	4-1/2	114	3-15/16	100	3.5	1.6
1-1/4	32	3233	3-7/64	79	5-13/64	132	4-1/4	108	4.5	2.1
1-1/2	40	3234	3-13/32	87	5-45/64	145	4-51/64	122	6	2.7
2	50	3235	4	102	6-27/32	174	5-7/16	138	8	3.6
2-1/2	65	3236	4-29/32	125	7-7/8	200	6-1/4	159	11.5	5.2

Flomatic Corporation can accept no responsibility for possible errors in catalogues, brochures and other printed material. Flomatic Corporation reserves the right to alter its products without notices. This also applies to product already agreed. All trademarks in this material are property of the respective companies. All right reserved. ©2011 Flomatic Corporation. The drawings & information on this drawing sheet are the sole & exclusive property of Flomatic Corporation. Any reproduction, distribution, display or use of these drawings or information in whole or in part without written authorization of Flomatic Corporation is strictly prohibited.