

INSTALLATION AND SERVICE MANUAL

gas-fired unit heaters

model PDP



All models approved for use in California by the CEC (when equipped with IPI), in New York by the MEA division, and in Massachusetts. Unit heater is certified for non-residential applications.

FOR YOUR SAFETY

If you smell gas:

1. Open windows.
2. Don't touch electrical switches.
3. Extinguish any open flame.
4. Immediately call your gas supplier.

WARNING

Improper installation, adjustment, alteration, service or maintenance can cause property damage, injury or death, and could cause exposure to substances which have been determined by various state agencies to cause cancer, birth defects or other reproductive harm. Read the installation, operating and maintenance instructions thoroughly before installing or servicing this equipment.

CAUTION

To prevent premature heat exchanger failure do not locate ANY gas-fired units in areas where chlorinated, halogenated, or acid vapors are present in the atmosphere.

FOR YOUR SAFETY

The use and storage of gasoline or other flammable vapors and liquids in open containers in the vicinity of this appliance is hazardous.

IMPORTANT

The use of this manual is specifically intended for a qualified installation and service agency. A qualified installation and service agency must perform all installation and service of these appliances.

Inspection on Arrival

1. Inspect unit upon arrival. In case of damage, report immediately to transportation company and your local Modine sales representative.
2. Check rating plate on unit to verify that power supply meets available electric power at the point of installation.
3. Inspect unit received for conformance with description of product ordered (including specifications where applicable).

SPECIAL PRECAUTIONS / TABLE OF CONTENTS

SPECIAL PRECAUTIONS

THE INSTALLATION AND MAINTENANCE INSTRUCTIONS IN THIS MANUAL MUST BE FOLLOWED TO PROVIDE SAFE, EFFICIENT AND TROUBLE-FREE OPERATION. IN ADDITION, PARTICULAR CARE MUST BE EXERCISED REGARDING THE SPECIAL PRECAUTIONS LISTED BELOW. FAILURE TO PROPERLY ADDRESS THESE CRITICAL AREAS COULD RESULT IN PROPERTY DAMAGE OR LOSS, PERSONAL INJURY, OR DEATH. THESE INSTRUCTIONS ARE SUBJECT TO ANY MORE RESTRICTIVE LOCAL OR NATIONAL CODES.

HAZARD INTENSITY LEVELS

1. **DANGER:** Indicates an imminently hazardous situation which, if not avoided, WILL result in death or serious injury.
2. **WARNING:** Indicates a potentially hazardous situation which, if not avoided, COULD result in death or serious injury.
3. **CAUTION:** Indicates a potentially hazardous situation which, if not avoided, MAY result in minor or moderate injury.
4. **IMPORTANT:** Indicates a situation which, if not avoided, MAY result in a potential safety concern.

DANGER

Appliances must not be installed where they may be exposed to a potentially explosive or flammable atmosphere.

WARNING

1. Gas fired heating equipment must be vented - do not operate unvented.
2. A built-in power exhauster is provided - additional external power exhausters are not required or permitted.
3. All field gas piping must be pressure/leak tested prior to operation. Never use an open flame. Use a soap solution or equivalent for testing.
4. Gas pressure to appliance controls must never exceed 14" W.C. (1/2 psi).
5. Disconnect power supply before making wiring connections to prevent electrical shock and equipment damage.
6. All appliances must be wired strictly in accordance with wiring diagram furnished with the appliance. Any wiring different from the wiring diagram could result in a hazard to persons and property.
7. Any original factory wiring that requires replacement must be replaced with wiring material having a temperature rating of at least 105°C.
8. When servicing or repairing this equipment, use only factory-approved service replacement parts. A complete replacement parts list may be obtained by contacting Modine Manufacturing Company. Refer to the rating plate on the appliance for complete appliance model number, serial number, and company address. Any substitution of parts or controls not approved by the factory will be at the owners risk.
9. To reduce the opportunity for condensation, the minimum sea level input to the appliance, as indicated on the serial plate, must not be less than 5% below the rated input, or 5% below the minimum rated input of dual rated units.
10. Ensure that the supply voltage to the appliance, as indicated on the serial plate, is not 5% greater than the rated voltage.

CAUTION

1. Purging of air from gas supply line should be performed as described in ANSI Z223.1 - latest edition "National Fuel Gas Code", or in Canada in CAN/CGA-B149 codes.
2. Do not attempt to reuse any mechanical or electronic ignition controllers which has been wet. Replace defective controller.
3. Ensure that the supply voltage to the appliance, as indicated on the serial plate, is not 5% less than the rated voltage.

IMPORTANT

1. To prevent premature heat exchanger failure, do not locate ANY gas-fired appliances in areas where corrosive vapors (i.e. chlorinated, halogenated or acid) are present in the atmosphere.
2. Do not attempt to attach ductwork of any kind to propeller models.
3. Start-up and adjustment procedures should be performed by a qualified service agency.
4. To check most of the Possible Remedies in the troubleshooting guide listed in Table 29.1, refer to the applicable sections of the manual.
5. To prevent premature heat exchanger failure, the input to the appliance, as indicated on the serial plate, must not exceed the rated input by more than 5%.

Table of Contents

Inspection on Arrival	1
Special Precautions	2
SI (Metric) Conversion Factors	3
Unit Location	3
Combustible Material and Service Clearances	3
Combustion Air Requirements	3
Unit Lifting and Unit Mounting	4
Installation	5
Venting	5
Gas Connections	7
Electrical Connections	8
Start-Up Procedure	9
Pilot Burner Adjustment	9
Main Burner Adjustment	10
Control Operating Sequence	11
Options	13
General Performance Data	14
Performance Data Options/Accessories	14
Dimensions Unit	15
Maintenance	16
Service & Troubleshooting	17
Model Nomenclature/Serial Plate	19
Commercial Warranty	Back Page

SI (METRIC) CONVERSION FACTORS / UNIT LOCATION

SI (METRIC) CONVERSION FACTORS

Table 3.1

To Convert	Multiply By	To Obtain	To Convert	Multiply By	To Obtain
"W.C.	0.24	kPa	CFH	1.699	m ³ /min
psig	6.893	kPa	Btu/ft ³	0.0374	mJ/m ³
°F	(°F-32) x 0.555	°C	pound	0.453	kg
inches	25.4	mm	Btu/hr	0.000293	kW/hr
feet	0.305	meters	gallons	3.785	liters
CFM	0.028	m ³ /min	psig	27.7	"W.C.

UNIT LOCATION

⚠ DANGER

Appliances must not be installed where they may be exposed to a potentially explosive or flammable atmosphere.

IMPORTANT

To prevent premature heat exchanger failure, do not locate ANY gas-fired appliances in areas where corrosive vapors (i.e. chlorinated, halogenated or acid) are present in the atmosphere.

Location Recommendations

- When locating the furnace, consider general space and heating requirements, availability of gas and electrical supply, and proximity to vent locations.
- Avoid installing units in extremely drafty locations. Drafts can cause burner flames to impinge on heat exchangers which shortens life. Maintain separation between units so discharge from one unit will not be directed into the inlet of another.
- Be sure the structural support at the unit location site is adequate to support the weight of the unit. For proper operation the unit must be installed in a level horizontal position.
- Do not install units in locations where the flue products can be drawn into the adjacent building openings such as windows, fresh air intakes, etc.
- Be sure that the minimum clearances to combustible materials and recommended service clearances are maintained. Units are designed for installation on non-combustible surfaces with the minimum clearances shown in Figure 3.1 and Tables 3.2 and 3.3.
- Units exposed to inlet air temperatures of 40°F or less, may experience condensation, therefore, provisions should be made for disposal of condensate.
- When locating units, it is important to consider that the exhaust vent piping must be connected to the outside atmosphere.
- In garages or other sections of aircraft hangars such as offices and shops that communicate with areas used for servicing or storage, keep the bottom of the unit at least 7 feet above the floor unless the unit is properly guarded to provide user protection from moving parts. In parking garages, the unit must be installed in accordance with the standard for parking structures ANSI/NFPA 88A, and in repair garages the standard for repair garages NFPA #88B. In Canada, installation of heaters in airplane hangars must be in accordance with the requirements of the enforcing authority, and in public garages in accordance with the current CAN/CGA-B149 codes.
- Do not install units in locations where gas ignition system is exposed to water spray, rain, or dripping water.
- Do not install units below 7 feet, measured from the bottom of the unit to the floor, unless properly guarded to provide protection from moving parts.

- In aircraft hangars, keep the bottom of the unit at least 10 feet from the highest surface of the wings or engine enclosure of the the highest aircraft housed in the hangar and in accordance with the requirements of the enforcing authority and/or NFPA No. 409 - Latest Edition.

Figure 3.1
Combustible Material and Service Clearances

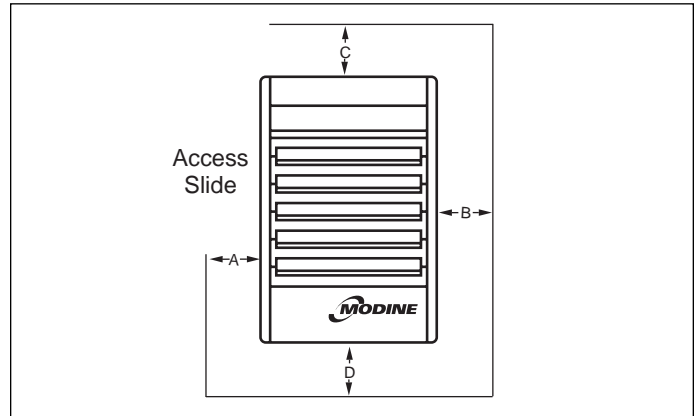

Table 3.2
Combustible Material Clearances ①

Model Size	Access Side (A)	Non-Access Side (B)	Top (C)	Bottom (D)	Top of Power Exhauster (Not Shown)
30-100	1	1	6	12	3
125	1	1	3	12	2
150-175	1	1	4	12	2
200-300	1	1	5	12	3
350-400	1	1	5	12	3

① Provide sufficient room around the heater to allow for proper combustion and operation of fan. Free area around the heater must not be less than 1-1/2 times the discharge area of the unit.

Table 3.3
Recommended Service Clearances

Model Size	Access Side (A)	Non-Access Side (B)	Top (C)	Bottom (D)	Top of Power Exhauster (Not Shown)
30-50	18	18	6	15	1
75-100	18	18	6	20	1
125-175	18	18	6	22	1
200-400	18	18	6	25	1

Combustion Air Requirements

Units installed in tightly sealed buildings or confined spaces must be provided with two permanent openings, one near the top of the confined space and one near the bottom. Each opening should have a free area of not less than one square inch per 1,000 BTU per hour of the total input rating off all units in the enclosure, freely communicating with interior areas having, in turn adequate infiltration from the outside. For further details on supplying combustion air to a confined (tightly sealed) space or unconfined space, see the National Fuel Gas Code ANSI Z223.1 of CAN/CGA B149.1 or .2 Installation Code, latest edition.

UNIT LOCATION

Sound and Vibration Levels

All standard mechanical equipment generates some sound and vibration that may require attenuation. Libraries, private offices and hospital facilities will require more attenuation, and in such cases, an acoustical consultant may be retained to assist in the application. Locating the equipment away from the critical area is desirable within ducting limitations. Generally, a unit should be located within 15 feet of a primary support beam. Smaller deflections typically result in reduced vibration and noise transmission.

UNIT LIFTING

All standard units are shipped fully boxed. Larger units are also supplied with skid supports on the bottom of the box. The larger units may be lifted from the bottom by means of a fork lift or other lifting device only if the shipping support skids are left in place and the forks support the whole depth of the unit. If the unit must be lifted from the bottom for final installation without the carton in place, be sure to properly support the unit over its entire length and width to prevent damage. When lifting units, make sure the load is balanced.

UNIT SUSPENSION

Be sure the method of unit suspension is adequate to support the weight of the unit (see Weights for base unit and factory installed option weights). For proper operation, the unit must be installed in a level horizontal position. Combustible material and service clearances as specified in Figure 3.1 and Tables 3.2 and 3.3 must be strictly maintained. To assure that flames are directed into the center of the heat exchanger tubes, the unit must be level in a horizontal position. Use a spirit level to ensure that the unit is suspended correctly.

The most common method of suspending Modine gas unit heaters is to utilize 3/8" threaded rod. On each piece of threaded rod used, screw a nut a distance of about one inch onto the end of the threaded rods that will be screwed into the unit heater. Then place a washer over the end of the threaded rod and screw the threaded rod into the unit heater weld nuts on the top of the heater at least 5 turns, and no more than 10 turns. Tighten the nut first installed onto the threaded rod to prevent the rod from turning. Drill holes into a steel channel or angle iron at the same centerline dimensions as the heater that is being installed. The steel channels or angle iron pieces need to span and be fastened to appropriate structural members. Cut the threaded rods to the preferred length, place them through the holes in the steel channel or angle iron and secure with washers and lock nuts or lock washers and nuts. A double nut arrangement can be used here instead of at the unit heater (a double nut can be used both places but is not necessary). Do not install standard unit heaters above the maximum mounting height shown in table 14.1.

On all propeller units, except sizes 350 and 400, two tapped holes (3/8-16) are located in the top of the unit to receive threaded rods.

Units with two point suspension, sizes 30 through 300, incorporate a level hanging feature. Depending on what options and accessories are being used, the heater may not hang level as received from the factory. Do not hang heaters with deflector hoods until referring to the "installation manual for deflector hoods" and making the recommended preliminary adjustments on the heater. These preliminary adjustments need to be made with the heater resting on the floor.

Propeller sizes 30 through 300 units without deflector hoods that do not hang level after being installed, can be corrected in place. Simply remove both outer side panels (screws to remove are on back flange of side panel) and you will see the (adjustable) mounting brackets (Fig. 4.1). Loosen the set screws holding the mounting brackets in place and using a rubber mallet or something similar, tap the heater into a position where the unit hangs level. Re-tighten set screws and replace the outer side panels.

Propeller sizes 350 and 400 have four mounting holes. On all blower units, except the 350 and 400, two tapped holes are provided in the top of the unit and two holes in the blower support bracket. The 350 and 400 have four tapped holes in the top of the unit and two in the blower support bracket for mounting.

NOTE: A pipe hanger adapter kit, shown in Figure 4.2 is available as an accessory. One kit consists of two drilled 3/4" IPS pipe caps and two 3/8 - 13 x 1-3/4" capscrews to facilitate threaded pipe suspension.

Figure 4.1
Adjustable Mounting Brackets - To Adjust:

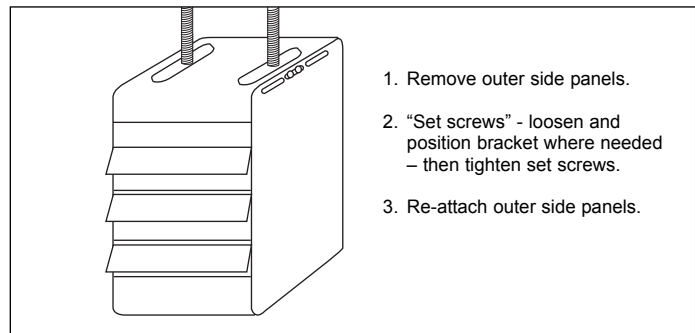
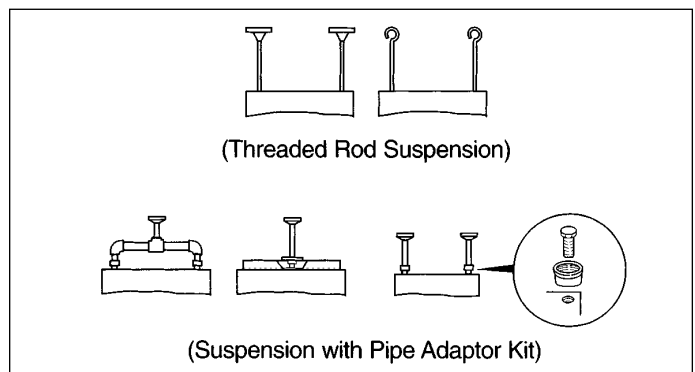

Figure 4.2
Suspension Methods



INSTALLATION

Venting

WARNING

1. Gas fired heating equipment must be vented - do not operate unvented.
2. A built-in power exhauster is provided - additional external power exhausters are not required or permitted.

Note: A **vent** is the vertical passageway used to convey flue gases from the unit or the vent connector to the outside atmosphere. A **vent connector** is the pipe which connects the unit to a vent or chimney. Vent connectors serving Category I appliances shall not be connected into any portion of mechanical draft systems operating under positive pressure.

General Venting Air Instructions

1. Installation of venting must conform with local building codes, or in the absence of local codes, with the National Fuel Gas Code, ANSI Z223.1 (NFPA 54) - Latest Edition. In Canada, installation must be in accordance with CAN/CGA-B149.1 for natural gas units and CAN/CGA-B149.2 for propane units.
2. All vertically vented units are Category I. All horizontally vented units are category III. The installation must conform to the requirements from Table 5.1 in addition to those listed below.
3. From Table 5.1, select the size of vent pipe that fits the flue outlet for the unit. Do not use a vent pipe smaller than the size of the outlet or vent transition of the appliance. The pipe should be suitable corrosion resistant material. Follow the National Fuel Gas Code for minimum thickness and composition of vent material. The minimum thickness for connectors varies depending on the pipe diameter.
4. For Category I vent systems limit length of horizontal runs to 75% of vertical height. Install with a minimum upward slope from unit of 1/4 inch per foot and suspend securely from overhead structure at points no greater than 3 feet apart. For best venting, put vertical vent as close to the unit as possible. A minimum of 12' straight pipe is recommended from the power exhauster outlet before turns in the vent system. Fasten individual lengths of vent together with at least three corrosion-resistant sheet-metal screws.
5. It is recommended that vent pipes be fitted with a tee with a drip leg and a clean out cap to prevent any moisture in the vent pipe from entering the unit. The drip leg should be inspected and cleaned out periodically during the heating season.
6. The National Fuel Gas Code requires a minimum clearance of 6 inches from combustible materials for single wall vent pipe. The minimum distance from combustible materials is based on the combustible material surface not exceeding 160°F. Clearance from the vent pipe (or the top of the unit) may be required to be greater than 6 inches if heat damage other than fire (such as material distortion or discoloration) could result.
7. Avoid venting through unheated space. When venting does pass through an unheated space, insulate runs greater than 5 feet to minimize condensation. Inspect for leakage prior to insulating and use insulation that is noncombustible with a rating of not less than 350°F. Install a tee fitting at the low point of the vent system and provide a drip leg with a clean out cap as shown in Figure 6.1.
8. When the vent passes through a combustible wall or floor, a metal thimble 4 inches greater than the vent diameter is necessary. If there is 6 feet or more of vent pipe in the open space between the appliance and where the vent pipe passes through the wall or floor, the thimble need only be 2 inches greater than the diameter of the vent pipe. If a

Table 5.1

ANSI Venting Requirements

Appliance Category	Description	Venting Requirements
I	Negative vent pressure Non-condensing	Follow standard venting requirements.
II	Negative vent pressure Condensing	Condensate must be drained.
III	Positive vent pressure Non-condensing	Vent must be gastight.
IV	Positive vent pressure Condensing	Vent must be liquid and gastight. Condensate must be drained.

thimble is not used, all combustible material must be cut away to provide 6 inches of clearance. Any material used to close the opening must be noncombustible.

9. Do NOT use dampers or other devices in the vent pipes.
10. Precautions must be taken to prevent degradation of building materials by flue products.
11. For category I vent systems the outlet of the vent should extend as shown in Figure 6.1 and Table 5.2 if the following conditions are met:
Vent diameter is less than 12 inches, vent is of double wall construction and is a listed product, and the vent does not terminate within 2' of a vertical wall or similar obstruction.
For vents that have a diameter of 12 inches or larger, constructed of single wall, or terminate within 2' of a vertical wall or similar obstruction, the vent pipe shall extend at least 2' higher than any portion of a building within a horizontal distance of 10' (refer to Figure 6.2).
12. Use a listed vent terminal to reduce downdrafts and moisture in vent.

Table 5.2

Minimum Height from Roof to Lowest Discharge Opening

Rise X (in)	Roof Pitch	Min Height H (ft)*
0-6	Flat to 6/12	1.00
6-7	6/12 to 7/12	1.25
7-8	7/12 to 8/12	1.50
8-9	8/12 to 9/12	2.00
9-10	9/12 to 10/12	2.50
10-11	10/12 to 11/12	3.25
11-12	11/12 to 12/12	4.00
12-14	12/12 to 14/12	5.00
14-16	14/12 to 16/12	6.00
16-18	16/12 to 18/12	7.00
18-20	18/12 to 20/12	7.50
20-21	20/12 to 21/12	8.00

* Size according to expected snow depth.

13. For instructions on common venting refer to the National Fuel Gas Code.
14. The vent must terminate no less than 5' above the vent connector for category I vent systems.
15. A unit located within an unoccupied attic or concealed space shall not be vented with single wall vent pipe.
16. Single wall vent pipe must not pass through any attic, inside wall, concealed space, or floor.
17. Do NOT vent this appliance into a masonry chimney.
18. When condensation may be a problem, the venting system shall not terminate over public walkways or over an area where condensation or vapor could create a nuisance or hazard or could be detrimental to the operation of regulator/relief openings or other equipment.

INSTALLATION

Figure 6.1
Unit Venting Category I (pitched roof)

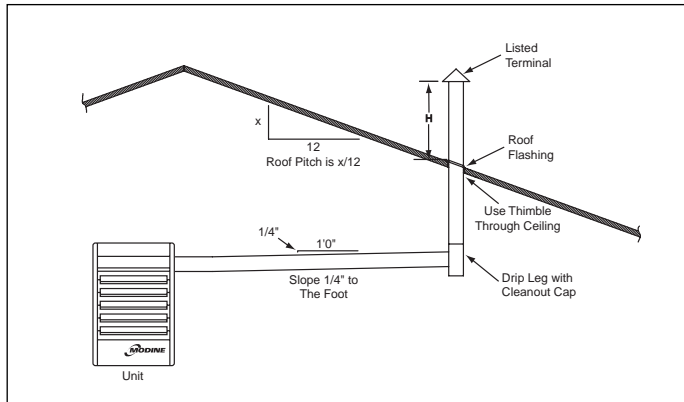
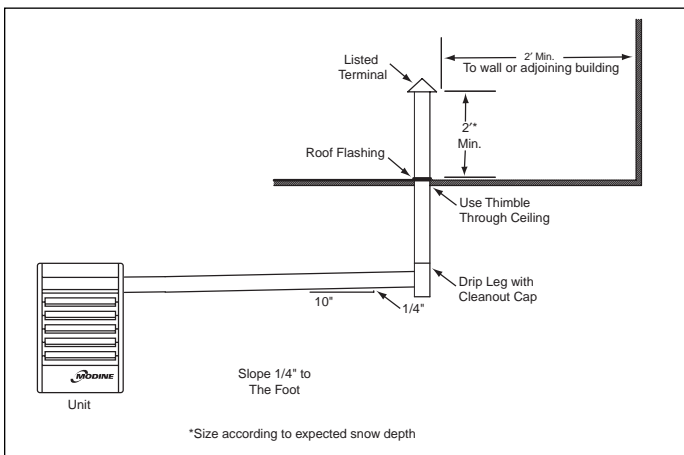

Figure 6.2
Unit Venting Category I (obstructed)



19. In cold ambient conditions, such as Canada, the following items are recommended for proper operation and equipment life:
 - The vent pipe must not pass through an unheated space or interior part of an open chimney unless the vent pipe is insulated.
 - Where the vent pipe may be exposed to extreme cold, or come into contact with snow or ice, the entire vent must be insulated or double wall (includes outdoors). It is preferred that the double wall vent is one continuous piece but a joint is allowed outside the building.
 - The vent terminal must extend 16 inches beyond the exterior surface of an exterior wall and be supported as shown in figure 7.1.
 - The heater system shall be checked at least once a year by a qualified service technician.
20. If left hand (facing front of heater with air blowing in face) power exhauster discharge is desired, the power exhauster may be rotated 180°. To do this, remove screws in vent colar, rotate power exhauster, replace screws.

Additional Requirements for Horizontally Vented Category III units.

1. Seal the joints with a metallic tape or silastic suitable for temperatures up to 350°F. (3M tapes 433 or 363 are acceptable.) Wrap the tape two full turns around the vent pipe.
2. Refer to Table 6.1 for total minimum and maximum vent lengths making the vent system as straight as possible. Refer to Table 6.2 for equivalent vent lengths for elbows.

Table 6.1
Vent Pipe Diameters, Transitions, and Total Equivalent Vent Pipe Lengths for Horizontal Vent Systems.

Model Size	Vent Transition Included	Vent Pipe Diameter	Minimum Eqv Length	Maximum Eqv Length
30	4" to 3"	3"	2'	25'
30	Not Required ①	4"	2'	35'
50	4" to 3"	3"	2'	30'
50	Not Required ①	4"	2'	40'
75	Not Required	4"	2'	40'
100-125	Not Required	4"	2'	55'
150, 175	4" to 5"	5"	2'	60'
200	6" to 5"	5"	2'	60'
250- 400	Not Required	6"	2'	70'

① Vent transition is included but not required for this vent size, Please discard the vent transition.

Table 6.2
Equivalent Vent Lengths for 90° Elbows

Elbow Diameter	Equivalent Vent Length
3"	1'
4"	5'
5"	6'
6"	7'

3. The vent terminal must be a Gary Steel 1092, Breidert Type L, Tjernlund VH1 (sizes 150-400 only), Starkap, Selkirk, or Constant Air-Flo 2433 style terminal or equivalent.
4. If a Gary Steel 1092 or Breidert Type L vent terminal or equivalent is used, the vent must extend 6 inches beyond the exterior surface of an exterior wall as shown in Figure 7.2. Precautions must be taken to prevent degradation of building materials by flue products.
5. If a Tjernlund VH1 or equivalent vent terminal is used the vent may be flush with the exterior surface of an exterior wall. Precautions must be taken to prevent degradation of building materials by flue products. Where the terminal is not available in the appropriate size for the unit to be installed, use a transition and the next larger size terminal.
6. If a Constant Air-Flo, Starkap, Selkirk, or equivalent vent terminal is used the vent must extend 12 inches beyond the exterior surface of an exterior wall. Precautions must be taken to prevent degradation of building materials by flue products.
7. The vent system shall terminate at least 3 feet above any forced air inlet (except direct vent units) located within 10 feet, and at least 4 feet below, 4 feet horizontally from, or 1 foot above any door, window, or gravity air inlet into any building. The bottom of the vent terminal shall be located above the snow line or at least 1 foot above grade; whichever is greater. When located adjacent to public walkways the vent system shall terminate not less than 7 feet above grade.
8. The venting system must be exclusive to a single unit, and no other unit is allowed to be vented into it.

INSTALLATION

Figure 7.1
Vent Construction Through Combustible Walls

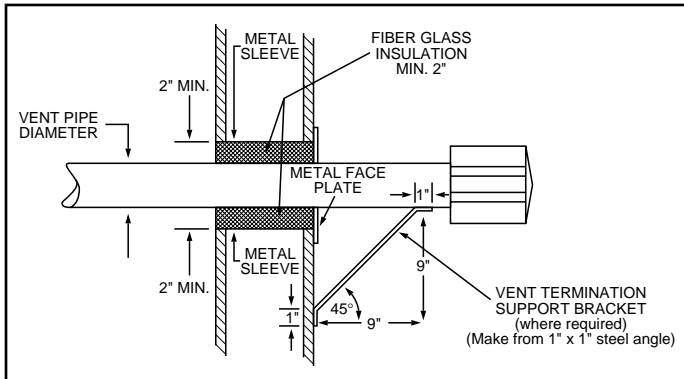
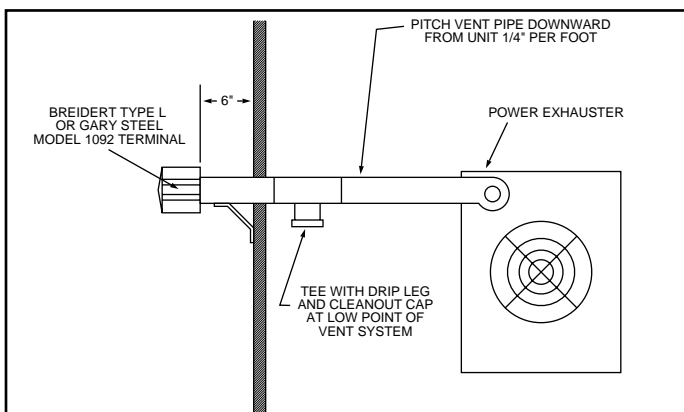

Figure 7.2
Horizontal Venting - Breidert or Gary Steel Vent Terminal



Gas Connections

⚠ WARNING

1. All field gas piping must be pressure/leak tested prior to operation. Never use an open flame. Use a soap solution or equivalent for testing.
2. Gas pressure to appliance controls must never exceed 14" W.C. (1/2 psi).
3. To reduce the opportunity for condensation, the minimum sea level input to the appliance, as indicated on the serial plate, must not be less than 5% below the rated input, or 5% below the minimum rated input of dual rated units.

⚠ CAUTION

Purging of air from gas supply line should be performed as described in ANSI Z223.1 - latest edition "National Fuel Gas Code", or in Canada in CAN/CGA-B149 codes.

IMPORTANT

To prevent premature heat exchanger failure, the input to the appliance, as indicated on the serial plate, must not exceed the rated input by more than 5%.

1. Installation of piping must conform with local building codes, or in the absence of local codes, with the National Fuel Gas Code, ANSI Z223.1 (NFPA 54) - Latest Edition. In Canada, installation must be in accordance with CAN/CGA-B149.1 for natural gas units and CAN/CGA-B149.2 for propane units.
2. Piping to units should conform with local and national requirements for type and volume of gas handled, and pressure drop allowed in the line. Refer to Table 13.1 to determine the cubic feet per hour (cfh) for the type of gas and size of unit to be installed. Using this cfh value and the length of pipe necessary, determine the pipe diameter from Table 8.1. Where several units are served by the same main, the total capacity, cfh and length of main must be considered. Avoid pipe sizes smaller than 1/2". Table 8.1 allows for a 0.3" W.C. pressure drop in the supply pressure from the building main to the unit. The inlet pressure to the unit must be 6-7" W.C. for natural gas and 11-14" W.C. for propane gas. When sizing the inlet gas pipe diameter, make sure that the unit supply pressure can be met after the 0.3" W.C. has been subtracted. If the 0.3" W.C. pressure drop is too high, refer to the Gas Engineer's Handbook for other gas pipe capacities.
3. Install a ground joint union with brass seat and a manual shut-off valve adjacent to the unit for emergency shut-off and easy servicing of controls, including a 1/8" NPT plugged tapping accessible for test gauge connection (See Figure 7.1).
4. Provide a sediment trap before each unit and in the line where low spots cannot be avoided. (See Figure 7.1).
5. When Pressure/Leak testing, pressures above 14" W.C. (1/2 psi), close the field installed shut-off valve, disconnect the appliance and its combination gas control from the gas supply line, and plug the supply line before testing. When testing pressures 14" W.C. (1/2 psi) or below, close the manual shut-off valve on the appliance before testing.

Figure 7.1
Recommended Sediment Trap/Manual Shut-off Valve Installation — Side or Bottom Gas Connection

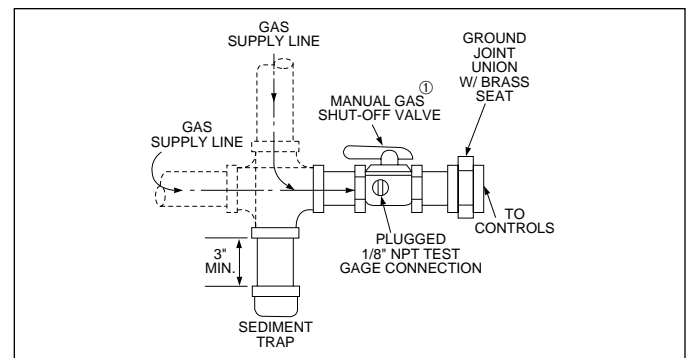

① Manual shut-off valve is in the "OFF" position when handle is perpendicular to pipe.

INSTALLATION

**Table 8.1
Gas Pipe Capacities**

Gas Pipe Capacities (Up to 14" W.C. Gas Pressure through Schedule 40 Pipe) Cubic Feet per Hour with Pressure Drop of 0.3" W.C. Natural Gas - Specific Gravity - 0.60 Propane Gas - Specific Gravity - 1.50												
Length Of Pipe (feet)	Pipe Diameter											
	1/2"		3/4"		1"		1-1/4"		1-1/2"		2"	
	Natural	Propane	Natural	Propane	Natural	Propane	Natural	Propane	Natural	Propane	Natural	Propane
10	132	83	278	175	520	328	1050	662	1600	1008	3050	1922
20	92	58	190	120	350	221	730	460	1100	693	2100	1323
30	73	46	152	96	285	180	590	372	890	561	1650	1040
40	63	40	130	82	245	154	500	315	760	479	1450	914
50	56	35	115	72	215	135	440	277	670	422	1270	800
60	50	32	105	66	195	123	400	252	610	384	1150	725
70	46	29	96	60	180	113	370	233	560	353	1050	662
80	43	27	90	57	170	107	350	221	530	334	990	624
90	40	25	84	53	160	101	320	202	490	309	930	586
100	38	24	79	50	150	95	305	192	460	290	870	548
125	34	21	72	45	130	82	275	173	410	258	780	491
150	31	20	64	40	120	76	250	158	380	239	710	447

Electrical Connections

WARNING

1. Disconnect power supply before making wiring connections to prevent electrical shock and equipment damage.
2. All appliances must be wired strictly in accordance with wiring diagram furnished with the appliance. Any wiring different from the wiring diagram could result in a hazard to persons and property.
3. Any original factory wiring that requires replacement must be replaced with wiring material having a temperature rating of at least 105°C.
4. Ensure that the supply voltage to the appliance, as indicated on the serial plate, is not 5% greater than rated voltage.

CAUTION

1. Ensure that the supply voltage to the appliance, as indicated on the serial plate, is not 5% less than the rated voltage.
1. Installation of wiring must conform with local building codes, or in the absence of local codes, with the National Electric Code ANSI/NFPA 70 - Latest Edition. Unit must be electrically grounded in conformance to this code. In Canada, wiring must comply with CSA C22.1, Part 1, Electrical Code.
2. Two copies of the unit wiring diagram are provided with each unit. One is located in the electrical junction box and the other is supplied in the literature packet. Refer to this diagram for all wiring connections.
3. Make sure all multi-voltage components (motors, transformers, etc.) are wired in accordance with the power supply voltage.
4. The power supply to the unit must be protected with a fused or circuit breaker switch.

5. The power supply must be within 10 percent of the voltage rating and each phase must be balanced within 2 percent of each other. If not, advise the utility company.
6. External electrical service connections that must be installed include:
 - a. Supply power connection (120, 208, 240, 480, or 600 volts).
 - b. Connection of thermostats, summer/winter switches, or any other accessory control devices that may be supplied (24 volts).

NOTE: Propeller units supplied with 460/575 power will require the use of a field step-down transformer. Refer to the serial plate to determine the unit supply voltage required. Additional information may be found in table 16.1 and in the step down transformer installation instructions.
7. Refer to Figure 15.1 for the electrical junction box locations.
8. All supply power electrical connections are made in the electrical junction box of the unit. The low voltage (thermostat and accessory control devices) can be wired to the terminals on the electrical junction box. Refer to the wiring diagram for the terminal location of all low voltage wiring.

START-UP PROCEDURE

IMPORTANT

Start-up and adjustment procedures should be performed by a qualified service agency.

1. Turn off power to the unit at the disconnect switch. Check that fuses or circuit breakers are in place and sized correctly. Turn all hand gas valves to the "OFF" position.
2. Remove electrical junction box cover.
3. Check that the supply voltage matches the unit supply voltage listed on the Model Identification plate. Verify that all wiring is secure and properly protected. Trace circuits to insure that the unit has been wired according to the wiring diagram.
4. Check to insure that the venting system is installed correctly and free from obstructions.
5. Check to see that there are no obstructions to the intake and discharge of the unit.
6. For blower units, check the belt tension and sheave alignment. Refer to Blower Adjustments for proper belt tension.
7. Check bearings for proper lubrication (if applicable).
8. Check to make sure that all filters are in place and that they are installed properly according to direction of air flow (if applicable).
9. Perform a visual inspection of the unit to make sure no damage has occurred during installation.
10. Check that all horizontal deflector blades are open a minimum of 30° as measured from vertical.
11. Turn on power to the unit at the disconnect switch. Check to insure that the voltage between appliance electrical box terminals T1 and G is 24V.
12. Check the thermostat, ignition control, gas valve, and supply fan blower motor for electrical operation. If these do not function, recheck the wiring diagram. Check to insure that none of the Control Options have tripped.
13. Check the blower wheel for proper direction of rotation when compared to the air flow direction arrow on the blower housing (if applicable). Blower wheel rotation, not air movement, must be checked as some air will be delivered through the unit with the blower wheel running backwards.
14. For blower units, check the blower speed (rpm). Refer to Blower Adjustments for modification.
15. Check the motor speed (rpm).
16. Check the motor voltage. On three phase systems, check to make sure all legs are in balance.
17. Check the motor amp draw to make sure it does not exceed the motor nameplate rating. On three phase systems, check all legs to insure system is balanced.
18. Recheck the gas supply pressure at the field installed manual shut-off valve. The minimum inlet pressure should be 6" W.C. on natural gas and 11" W.C. on propane gas. The maximum inlet pressure for either gas is 14" W.C. If inlet pressure exceeds 14" W.C., a gas pressure regulator must be added upstream of the combination gas valve.
19. Open the field installed manual gas shut-off valve.
20. Open the manual main gas valve on the combination gas valve. Call for heat with the thermostat and allow the pilot to light for intermittent pilot ignition. For standing pilot systems manually light the pilot prior to call for heat. If the pilot does not light, purge the pilot line. If air purging is required, disconnect the pilot line at outlet of pilot valve. In no case should line be purged into heat exchanger. Check the pilot flame length (See Pilot Flame Adjustment).
21. Once the pilot has been established, check to make sure that the main gas valve opens. Check the manifold gas pressure (See Main Gas Adjustment) and flame length (See Air Shutter Adjustment) while the supply fan blower is operating.
22. Check to insure that gas controls sequence properly (See Control Operating Sequence). Verify if the unit has any additional control devices and set according to the instructions in the Control Options.
23. Once proper operation of the unit has been verified, remove any jumper wires that were required for testing.
24. Replace the electrical junction box cover.

Pilot Burner Adjustment

The pilot burner is orificed to burn properly with an inlet pressure of 6-7" W.C. on natural gas and 11-14" W.C. on propane gas, but final adjustment must be made after installation. If the pilot flame is too long or large, it is possible that it may cause soot and/or impinge on the heat exchanger causing failure. If the pilot flame is shorter than shown, it may cause poor ignition and result in the controls not opening the combination gas control. A short flame can be caused by a dirty pilot orifice. Pilot flame condition should be observed periodically to assure trouble-free operation.

To Adjust the Pilot Flame

1. Create a call for heat from the thermostat.
2. Remove the cap from the pilot adjustment screw. For location, see the combination gas control literature supplied with unit.
3. Adjust the pilot length by turning the screw in or out to achieve a soft steady flame 3/4" to 1" long and encompassing 3/8"-1/2" of the tip of the thermocouple or flame sensing rod (See Figure 10.1).
4. Replace the cap from the pilot adjustment screw.

START-UP PROCEDURE

Figure 10.1
Correct Pilot Flame

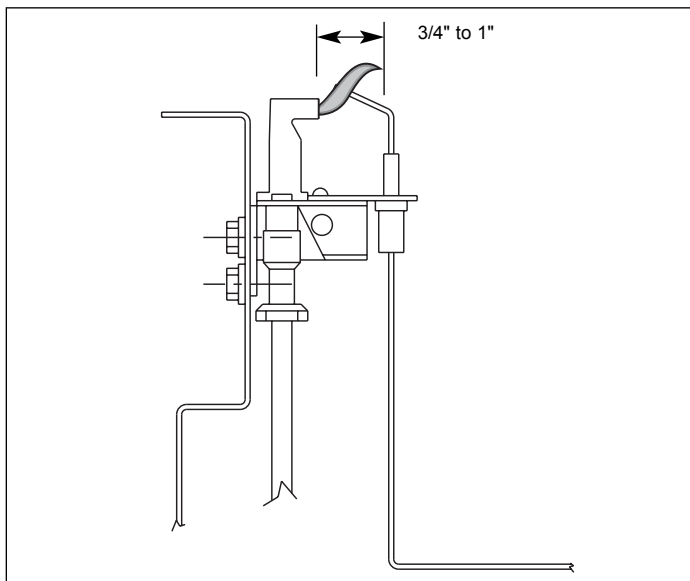

Main Burner Adjustment

The gas pressure regulator (integral to the combination gas control) is adjusted at the factory for average gas conditions. It is important that gas be supplied to the unit heater in accordance with the input rating on the serial plate. Actual input should be checked and necessary adjustments made after the unit heater is installed. Over-firing, a result of too high an input, reduces the life of the appliance and increases maintenance. Under no circumstances should the input exceed that shown on the serial plate.

Measuring the manifold pressure is done at the outlet pressure tap of the gas valve. (See Figure 10.2).

To Adjust the Manifold Pressure

1. Move the field installed manual shut-off valve to the "OFF" position.
2. Remove the 1/8" pipe plug in the pipe tee or gas valve and attach a water manometer of "U" tube type which is at least 12" high.
3. Move the field installed manual gas shut-off valve to the "ON" position.
4. Create a high fire call for heat from the thermostat.
5. Determine the correct high fire manifold pressure. For natural gas 3.5" W.C., for propane gas 10" W.C. Adjust the main gas pressure regulator spring to achieve the proper manifold pressure (for location, see the combination gas control literature supplied with unit).
6. After adjustment, move the field installed manual shut-off valve to the "OFF" position and replace the 1/8" pipe plug.
7. After the plug is in place, move the field installed manual shut-off valve to the "ON" position and recheck pipe plugs for gas leaks with soap solution.

Figure 10.2
Typical Combination Gas Control

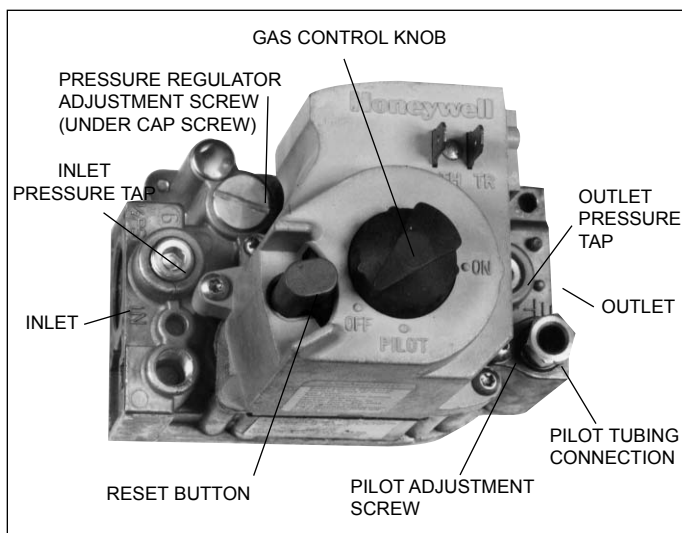

Burner Flame Adjustment

Proper operation provides a soft blue flame with a well-defined inner core. A lack of primary air will reveal soft yellow-tipped flames. Excess primary air produces short, well-defined flames with a tendency to lift off the burner ports. For both natural and propane gas, the flame may be adjusted by sliding the manifold. Also, for propane gas, the air shutters can be adjusted to control the burner flame height. The air shutters can be accessed by lowering the bottom pan of the unit heater.

Natural Gas Flame Control

Control of burner flames on unit heaters utilizing natural gas is achieved by resetting the manifold position to either increase or decrease primary combustion air. Prior to flame adjustment, operate unit heater for about fifteen minutes. The main burner flame can be viewed after loosening and pushing aside the gas designation disc on the back of the unit.

To increase primary air, loosen the manifold mounting screws and move the manifold away from the burner until the yellow-tipped flames disappear (see figure 11.1). To decrease primary air, move manifold closer to the burner until flames no longer lift from burner ports, but being careful not to cause yellow tipping. Retighten manifold mounting screws after adjustment.

Propane Gas Flame Control

An optimum flame will show a slight yellow tip. Prior to flame adjustment, operate furnace for at least fifteen minutes. Loosen air shutter set screws and move the air shutters away from the manifold to reduce the primary air until the yellow flame tips appear (see figure 11.2). Then increase the primary air until yellow tips diminish and a clean blue flame with a well defined inner cone appears.

It may also be necessary to adjust the manifold position in addition to adjusting air shutters to obtain proper flame. Follow the instructions under "Natural Gas Flame Control" for adjusting the manifold.

START-UP PROCEDURE

Table 11.1
Manifold Pressure & Gas Consumption ①

Model	BTU/Cu. Ft. Specific Gravity	Natural	Propane	No. of Orifices
		1050 0.60	2500 1.53	
Manifold Pressure In. W.C.		3.5	10.0	
PDP 30	CFH Gal/Hr. Propane Orifice Drill Size	28.6 — 38	12.0 .33 52	1
PDP 50 BDP 50	CFH Gal/Hr. Propane Orifice Drill Size	47.6 — 30	20.0 .55 45	1
PDP 75 BDP 75	CFH Gal/Hr. Propane Orifice Drill Size	71.4 — 21	30.0 .82 39	1
PDP 100 BDP 100	CFH Gal/Hr. Propane Orifice Drill Size	95.2 — 30	40.0 1.15 45	2
PDP 125 BDP 125	CFH Gal/Hr. Propane Orifice Drill Size	119.0 — 26	50.0 1.43 43	2
PDP 150 BDP 150	CFH Gal/Hr. Propane Orifice Drill Size	138.1 — 21	58.0 1.64 39	2
PDP 175 BDP 175	CFH Gal/Hr. Propane Orifice Drill Size	166.7 — 28	70.0 1.86 43	3
PDP 200 BDP 200	CFH Gal/Hr. Propane Orifice Drill Size	190.5 — 25	80.0 2.19 42	3
PDP 250 BDP 250	CFH Gal/Hr. Propane Orifice Drill Size	238.1 — 18	100.0 2.74 36	3
PDP 300 BDP 300	CFH Gal/Hr. Propane Orifice Drill Size	285.7 — 21	120.0 3.29 39	4
PDP 350 BDP 350	CFH Gal/Hr. Propane Orifice Drill Size	333.3 — 23	140.0 3.84 41	5
PDP 400	CFH Gal/Hr. Propane Orifice Drill Size	381.0 — 25	160.0 4.38 42	6

① Above gases based on average standards. Units can be furnished for gases of different values and specific gravities. (Gal./Hr. based on 60°F, 30" Hg., 91,500 BTU/Gal.) In Canada, refer to rating plate on side of unit for orifices at high altitude.

Figure 11.1
Manifold Adjustment, Natural Gas

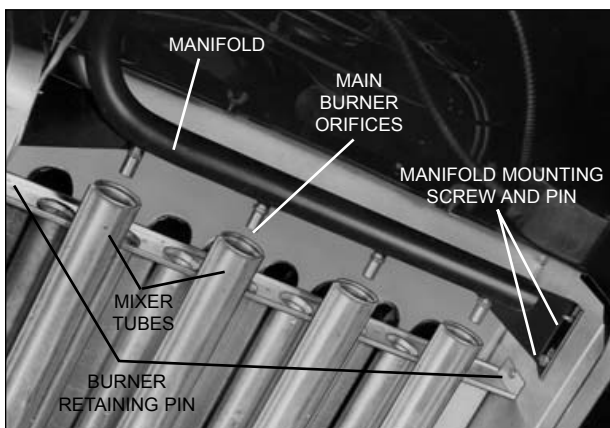
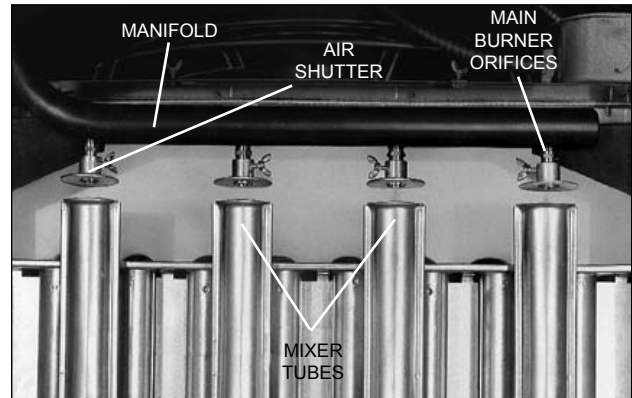

Figure 11.2 - Air Shutter Adjustment, Propane Gas



Control Operating Sequence

Unit heaters are supplied with standing pilot control systems as standard or intermittent pilot systems with continuous retry as an option. On standing pilot and mechanical modulation systems the main burner is turned off 100% when the thermostat is satisfied, but the pilot remains lit. For intermittent pilot systems, except mechanical modulation both the main burner and pilot burner are turned off 100% when the thermostat is satisfied. Standing pilot systems, for both natural and propane gas, have a manually lit pilot which stays lit until the gas valve is manually turned to the off position. On a call for heat, the gas valve opens, sending gas to the burner allowing the unit to fire. Intermittent pilot systems, for both natural and propane gas, the ignition controller is 100% shut-off with continuous retry. On a call for heat, the system will attempt to light the pilot for 70 seconds. If the pilot is not sensed for any reason, the ignition control will wait for approximately six minutes with the combination gas control closed and no spark. After six minutes, the cycle will begin again. After three cycles, some ignition controllers lockout for approximately one hour before the cycle begins again. This will continue indefinitely until the pilot flame is sensed or power is interrupted to the system. Refer to table 14.1 for control code descriptions.

NOTE: Gas Control Options could change the listed sequence of operation based on their function. The descriptions given are for the basic unit heater.

Single-Stage Gas Controls (standing pilot)

Utilizes a single-stage combination gas control with a standing pilot operator and a single-stage low voltage thermostat.

1. Pilot is lit continuously.
2. The thermostat calls for heat.
3. The power exhauster relay is energized starting the power exhauster motor. Once the motor has reached full speed, the differential pressure switch closes.
4. The main gas valve is opened and the main burner is lit to 100% full fire.
5. The air mover starts after 30 to 90 seconds.
6. The unit continues to operate until the thermostat is satisfied, at which time the main valve closes 100%.
7. The air mover stops after 30 to 90 seconds.

Single-Stage Gas Controls (intermittent pilot)

Utilizes a single-stage combination gas, an ignition control, and a single-stage low voltage thermostat.

1. The thermostat calls for heat.
2. The power exhauster relay is energized starting the power exhauster motor. Once the motor has reached full speed, the differential pressure switch closes.
3. The pilot valve opens and the spark ignitor sparks in an attempt to light the pilot.
4. Once the pilot is lit, the flame sensor proves the pilot and stops the spark ignitor from sparking.
5. The main gas valve is opened and the main burner is lit to 100% full fire.
6. The air mover starts after 30 to 90 seconds.
7. The unit continues to operate until the thermostat is satisfied, at which time both the main and pilot valves close 100%.
8. The air mover starts after 30 to 90 seconds.

START-UP PROCEDURE

Two-Stage Gas Controls (intermittent pilot)

Utilizes a two-stage combination gas control, an ignition control, and a two-stage low voltage thermostat. The unit fires at 50% fire on low stage and 100% fire on high stage.

1. The thermostat calls for low stage heat.
2. The power exhauster relay is energized starting the power exhauster motor. Once the motor has reached full speed, the differential pressure switch closes.
3. The pilot valve opens and the spark ignitor sparks in an attempt to light the pilot.
4. Once the pilot is lit, the flame sensor proves the pilot and stops the spark ignitor from sparking.

5. The main gas valve is opened and the main burner is lit to 50% fire.
6. The air mover starts after 30 to 90 seconds.
7. If the temperature at the thermostat continues to fall, the thermostat will call for high stage heat.
8. The main gas valve is opened completely and the main burner is lit to 100% full fire.
9. The unit continues to operate until the high stage of the thermostat is satisfied, at which time the main valve closes to 50% fire.
10. The air mover stops after 30 to 90 seconds.

Table 12.1

Propeller Unit Heaters – PDP Model

Control System Description	Control Code No.	Service Voltage	Thermostat Voltage	Type of Gas
Single-Stage, Standing Pilot, 100% Shut-Off – Utilizes a single-stage combination gas control and thermocouple. Pilot needs to be manually lit initially and stays lit.	11	115V	25V	natural natural propane propane
	12	200/230V	25V	
	81	115V	25V	
	82	200/230V	25V	
Single-Stage, Intermittent Pilot Ignition, 100% Shut-Off with Continuous Retry – Utilizes a single-stage combination gas control and an ignition control (continuous retry). Pilot is automatically lit on call for heat.	30	115V	25V	natural natural propane propane
	31	200/230V	25V	
	85	115V	25V	
	86	200/230V	25V	
Two-Stage, Intermittent Pilot Ignition, 100% Shut-Off with Continuous Retry – Utilizes a two-stage combination gas control (which fires at 50% or 100% of full rated input) and an ignition control (continuous retry). Pilot is automatically lit only on call for heat. Available on model sizes 50-400.	63	115V	25V	natural natural propane propane
	64	200/230V	25V	
	87	115V	25V	
	88	200/230V	25V	
Mechanical Modulation with Automatic Pilot Ignition, 100% Shut-Off with Continuous Retry – Utilizes a modulating combination gas control and an ignition control (continuous retry). Pilot is automatically lit whenever there is power to the unit. Modulation range is between 50% and 100% fire; gas control shuts off below 50% fire. Available on blower models only.	59	115V	25V	natural natural propane propane
	60	200/230V	25V	
	89	115V	25V	
	90	200/230V	25V	

OPTIONS

Figure 13.1
Factory Mounted Option Location

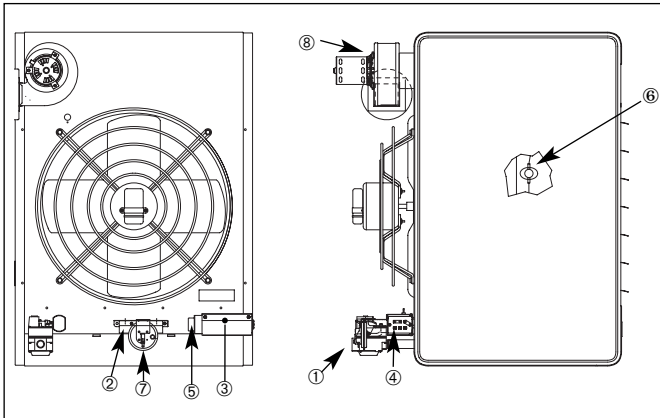

All units include the standard (STD) features. The unit must be reviewed to determine the optional (OPT) features that may have been supplied with the unit.

(1) Gas Valve

a) Single Stage Gas Valve - (STD)

The main gas valve is factory installed on the unit heater gas train. The main gas valve provides the pilot, regulator, main gas, and manual shutoff functions. For additional information, see the supplier literature included with the unit.

b) Two Stage Gas Valve - (OPT)

The two-stage gas valve is factory installed on the unit heater gas train. The two stage gas valve provides the pilot, regulator, main gas (100% and 50% fire), and manual shutoff functions. For additional information, see the supplier literature included with the unit.

(2) Ignition controller - (OPT)

The ignition controller is factory installed on the back of the unit heater with the spark igniter and sensor located on the burner.

For both natural and propane gas units, the ignition controller is 100% shut-off with continuous retry. On a call for heat, the system will attempt to light the pilot for 70 seconds. If the pilot is not sensed for any reason, the ignition control will wait for approximately six minutes with the combination gas control closed and no spark. After six minutes, the cycle will begin again. After three cycles, some ignition controllers lockout for approximately one hour before the cycle begins again. This will continue indefinitely until the pilot flame is sensed or power is interrupted to the system.

(3) Time Delay Relay - (STD)

The time delay relay is factory installed in electrical junction box. The time delay relay allows the gas controls to operate

for approximately 30 to 90 seconds before the blower starts. This allows the heat exchanger a warm up period so that the initial delivered air is not cool. The time delay relay also keeps the motor running for approximately 30 - 90 seconds after the call for heat has been satisfied to remove the residual heat from the heat exchanger. For single-phase units below 2 Hp, the time delay relay controls the motor directly. For single-phase units 2 Hp and greater and all three phase units, the time delay relay controls the motor starter.

(4) Low Voltage Terminal Board - (STD)

The low voltage terminal board is located in electrical junction box. The terminal board is labeled to match the electrical wiring diagram provided with the unit. All low voltage field wiring connections should be made to the exposed side of the terminal board (exterior of electrical junction box) to prevent miswiring by modifying the factory wiring which is inside the electrical junction box.

(5) Control Step Down Transformer - (STD)

The control step down transformer is located in the electrical junction box. The transformer is used to step down the supply power (115V, 208V, 230V, 460V, 575V) to 24V. This transformer is used to control the gas controls, fan delay relay, field Supplied motor starter, etc. All unit heaters are supplied with a 40VA control step down transformer. To determine the control transformer supplied as well as any accessory/ field supplied transformers required reference the supply voltage listed on the serial plate and reference tables 16.1 and 16.2.

(6) High Limit Switch - (STD)

The automatic reset high limit switch is factory installed on the left side (air blowing you in the face) of the unit heater. If the limit temperature is exceeded, the gas controls are de-energized until the switch is cooled.

(7) Pressure Switch (STD)

A automatic reset vent pressure switch is supplied on all Power vented unit heaters and is designed to prevent operation of the main burner in the event there is restricted venting of flue products. This restriction may occur due to an improper vent diameter, long vent runs, un-approved vent terminal, high winds, high negative pressure within space, etc. After the cause of the restriction has been corrected, the pressure switch will reset automatically. See trouble shooting section for more information.

(8) Power Exhauster (STD)

All power vented unit heaters are supplied with a round vent pipe connection. Some models may require the use of a vent transition from the power exhauster outlet to the vent pipe (See table 6.1). The power exhauster may be rotated 180° to allow for various venting directions.

Table 13.1
Electrical Details Propeller Units

Power				Control Code Selected	Factory Installed Transformer	Additional Field Installed Transformers
Building Supply Voltage		Unit Power (As found on Serial Plate)				
Voltage	Phase	Voltage	Phase			
115	1	115	1	11,25,30,59,63,81,83,85,87,89	115 to 24	none
200-208	1	115	1	11,25,30,59,63,81,83,85,87,89	115 to 24	208V to 115V
200-208	1	200-208	1	12,26,31,60,64,82,84,86,88,90	200-208 to 24	none
200-208	3	115	1	11,25,30,59,63,81,83,85,87,89	115 to 24	208V to 115V ①
230	1	115	1	11,25,30,59,63,81,83,85,87,89	115 to 24	208 to 115V ①
230	1	230	1	12,26,31,60,64,82,84,86,88,90	230 to 24	none
230	3	115	1	11,25,30,59,63,81,83,85,87,89	115 to 24	230V to 115V ①
460	3	115	1	11,25,30,59,63,81,83,85,87,89	115 to 24	460 to 115V
575	3	115	1	11,25,30,59,63,81,83,85,87,89	115 to 24	575 to 115V

① A transformer may not be required. 115V/1 ϕ power may be obtained from the following electrical distribution systems: 230/1 ϕ 3-wire, 230/3 ϕ 4-wire, 208/3 ϕ 4-wire and 208/1 ϕ 3-wire (from 208V wye connected transformer). Please consult the job site electrician to determine applicability.

GENERAL PERFORMANCE DATA

Table 14.1 - Performance — Propeller Models ① ②

Standard	Model Number												
	PDP 30	PDP 50	PDP 75	PDP 100	PDP 125	PDP 150	PDP 175	PDP 200	PDP 250	PDP 300	PDP 350	PDP 400	
Btu/Hr. Input	30,000	50,000	75,000	100,000	125,000	150,000	175,000	200,000	250,000	300,000	350,000	400,000	
Btu/Hr. Output	24,000	40,000	60,000	80,000	100,000	120,000	140,000	160,000	200,000	240,000	280,000	320,000	
Entering Airflow (CFM)	440	740	1100	1460	1850	2180	2550	2870	3700	4460	4870	5440	
Outlet Velocity	515	610	736	860	870	931	959	819	1053	1123	1068	1016	
Air Temp. Rise (°F)	51	50	51	51	50	51	51	52	50	50	53	54	
Max. Mounting Hgt. (Ft) ③	7	9	12	14	14	16	17	15	19	21	20	19	
Heat Throw (Ft) ③ (Max. Mtg. Hgt.)	25	33	41	49	51	55	59	51	67	74	70	69	
Motor Type	SP	SP	PSC	PSC	PSC	PSC	PSC	PSC	PSC	PSC	PSC	PSC	
HP	115/60/1 (PC01)	1/40	1/40	1/12	1/12	1/8	1/8	1/6	1/6	1/3	1/2	3/4	3/4
	230/60/1 (PC02)	1/40	1/40	1/8	1/8	1/8	1/8	1/6	1/6	1/3	1/2	3/4	3/4
	200-208/60/1 (PC03)	1/40	1/40	1/8	1/8	1/8	1/8	1/6	1/6	1/3	1/2	3/4	3/4

Table 14.2 - Motor Data and Total Unit Power Requirements — Propeller Models ①

Unit Voltage	115/60/1				115/60/1 With Use of Transformer								208/60/1				230/60/1			
Supply Voltage	115/60/1				208V		230V		460V		575V		208/60/1				230/60/1			
HP	Mtr. Amps	Mtr. Rpm	Total Amps	Max Watts	KVA Req.	Total Amps	KVA Req.	Total Amps	KVA Req.	Total Amps	KVA Req.	Total Amps	Mtr. Amps	Mtr. Rpm	Total Amps	Max Watts	Mtr. Amps	Mtr. RPM	Total Amps	Max Watts
1/40	1.0	1550	2.7	320	0.50	2.4	0.50	2.17	0.50	1.09	0.50	0.87	0.4	1550	1.3	270	0.4	1550	1.3	300
1/12	1.6	1625	3.3	400	0.50	2.4	0.50	2.17	0.50	1.09	0.50	0.87	---	---	---	---	---	---	---	---
1/8	2.3	1625	4.0	480	0.50	2.4	0.50	2.17	0.50	1.09	0.50	0.87	1.0	1625	1.9	400	1.0	1625	1.9	440
1/6	2.7	1075	5.1	610	1.00	4.81	0.75	3.26	0.75	1.63	0.75	1.30	1.5	1075	2.8	580	1.5	1075	2.8	640
1/3	5.4	1075	7.7	890	1.00	4.81	1.00	4.35	1.00	2.17	1.00	1.74	---	---	---	---	2.5	1075	3.7	840
1/2	7.5	1075	9.8	1180	1.50	7.2	1.50	6.52	1.50	3.26	1.50	2.61	---	---	---	---	3.5	1075	4.7	1070
3/4	8.8	1125	11.1	1330	1.50	7.2	1.50	6.52	1.50	3.26	1.50	2.61	---	---	---	---	4.4	1125	5.5	1280

- ① All motors used are produced, rated and tested by reputable manufacturers in accordance with NEMA standards and carry the standard warranty of both the motor manufacturer and Modine. All motors are totally enclosed and all single phase motors have built-in thermal overload protection.
- ② Ratings shown are for elevations up to 2,000 ft. For elevations above 2,000 feet, ratings should be reduced at the rate of 4% for each 1,000 feet above sea level. (In Canada see rating plate.) Reduction of ratings requires use of a high altitude kit.
- ③ Data taken at 55°F air temperature rise. At 65°F ambient and unit fired at full-rated input. Mounting height as measured from bottom of unit, and without deflector hood.

Table 14.3 - Performance Data - 30°, 60°, and 90° Downward Deflector Hoods

Hood Type	Model Size	Model Size											
		50	75	100	125	150	175	200	250	300	350	400	
30°	Max. MTG. HGT.	12	14	16	18	18	18	18	22	24	24	24	
	X	4	5	5	6	6	9	6	8	8	8	8	
	Y	12	14	17	18	20	26	18	24	26	24	24	
	Z	17	21	25	26	29	37	26	35	38	36	35	
60°	Max. MTG. HGT.	10	14	16	18	18	18	18	22	24	24	24	
	X	0	0	0	0	0	0	0	0	0	0	0	
	Y	14	10	13	12	13	23	12	16	19	16	16	
	Z	19	14	19	17	19	32	17	23	28	24	23	
90°	Max. MTG. HGT.	12	16	20	20	22	22	22	28	30	30	30	
	S	12	16	19	21	23	25	22	29	32	20	29	

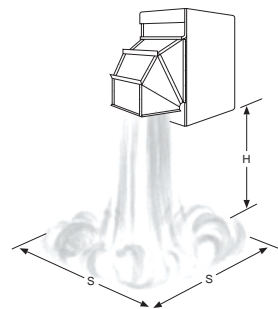

NOTE:
 X = FEED FROM HEATER TO START OF FLOOR COVERAGE.
 Y = FEET TO END OF FLOOR COVERAGE.
 Z = FEET TO END OF THROW.

- ② Data Based on unit fired at full rated input, 60° - 80°F entering air temperature, and a 40°F temperature rise through unit. Maximum mounting heights higher versus units without outlet devices.

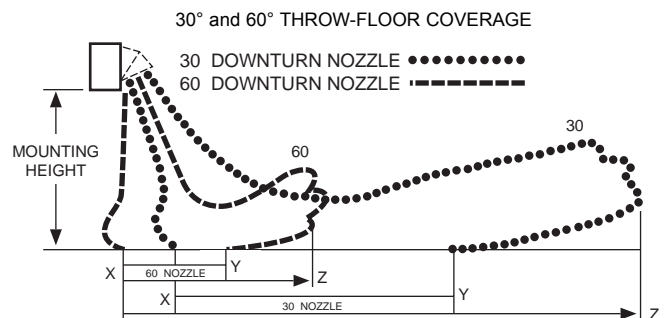
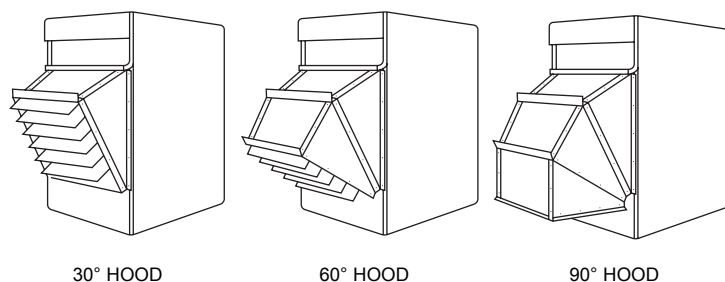

DIMENSIONAL DATA

Propeller Units - Model PDP

Figure 15.1

Dimensional Drawings

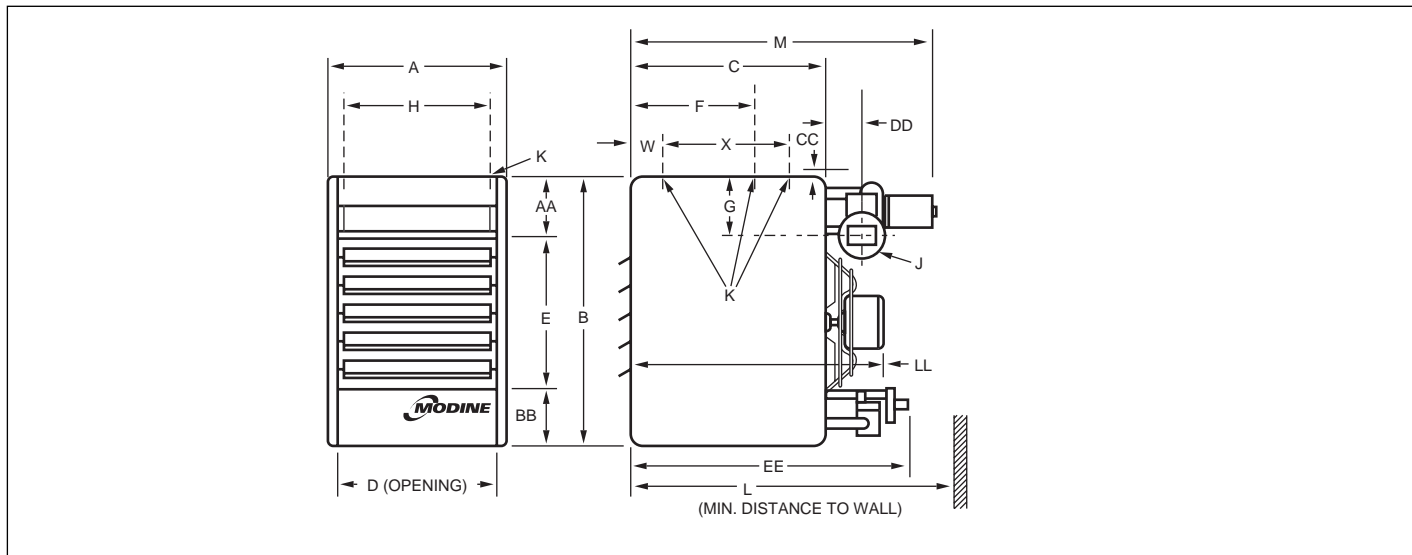

Table 15.1
Dimensions (inches) — PDP ①

Dimension Symbol	Model Number											
	PDP 30	PDP 50	PDP 75	PDP 100	PDP 125	PDP 150	PDP 175	PDP 200	PDP 250	PDP 300	PDP 350	PDP 400
A	12-7/8	17-1/4	17-1/4	19-1/4	19-1/4	21	23-1/2	25-5/8	25-5/8	28-5/8	33-5/8	40
B	24-1/4	24-1/4	28-3/4	28-3/4	35-1/4	35-1/4	35-1/4	40-1/4	40-1/4	40-1/4	40-1/4	40-1/4
C	14-3/4	14-3/4	20	20	22	22	22	25	25	25	25	25
D	10-7/16	14-13/16	14-13/16	16-13/16	16-13/16	18-9/16	21-1/16	23-3/16	23-3/16	26-3/16	31-3/16	37-1/2
E	13	13	16	16	20	20	20	24	24	24	24	24
F	9-1/4	9-1/4	11	11	12	12	12	13-1/2	13-1/2	14	—	—
G	5-1/2	5-1/16	5-11/16	5-11/16	7-5/8	6-9/16	6-9/16	7-1/2	7-1/2	7-1/2	7-1/2	7-1/2
H	9-1/4	13-5/8	13-5/8	15-5/8	15-5/8	17-3/8	19-7/8	22	22	25	30	36-3/8
J ②	3 or 4	3 or 4	4	4	4	5	5	5	6	6	6	6
K (Mounting Holes) ③	3/8-16	3/8-16	3/8-16	3/8-16	3/8-16	3/8-16	3/8-16	3/8-16	3/8-16	3/8-16	3/8-16	3/8-16
L ④	28-7/16	30-3/8	33-1/16	33	36-3/4	35-13/16	35-9/16	40-3/4	40-3/4	40-3/4	40-3/4	44-3/16
M	22-7/16	24-3/8	27-1/16	27	30-3/4	29-13/16	29-9/16	34-3/4	34-3/4	34-3/4	34-11/16	38-3/16
W	—	—	—	—	—	—	—	—	—	—	5	5
X	—	—	—	—	—	—	—	—	—	—	16	16
AA	5	5	6-1/4	6-1/4	8	8	8	9	9	9	9	9
BB	6-1/4	6-1/4	6-1/2	6-1/2	7-1/4	7-1/4	7-1/4	7-1/4	7-1/4	7-1/4	7-1/4	7-1/4
CC	11/16	1-1/8	5/8	5/8	—	—	—	—	—	—	—	—
DD	2-5/8	4-9/16	2	2	2-3/4	2-3/4	2-3/4	3-3/8	3-3/8	3-3/8	3-3/8	6-13/16
EE	22-1/4	22-1/4	29	29	30-1/2	30-1/2	30-1/2	32-7/8	32-7/8	32-7/8	32-7/8	32-7/8
LL	19-1/2	20-1/8	30	30	30	31-1/8	31-1/8	34-7/8	34-7/8	36-1/4	35-1/2	40-1/2
Gas Connections ⑤	1/2	1/2	1/2	1/2	1/2	1/2	1/2	1/2	1/2	1/2	3/4	3/4
Fan Diameter	9	12	12	14	14	16	18	20	20	22	22	24
Approx. Weight	64	78	108	122	162	168	175	239	239	269	338	418

① Do not use propeller units with duct work.

② Diameter of round vent pipe to fit oval opening.

③ PDP 30 through PDP 300 — 2 holes (and the level hanging adjustment feature). PDP 350 through PDP 400 — 4 holes. (Listed is the hole diameter and threads per inch to accept threaded rod).

④ Dimension equals overall plus 6".

⑤ For natural gas; may vary depending on control availability.

MAINTENANCE

All heating equipment should be serviced before each heating season to assure proper operations. The following items may be required to have more frequent service schedule based on the environment in which the unit is installed, and the frequency of the equipment operation.

General Unit

When providing annual maintenance for the unit heater, keep the unit free from dust, dirt, grease and foreign matter. Pay particular attention to:

1. The combustion air and exhaust vent piping.
2. The burner ports and pilot burner orifices (avoid the use of hard, sharp instruments capable of damaging surfaces for cleaning these ports). To check the burner port and pilot burner orifice, see Burner and Pilot Assembly Removal.
3. The air shutters and main burner orifices (avoid the use of hard, sharp instruments capable of damaging surfaces for cleaning these orifices). To check the air shutters and main burner orifices, see for Manifold Assembly Removal.
4. The heat exchanger. Clean tubes from the bottom with a stiff non-wire brush.
5. The heat exchanger should be checked annually for cracks and discoloration of the tubes. If a crack is detected, the heat exchanger should be replaced before the unit is put back into service. If the tubes are dark gray, airflow across the heat exchanger should be checked to insure that a blockage has not occurred or the blower is operating properly.

Electrical Wiring

The electrical wiring should be checked annually for loose connections or deteriorated insulation.

Gas Piping & Controls

The gas valves and piping should be checked annually for general cleanliness and tightness.

The gas controls should be checked to insure that the unit is operating properly.

Propeller Assembly

Check the motor for lubrication if the motor is not permanently lubricated. Inspect the fan for damage and fit on motor shaft. Clean any dust, dirt or foreign matter from the fan blades.

Manifold Assembly Removal

To remove the manifold

1. Shut off gas and electric supply.
2. Lower bottom pan to expose burner and manifold (see fig. 11.1)
3. Disconnect pilot tubing and thermocouple lead (or ignition cable) at the combination gas control (and ignition control).
4. Disconnect control wires for the combination gas control.
5. Disconnect gas manifold at ground union joint.
6. Remove the two screws holding the manifold to the heat exchanger support.
7. Clean the orifices and adjust the air shutters as necessary.
8. Follow steps 2-6 in reverse order to install the manifold assembly.
9. Turn on the electric and gas supply.

10. Check the ground union joint for leaks with a soap solution. Tighten if necessary.

Burner and Pilot Assembly Removal

To remove the burner

1. Shut off gas and electric supply.
2. Lower bottom pan to expose burner and manifold (see fig. 11.1)
3. Disconnect pilot tubing and thermocouple lead (or ignition cable) at the combination gas control (and ignition control).
4. Remove the two burner retaining pins holding the burner in place. The burner can then be easily lowered from the unit.
5. Examine the burner and pilot assembly for cleanliness and/or obstructions as necessary (see General Unit for cleaning instructions).
6. Replace the burner assembly in reverse order. In replacing the burner, be certain that the slots at the front of the burner are located properly on their shoulder rivets and that the burner retaining pins are put back into their proper locations.
8. Reconnect the ignition cable and pilot gas supply line.
9. Turn on the electric and gas supply.

SERVICE & TROUBLESHOOTING

! WARNING

When servicing or repairing this equipment, use only factory-approved service replacement parts. A complete replacement parts list may be obtained by contacting Modine Manufacturing Company. Refer to the rating plate on the appliance for complete appliance model number, serial number, and company address. Any substitution of parts or controls not approved by the factory will be at the owner's risk.

! CAUTION

Do not attempt to reuse any mechanical or electrical controllers which have been wet. Replace defective controller.

IMPORTANT

To check most of the Possible Remedies in the troubleshooting guide listed in Table 17.1, refer to the applicable sections of the manual.

Table 17.1
Troubleshooting

Trouble	Possible Cause	Possible Remedy
Pilot does not light	<ol style="list-style-type: none"> 1. Main gas is off. 2. Power supply is off. 3. Air in gas line. 4. Dirt in pilot orifice. 5. Gas pressure out of proper range. 6. Pilot valve does not open. <ol style="list-style-type: none"> a. Defective ignition controller. b. Defective gas valve. 7. No Spark at ignitor. <ol style="list-style-type: none"> a. Loose wire connections. b. Pilot sensor is grounded. c. Defective ignition controller. 8. Safety device has cut power. 9. Pilot valve is off. 10. Dirty thermocouple contact. 11. Excessive drafts. 12. Pilot orifice Fitting leak. 	<ol style="list-style-type: none"> 1. Open manual gas valve. 2. Turn on main power. 3. Purge gas line. 4. Check for plugged pilot orifice and clean with compressed air if necessary. 5. Adjust to a maximum of 14" W.C. Minimum for Natural Gas - 6" W.C. Minimum for Propane Gas - 11" W.C. 6. Check wiring for 24 volts to valve. <ol style="list-style-type: none"> a. Replace ignition controller. b. Replace gas valve. 7. <ol style="list-style-type: none"> a. Check all ignition controller wiring. b. Replace sensor if cracked or worn c. Replace ignition controller. 8. Check all safety devices (High limit, pressure switch, blocked vent safety switch, etc.) Determine and correct problem. Reset if necessary. 9. Turn gas control knob or lever on combination gas control to pilot position. 10. Be sure thermocouple contact is clean. If problem persists replace thermocouple. 11. Find source and re-direct airflow away from unit. 12. Tighten pilot orifice. Flame impingement on thermocouple may cause thermocouple to become inoperative.
Main burners do not light (Pilot is lit)	<ol style="list-style-type: none"> 1. Defective valve. 2. Loose wiring. 3. Defective pilot sensor 4. Defective ignition controller. 5. Improper thermostat wiring. 	<ol style="list-style-type: none"> 1. Replace valve. 2. Check wiring to gas valve. 3. Replace pilot sensor. 4. Replace ignition controller. 5. Verify wiring compared to wiring diagram.
Lifting Flames (See Figure 18.2)	<ol style="list-style-type: none"> 1. Too much primary air. 2. Main pressure set too high. 3. Orifice too large. 	<ol style="list-style-type: none"> 1. Reduce primary air. 2. Adjust to a maximum of 14" W.C. 3. Check orifice size with those listed on the serial plate.
Yellow Tipping (With propane gas, some yellow tipping is always present.)	<ol style="list-style-type: none"> 1. Insufficient primary air. 2. Dirty orifice. 3. Misaligned orifice. 	<ol style="list-style-type: none"> 1. Increase primary air. 2. Check orifices and clean with compressed air if necessary. 3. Check manifold, replace if necessary.
Wavering Flames (See Figure 18.1)	<ol style="list-style-type: none"> 1. Drafts across burner 2. Misalignment of burner 3. Cracked heat exchanger 	<ol style="list-style-type: none"> 1. Eliminate drafts 2. Align burner on locator pins 3. Replace heat exchanger

SERVICE & TROUBLESHOOTING

Trouble	Possible Cause	Possible Remedy
Flashback	<ol style="list-style-type: none"> 1. Too much primary air 2. Main pressure set too high. 3. Orifice too large. 	<ol style="list-style-type: none"> 1. Reduce primary air. 2. Adjust to maximum of 14" W.C. 3. Check orifice size with those listed on the serial plate.
Floating Flames (See Figure 18.3)	<ol style="list-style-type: none"> 1. Insufficient primary air. 2. Main pressure set too high. 3. Orifice too large. 4. Blocked vent. 	<ol style="list-style-type: none"> 1. Increase primary air. 2. Adjust to a maximum of 14" W.C. 3. Check orifice size with those listed on the serial plate. 4. Clean/correct venting system.
Flame Rollout (See Figure 18.4)	<ol style="list-style-type: none"> 1. Main pressure set too high. 2. Orifice too large. 3. Blocked vent. 	<ol style="list-style-type: none"> 1. Adjust to a maximum of 14" W.C. 2. Check orifice size with those listed on the serial plate. 3. Clean/correct venting system.
Not Enough Heat	<ol style="list-style-type: none"> 1. Unit cycling on high limit. ① <ol style="list-style-type: none"> a. Obstructions/leaks in duct system. b. Main pressure set too high. c. Blower motor not energized. d. Loose belt e. Blower speed too low. f. Blocked/damaged venting system. g. Air distribution baffle removed (high temperature rise units only). h. Defective high limit switch. 2. Main pressure set too low. 3. Too much outside air. 4. Thermostat malfunction. 5. Gas controls wired incorrectly. 6. Unit undersized. 	<ol style="list-style-type: none"> 1. <ol style="list-style-type: none"> a. Clean/correct duct system. b. Adjust to a maximum of 14" W.C. c. Check/correct to insure blower motor operates within 45 seconds of when gas controls are energized. d. Adjust belt tension. e. Check/correct blower drive settings for proper rpm. f. Check/correct venting system. g. Replace air distribution baffle. h. Replace high limit switch. 2. Adjust main gas pressure. Minimum for Natural Gas — 6" W.C. Minimum for Propane Gas — 11" W.C. 3. Adjust outside air damper to decrease outside air percentage (if possible). 4. Check/replace thermostat. 5. Check unit wiring against the wiring diagram. 6. Check design conditions. If unit is undersized, an additional unit(s) or other heat source must be added.
Too Much Heat	<ol style="list-style-type: none"> 1. Thermostat malfunction. 2. Gas controls do not shut-off. <ol style="list-style-type: none"> a. Gas controls wired incorrectly. b. Short circuit. 3. Main gas pressure set too high. 4. Defective gas valve. 	<ol style="list-style-type: none"> 1. Check/replace thermostat. 2. <ol style="list-style-type: none"> a. Check unit wiring against the wiring diagram. b. Check for loose or worn wires. 3. Adjust to a maximum of 14" W.C. 4. Replace gas valve.

① Automatic Reset High Limit

The unit heater comes standard with an automatic reset high limit switch that will shut-off the gas should the discharge air temperature become excessive. See Figure 15.1, indicator ⑦ for the location of either the standard automatic high limit switch. The switch should operate only when something is seriously wrong with the unit operation. Anytime the switch operates, correct the difficulty immediately or serious damage may result. If the switch cuts off the gas supply during normal operation, refer to the "Not Enough Heat" section of Service & Troubleshooting.

Figure 18.1
Wavering Flame or Misalignment

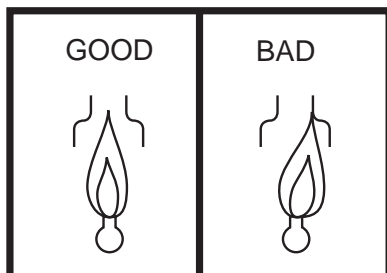

Figure 18.2
Lifting Flame Condition

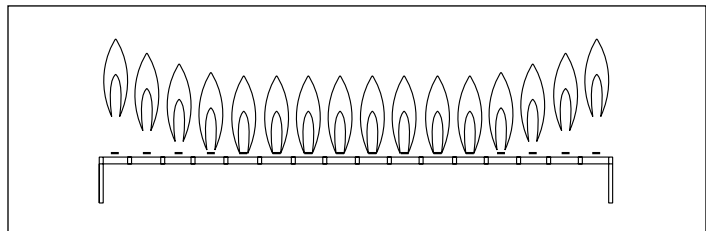

Figure 18.3
Floating Flame Condition

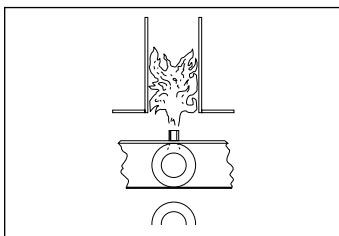
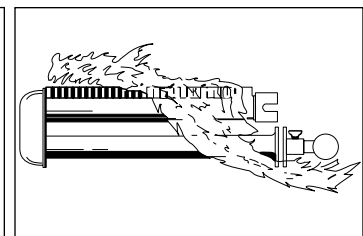

Figure 18.4
Flame Rollout Appearance



RATING PLATE IDENTIFICATION

Figure 19.1 - Serial Number Designations

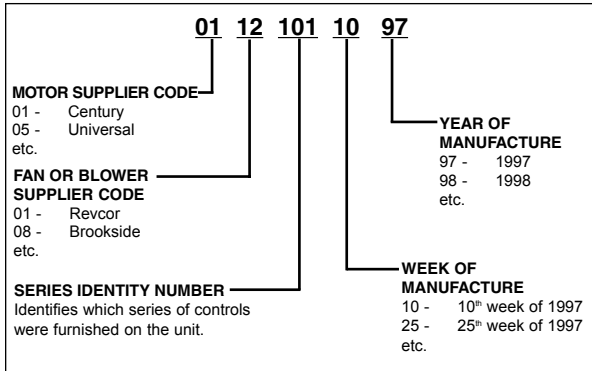

Figure 19.2 - Model Number Designations

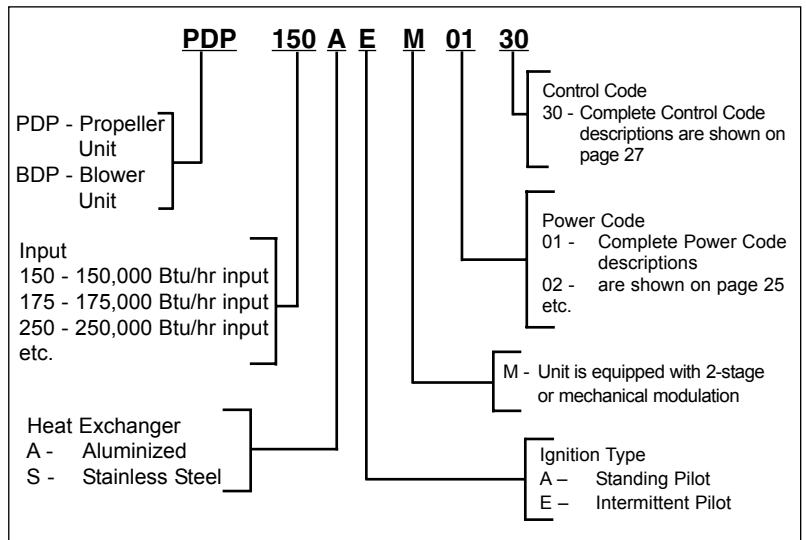

Figure 19.3 Serial Plate

Modine Manufacturing Company
1221 Magnolia Ave., Buena Vista, VA 24416
Phone: 800-828-4328

UNIT HEATER FOR INDUSTRIAL / COMMERCIAL USE
AÉROTHERME POUR USAGE INDUSTRIEL / COMMERCIAL

Made in U.S.A.

MODEL NUMBER NUMERO DE MODELE PDP200AA0111		MIN. INPUT BTU/HR DEBIT CALORIFIQUE MIN. BTU/HEURE		VOLTS 115	AMPS 3.1	PHASE 1	HERTZ 60
SERIAL NUMBER NUMERO DE SERIE 15201022498-0045		MIN. INLET PRESS. FOR PURPOSE OF INPUT ADJUSTMENT / PRESSION D'ALIMENTATION EN GAZ MIN. ADMISE 6 IN M.C. PO.CO'E		CATEGORY CATEGORIE I		DESIGN COMPLIES WITH UNIT HEATER STANDARD: ANSI Z83.8b-2000 CGA 2.6b-M00	
TYPE OF GAS TYPE OF GAZ Natural		MANIFOLD PRESSURE PRESSION A LA TUEULURE D'ALIMENTATION 3.5 IN M.C. PO.CO'E		APPROVALS ACCEPTED BY CITY OF NEW YORK: MEA 293-96-E PENNSYLVANIA APPROVAL NO. 3465 APPROVED FOR USE IN MASSACHUSETTS APPROVED FOR USE IN CA BY THE CEC WHEN EQUIPPED WITH IPT			
MAXIMUM EXTERNAL STATIC PRESSURE PRESSION STATIQUE EXTERIEUR MAXIMUM 0.0 IN M.C. PO.CO'E		MINIMUM CLEARANCE TO COMBUSTIBLE MATERIAL DÉGAGEMENT MINIMUM POUR MATIÈRES COMBUSTIBLES					
INPUT BTU/HR DEBIT CALORIFIQUE BTU/HEURE	0 TO 2000 FT. 0 ET 610 M.	(IN CANADA) 2000 TO 4600 FT. 610 ET 1370 M.	TOP HAUT 2 IN PO.	RIGHT SIDE CÔTÉ DROIT 18 IN PO.	SERIES UNIT HEATER IS FOR USE WITH DUCTS AT A TEMPERATURE RISE RANGE / SÉRIE AÉROTHERME FONCTIONNE AVEC DES CONDUITS A UNE ÉLEVATION DE TEMPÉRATURE DE		
OUTPUT BTU/HR REDEMENT BTU/HEURE	200000	180000	BOTTOM BAS 12 IN PO.	VENT CONNECTOR CONNECTEUR D'AÉRATION 3 IN PO.			
ORIFICE SIZE DIM. DE L'INJECTEUR	25	27	LEFT SIDE CÔTÉ GAUCHE 18 IN PO.	X			
GENERAL							
<p>(IN USA) FOR INSTALLATIONS ABOVE 2000 FEET, DERATE 4 PERCENT FOR EACH 1000 FEET OF ELEVATION ABOVE SEA LEVEL. LUBRICATE MOTOR EVERY 2000 HOURS OF OPERATION WITH SAE #20 OIL. FILTERS, WHEN USED ON BLOWER UNIT HEATERS, MUST BE INSTALLED EXTERNAL TO THE HEATER CASING. PROPELLER UNIT HEATERS ARE NOT FOR USE WITH FILTERS. INSTALLATIONS IN AIRCRAFT HANGARS, PARKING STRUCTURES, AND REPAIR GARAGES SHALL BE IN ACCORDANCE WITH THE STANDARD ON AIRCRAFT HANGARS, ANSI/NFPA 409, THE STANDARD FOR PARKING STRUCTURES, ANSI/NFPA 88A, THE STANDARD FOR REPAIR GARAGES, ANSI/NFPA 88B, AND IN CANADA WITH THE CAN1-8149 CODES.</p>				<p>FOR UNITS WITH INTERMITTENT PILOT</p> <ol style="list-style-type: none"> SET THERMOSTAT TO LOWEST SETTING. MOVE GAS CONTROL KNOB (OR LEVER) TO OFF AND WAIT 5 MINUTES. MOVE GAS CONTROL KNOB (OR LEVER) TO ON. SET THERMOSTAT TO DESIRED SETTING. (PILOT AND MAIN BURNER WILL LIGHT AUTOMATICALLY WHEN THERMOSTAT CALLS FOR HEAT.) 		<p>FOR UNITS WITH STANDING PILOT</p> <ol style="list-style-type: none"> SET THERMOSTAT TO LOWEST SETTING. MOVE GAS CONTROL KNOB (OR LEVER) TO OFF AND WAIT 5 MINUTES. MOVE GAS CONTROL KNOB TO PILOT (OR MOVE GAS CONTROL LEVER TO SET) AND DEPRESS RESET BUTTON WHILE LIGHTING THE PILOT AND HOLD FOR 1 MINUTE AFTER PILOT IS LIT. MOVE GAS CONTROL KNOB (OR LEVER) TO ON. SET THERMOSTAT TO DESIRED SETTING. 	
SHUT DOWN INSTRUCTIONS: TURN OFF POWER & CLOSE ALL GAS VALVES.							
GENERAL							
<p>TOUTES LES 2000 HEURES DE FONCTIONNEMENT LUBRIFIER LE MOTEUR AVEC DE L'HUILE SAE N° 20. LORSQU'ILS SONT UTILISÉS SUR LES APPAREILS DE CHAUFFAGE À SOUFFLANTE LES FILTRES DOIVENT ÊTRE INSTALLÉS À L'EXTÉRIEUR DU BOUTIER DE L'APPAREIL. NE PAS UTILISER DE FILTRES AVEC LES APPAREILS DE CHAUFFAGE À PROPULSION. L'INSTALLATIONS DANS LES HANGARS D'AVIONS DOIT CONFORMER AUX EXIGENCES DES AUTORITÉS COMPÉTENTES, ET DANS LES GARAGES PUBLICS DOIT CONFORMER AUX CODES CAN 1-8149.</p>				<p>POUR UNITE ÉQUIPEE D'UNE VEILLEUSE INTERMITTENTE</p> <ol style="list-style-type: none"> RÉGLER LE THERMOSTAT SUR LE DEGRÉ LE PLUS BAS. TOURNER LA MOLETTE (OU LE LEVIER) DE COMMANDE DU GAZ SUR OFF ET ATTENDRE 5 MINUTES. TOURNER LA MOLETTE (OU LE LEVIER) DE COMMANDE DU GAZ SUR ON. LA VEILLEUSE ET LE BRÂLEUR PRINCIPAL S'ALLUMERONT AUTOMATIQUÉMENT QUAND LE THERMOSTAT LES DÉCLANCHERA. 		<p>POUR UNITE EQUIPEE D'UNE VEILLEUSE PERMANENTE</p> <ol style="list-style-type: none"> RÉGLER LE THERMOSTAT SUR LE DEGRÉ LE PLUS BAS. TOURNER LA MOLETTE (OU LE LEVIER) DE COMMANDE DU GAZ SUR OFF ET ATTENDRE 5 MINUTES. TOURNER LA MOLETTE DE COMMANDE DU GAZ SUR PILOT (OU TOURNER LE LEVIER DE COMMANDE SUR SET) ET, TOUT EN ALLUMANT LA VEILLEUSE, APPUYER SUR LE BOUTON DE RÉENCLANCHEMENT ET LE MAINTENIR ENFONCÉ PENDANT 1 MINUTE APRÈS ALLUMAGE DE LA TOURNER LA MOLETTE (OU LE LEVIER) DE COMMANDE DU GAZ SUR ON. RÉGLER LE THERMOSTAT SUR LE DEGRÉ DÉSIÉ. 	
INSTRUCTIONS DE FER METURE - COUPER LE COURANT ET FERMER TOUTES LES ROBINETS A GAZ.							
COMMON REPLACEMENT PARTS				Combination Gas Control 5H73117B1		24V Control Transformer 5H71956B1	
For parts ordering, contact the parts wholesaler or the manufacturer's representative serving your area.				Ignition Control None		Main Burner 3H33073B7	
When inquiring about parts, always provide model number, serial number, description, and part number. When ordering parts, provide part number listed.				Pressure Switch None		Fan/Blower Motor 9F30095	
For service, contact your local qualified installation and service contractor or appropriate utility company.				Limit Control 5H73593		Belts (Blower) None	
5H7373 Rev. B				Time Delay Relay 5H73035		Thermocouple 5H69336B6	
				Heat Exchanger 3H34721B15		Wiring Diagram 5H73095C2	

WARRANTY

Seller warrants its products to be free from defects in material and workmanship, EXCLUSIVE, HOWEVER, of failures attributable to the use of materials substituted under emergency conditions for materials normally employed. This warranty covers replacement of any parts furnished from the factory of Seller, but does not cover labor of any kind and materials not furnished by Seller, or any charges for any such labor or materials, whether such labor, materials or charges thereon are due to replacement of parts, adjustments, repairs, or any other work done. This warranty does not apply to any equipment which shall have been repaired or altered outside the factory of Seller in any way so as, in the judgment of Seller, to affect its stability, nor which has been subjected to misuse, negligence, or operating conditions in excess of those for which such equipment was designed. This warranty does not cover the effects of physical or chemical properties of water or steam or other liquids or gases used in the equipment.

BUYER AGREES THAT SELLER'S WARRANTY OF ITS PRODUCTS TO BE FREE FROM DEFECT IN MATERIAL AND WORKMANSHIP, AS LIMITED HEREIN, SHALL BE IN LIEU OF AND EXCLUSIVE OF ALL OTHER WARRANTIES, EITHER EXPRESS OR IMPLIED, WHETHER ARISING FROM LAW, COURSE OF DEALING, USAGE OF TRADE, OR OTHERWISE, **THERE ARE NO OTHER WARRANTIES, INCLUDING WARRANTY OF MERCHANTABILITY OR FITNESS FOR PURPOSE, WHICH EXTEND BEYOND THE PRODUCT DESCRIPTION CONFIRMED BY BUYER AND SELLER AS OF THE DATE OF FINAL AGREEMENT.**

This warranty is void if the input to the product exceeds the rated input as indicated on the product serial plate by more than 5% on gas-fired and oil-fired units, or if the product in the judgment of SELLER has been installed in a corrosive atmosphere, or subjected to corrosive fluids or gases, been subjected to misuse, negligence, accident, excessive thermal shock, excessive humidity, physical damage, impact, abrasion, unauthorized alterations, or operation contrary to SELLER'S printed instructions, or if the serial number has been altered, defaced or removed.

Heat Exchangers

For Seller's non-separated combustion Gas-Fired Unit Heaters BUYER'S REMEDY FOR BREACH OF WARRANTY, EXCLUSIVE OF ALL OTHER REMEDIES PROVIDED BY LAW, IS LIMITED TO REPAIR OR REPLACEMENT AT THE FACTORY OF SELLER, ANY HEAT EXCHANGER WHICH SHALL, WITHIN TEN YEARS FROM DATE OF FIRST BENEFICIAL USE BY BUYER OR ANY OTHER USER, WITHIN TEN YEARS FROM DATE OF RESALE BY BUYER OR ANY OTHER USER, WITHIN TEN YEARS FROM DATE OF RESALE BY BUYER IN ANY UNCHANGED CONDITION, OR WITHIN ONE HUNDRED TWENTY-SIX MONTHS FROM DATE OF SHIPMENT FROM SELLER, WHICHEVER OCCURS FIRST, BE RETURNED TO SELLER WITH TRANSPORTATION CHARGES PREPAID AND WHICH THE EXAMINATION OF SELLER SHALL DISCLOSE TO HAVE BEEN DEFECTIVE; EXCEPT THAT WHEN THE PRODUCT IS TO BE USED BY BUYER AS A COMPONENT PART OF EQUIPMENT MANUFACTURED BY BUYER, BUYER'S REMEDY FOR BREACH, AS LIMITED HEREIN, SHALL BE LIMITED TO ONE YEAR FROM DATE OF SHIPMENT FROM SELLER. FOR GAS-FIRED PRODUCTS INSTALLED IN HIGH HUMIDITY APPLICATIONS AND UTILIZING STAINLESS STEEL HEAT EXCHANGERS, BUYER'S REMEDY FOR BREACH, AS LIMITED HEREIN, SHALL BE LIMITED TO TEN YEARS FROM DATE OF SHIPMENT FROM SELLER.

For Seller's Low Intensity Gas-Fired Infrared Heaters BUYER'S REMEDY FOR BREACH OF WARRANTY, EXCLUSIVE OF ALL OTHER REMEDIES PROVIDED BY LAW, IS LIMITED TO REPAIR OR REPLACEMENT AT THE FACTORY OF SELLER, ANY HEAT EXCHANGER WHICH SHALL, WITHIN FIVE YEARS FROM DATE OF FIRST BENEFICIAL USE BY BUYER OR ANY OTHER USER, WITHIN FIVE YEARS FROM DATE OF RESALE BY BUYER OR ANY OTHER USER, WITHIN FIVE YEARS FROM DATE OF RESALE BY BUYER IN ANY UNCHANGED CONDITION, OR WITHIN 66 MONTHS FROM DATE OF SHIPMENT FROM SELLER, WHICHEVER OCCURS FIRST, BE RETURNED TO SELLER WITH TRANSPORTATION CHARGES PREPAID AND WHICH THE EXAMINATION OF SELLER SHALL DISCLOSE TO HAVE BEEN DEFECTIVE; EXCEPT THAT WHEN THE PRODUCT IS TO BE USED BY BUYER AS A COMPONENT PART OF EQUIPMENT MANUFACTURED BY BUYER, BUYER'S REMEDY FOR BREACH, AS LIMITED HEREIN, SHALL BE LIMITED TO ONE YEAR FROM DATE OF SHIPMENT FROM SELLER.

Heat Exchanger (Condensers) for all Seller's products except non-separated combustion Gas-Fired Unit Heaters and Infrared Heaters, all Burners except Infrared Heaters, and Sheet Metal for all Seller's products BUYER'S REMEDY FOR BREACH OF WARRANTY, EXCLUSIVE OF ALL OTHER REMEDIES PROVIDED BY LAW, IS LIMITED TO REPAIR OR REPLACEMENT AT THE FACTORY OF SELLER, ANY HEAT EXCHANGER (CONDENSER) OR BURNER WHICH SHALL, WITHIN ONE YEAR FROM DATE OF FIRST BENEFICIAL USE BY BUYER OR ANY OTHER USER, WITHIN ONE YEAR FROM DATE OF RESALE BY BUYER IN ANY

UNCHANGED CONDITION, OR WITHIN EIGHTEEN MONTHS FROM DATE OF SHIPMENT FROM SELLER, WHICHEVER OCCURS FIRST, BE RETURNED TO SELLER WITH TRANSPORTATION CHARGES PREPAID AND WHICH THE EXAMINATION OF SELLER SHALL DISCLOSE TO HAVE BEEN DEFECTIVE; EXCEPT THAT WHEN THE PRODUCT IS TO BE USED BY BUYER AS A COMPONENT PART OF EQUIPMENT MANUFACTURED BY BUYER, BUYER'S REMEDY FOR BREACH, AS LIMITED HEREIN, SHALL BE LIMITED TO ONE YEAR FROM DATE OF SHIPMENT FROM SELLER.

Burners

For Seller's Low Intensity Gas-Fired Infrared Heaters BUYER'S REMEDY FOR BREACH OF WARRANTY, EXCLUSIVE OF ALL OTHER REMEDIES PROVIDED BY LAW, IS LIMITED TO REPAIR OR REPLACEMENT AT THE FACTORY OF SELLER, ANY BURNER WHICH SHALL, WITHIN TWO YEARS FROM DATE OF FIRST BENEFICIAL USE BY BUYER OR ANY OTHER USER, WITHIN TWO YEARS FROM DATE OF RESALE BY BUYER IN ANY UNCHANGED CONDITION, OR WITHIN 30 MONTHS FROM DATE OF SHIPMENT FROM SELLER, WHICHEVER OCCURS FIRST, BE RETURNED TO SELLER WITH TRANSPORTATION CHARGES PREPAID AND WHICH THE EXAMINATION OF SELLER SHALL DISCLOSE TO HAVE BEEN DEFECTIVE; EXCEPT THAT WHEN THE PRODUCT IS TO BE USED BY BUYER AS A COMPONENT PART OF EQUIPMENT MANUFACTURED BY BUYER, BUYER'S REMEDY FOR BREACH, AS LIMITED HEREIN, SHALL BE LIMITED TO ONE YEAR FROM DATE OF SHIPMENT FROM SELLER.

For Seller's High Intensity Gas-Fired Infrared Heaters BUYER'S REMEDY FOR BREACH OF WARRANTY, EXCLUSIVE OF ALL OTHER REMEDIES PROVIDED BY LAW, IS LIMITED TO REPAIR OR REPLACEMENT AT THE FACTORY OF SELLER, ANY BURNER WHICH SHALL, WITHIN TEN YEARS FROM DATE OF FIRST BENEFICIAL USE BY BUYER OR ANY OTHER USER, WITHIN TEN YEARS FROM DATE OF RESALE BY BUYER IN ANY UNCHANGED CONDITION, OR WITHIN 126 MONTHS FROM DATE OF SHIPMENT FROM SELLER, WHICHEVER OCCURS FIRST, BE RETURNED TO SELLER WITH TRANSPORTATION CHARGES PREPAID AND WHICH THE EXAMINATION OF SELLER SHALL DISCLOSE TO HAVE BEEN DEFECTIVE; EXCEPT THAT WHEN THE PRODUCT IS TO BE USED BY BUYER AS A COMPONENT PART OF EQUIPMENT MANUFACTURED BY BUYER, BUYER'S REMEDY FOR BREACH, AS LIMITED HEREIN, SHALL BE LIMITED TO ONE YEAR FROM DATE OF SHIPMENT FROM SELLER.

All Other Components Excluding Heat Exchanger (Condenser), Burner, and Sheet Metal

For all Seller's products except Direct-Fired Heaters and High Intensity Gas-Fired Infrared Heaters BUYER'S REMEDY FOR BREACH OF WARRANTY, EXCLUSIVE OF ALL OTHER REMEDIES PROVIDED BY LAW, IS LIMITED TO REPAIR OR REPLACEMENT AT THE FACTORY OF SELLER, ANY PART OR PARTS WHICH SHALL, WITHIN TWO YEARS FROM DATE OF FIRST BENEFICIAL USE BY BUYER OR ANY OTHER USER, WITHIN TWO YEARS FROM DATE OF RESALE BY BUYER IN ANY UNCHANGED CONDITION, OR WITHIN THIRTY MONTHS FROM DATE OF SHIPMENT FROM SELLER, WHICHEVER OCCURS FIRST, BE RETURNED TO SELLER WITH TRANSPORTATION CHARGES PREPAID AND WHICH THE EXAMINATION OF SELLER SHALL DISCLOSE TO HAVE BEEN DEFECTIVE; EXCEPT THAT WHEN THE PRODUCT IS TO BE USED BY BUYER AS A COMPONENT PART OF EQUIPMENT MANUFACTURED BY BUYER, BUYER'S REMEDY FOR BREACH, AS LIMITED HEREIN, SHALL BE LIMITED TO ONE YEAR FROM DATE OF SHIPMENT FROM SELLER.

For Seller's Direct-Fired Heaters and High Intensity Gas-Fired Infrared Heaters BUYER'S REMEDY FOR BREACH OF WARRANTY EXCLUSIVE OF ALL OTHER REMEDIES PROVIDED BY LAW IS LIMITED TO REPAIR OR REPLACEMENT AT THE SELLER'S OPTION ANY PART OR PARTS WHICH SHALL WITHIN A PERIOD OF ONE YEAR FROM DATE OF FIRST BENEFICIAL USE BY BUYER OR ANY OTHER USER, WITHIN ONE YEAR FROM DATE OF RESALE BY BUYER IN ANY UNCHANGED CONDITION, OR WITHIN 18 MONTHS FROM DATE OF SHIPMENT FROM SELLER, WHICHEVER OCCURS FIRST, BE RETURNED TO SELLER WITH TRANSPORTATION CHARGES PREPAID AND WHICH THE EXAMINATION OF THE SELLER SHALL DISCLOSE TO HAVE BEEN DEFECTIVE.

BUYER AGREES THAT IN NO EVENT WILL SELLER BE LIABLE FOR COSTS OF PROCESSING, LOST PROFITS, INJURY TO GOODWILL, OR ANY OTHER CONSEQUENTIAL OR INCIDENTAL DAMAGES OF ANY KIND RESULTING FROM THE ORDER OR USE OF ITS PRODUCT, WHETHER ARISING FROM BREACH OF WARRANTY, NONCONFORMITY TO ORDERED SPECIFICATIONS, DELAY IN DELIVERY, OR ANY LOSS SUSTAINED BY THE BUYER.

As Modine Manufacturing Company has a continuous product improvement program, it reserves the right to change design and specifications without notice.



6-579

Commercial HVAC&R Division

Modine Manufacturing Company
1221 Magnolia Avenue
Buena Vista, Virginia 24416
Phone: 1.800.828.4328 (HEAT)
Fax: 540.261.1903 (Service & Parts)
www.modine.com