

TECHNICAL SPECIFICATIONS

CTF2-6060

MODEL NUMBER 141097

DIMENSIONS: 59" x 59" x 21 1/2" Gelcoat

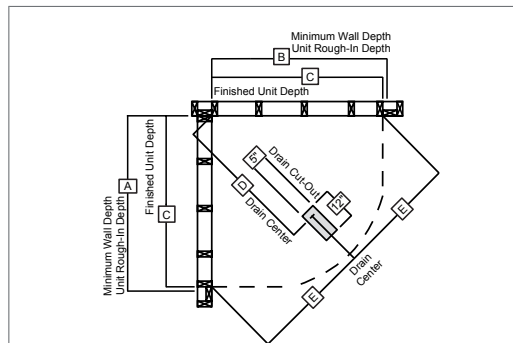

Model	A	B	C	D	E
141097	60 1/2"	60 1/2"	59"	45 1/4"	41 1/2"

STANDARD FEATURES

- Spacious bathingwell
- Drop-in installation
- 2 backrests with lumbar support
- Integrated tiling flange
- Armrests
- Deck for faucet
- Textured floor
- Center drain
- 19 3/4" deep sump
- Bottom bathing well: 57" L x 40" W

UNIQUE FEATURES

- Tiling Flange

OPTIONS

- In-line heater (factory-installed)
- Pump position opposite standard position
- Ozonator for Bodywrap whirlpool system
- Trim Kit for Bodywrap Whirlpool System

SYSTEMS

- Homestead Bodywrap

DOOR SELECTION

Combine with AKER's complete shower door offering visit www.akerbymax.com

CERTIFICATIONS

AKER products adhere to one or more of the following certifications:



Project :

Contractor :

AKER Representative : Tel :

Date :

TECHNICAL SPECIFICATIONS

CTF2-6060

MODEL NUMBER 141097

TECHNICAL DRAWINGS

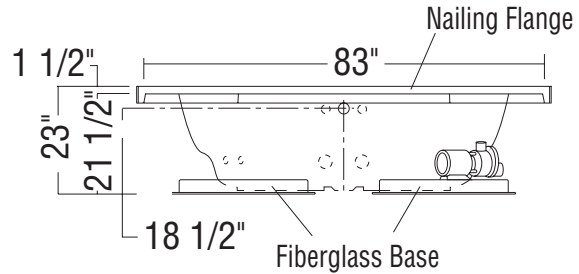
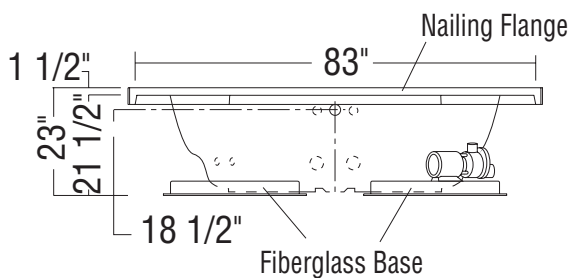
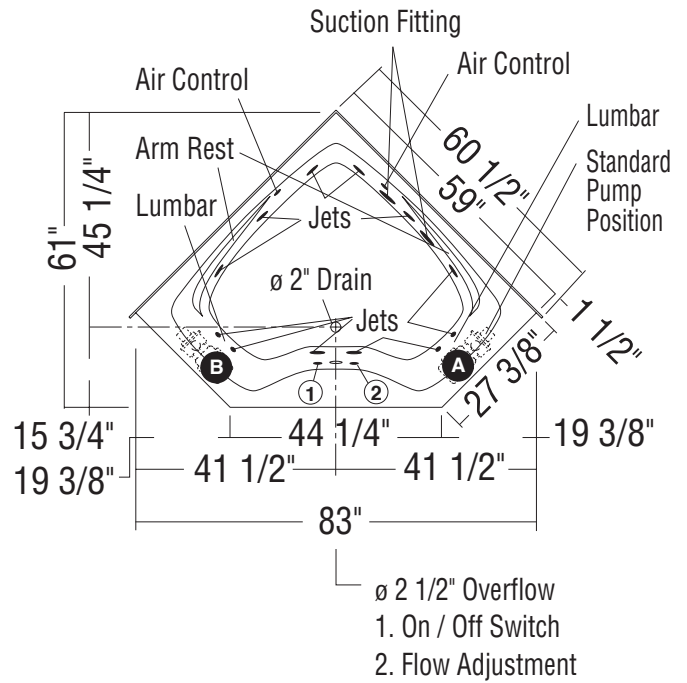
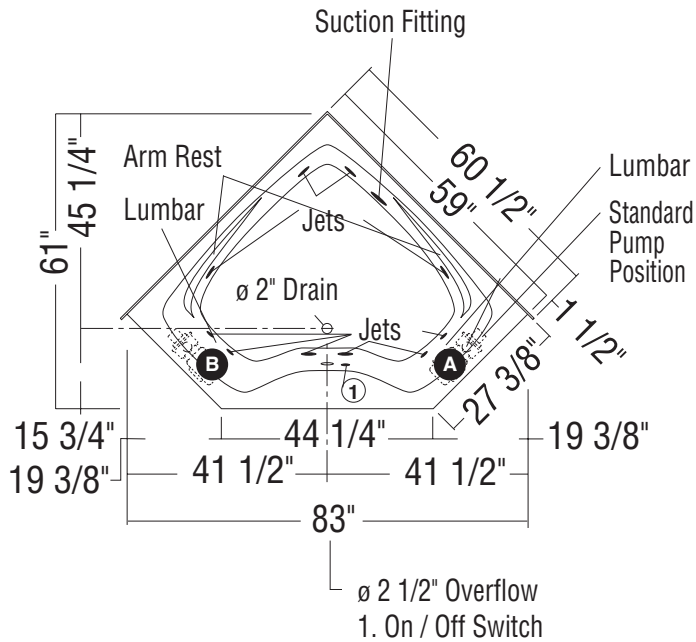

10-jet Homestead Collection CTF2-6060
HMS (illustrated)

12-jet Bodywrap System CTF2-6060
BWS (illustrated)