

Technical
guide

How to install D400 manhole covers





How to install D400 manhole covers

1 Check the diameter of the manhole opening or groove that the frame is to be fitted on.

If necessary, insert a formwork around and/or inside the manhole on which the cover is to be fitted.

Make sure that the frame does not lay on the formwork when in its final position.



How to install D400 manhole covers

2 Check the condition of the manhole opening or groove, removing any debris, loose particles or dirt (oil, grease, etc.).

Remove any dust from the support.

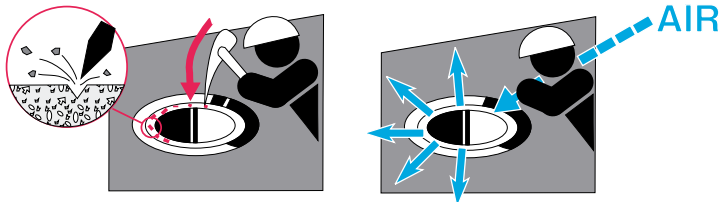

3 Do not use any (metal or wooden...) brackets, or any threaded spindles when adjusting the height of the frame.

 The cover must only be in contact with the sealing product!

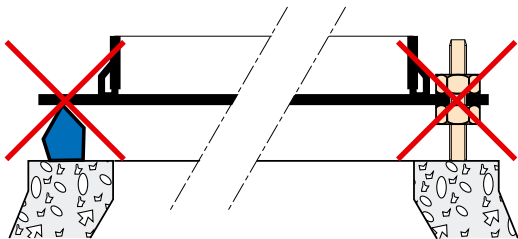

How to install D400 manhole covers

- 4** Lay a coat of sealing product around the top of the manhole. The minimum recommended thickness for the coat under the frame, once installed and levelled, is:
- 4 cm in the case of quick setting "micro-concrete" type sealing products,
 - 8 cm in the case of a 350 CPA concrete sealing.

It is essential to follow very carefully the instructions of the product used.

For example a frame of height 100 mm:

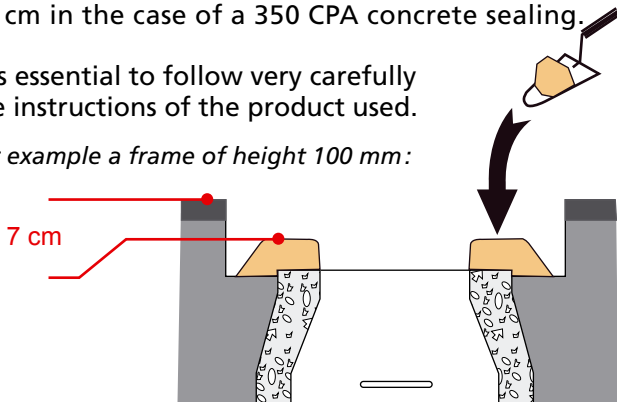

How to install D400 manhole covers

- 5 Lay the frame directly on the sealing product.

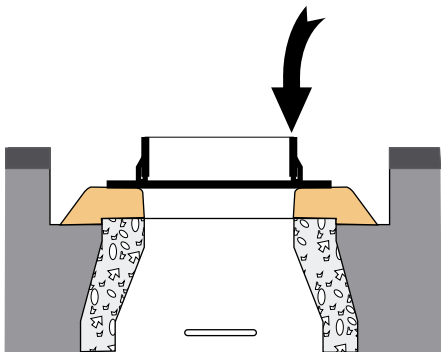

How to install D400 manhole covers

6 Adjust the frame to the same level as the wearing course.

This adjustment should be carried out by exerting downward pressure on the frame to ensure that the sealing product spreads evenly under the surface.

If the frame is situated below the surface level, then you must go back to point 4 and repeat the operation **4**.

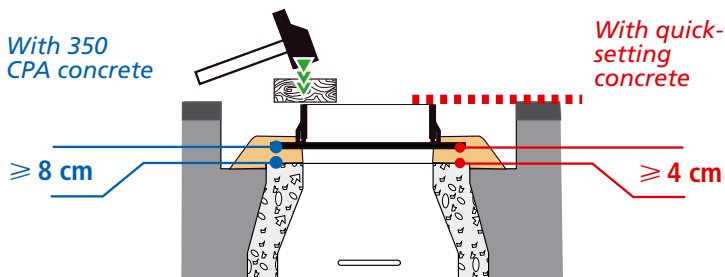

How to install D400 manhole covers

7 Check that the frame openings have been completely filled.



How to install D400 manhole covers

- 8** Fill with sealing product.
At this stage you may opt to vibrate the concrete using vibrating needles, providing that you ensure that this will not alter the level of the frame.

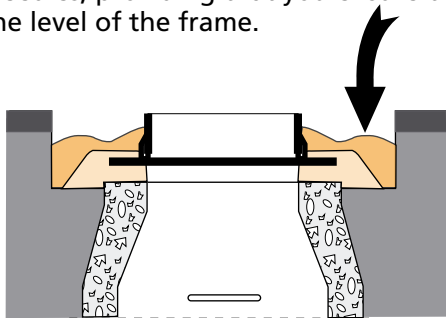

- 9** Use a float or trowel to level off the product, leaving 3 to 5 cm for the later laying of the asphalt course.

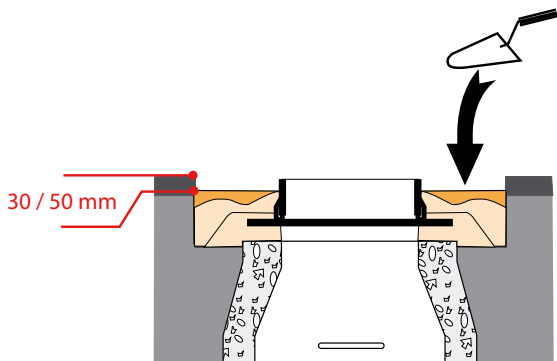

How to install D400 manhole covers

PLEASE NOTE

Following installation, it is essential to check that the sealing product is not touching the lower section of the ring and prior to use, clean the manhole cover and the surrounding area thoroughly.

Particular care must be taken with the operating parts, namely the hinges, the elastomer ring or others, the bases, the spaces for the openings, etc.

In the case of PAMREX covers, leave a clearance space under the hinge box.

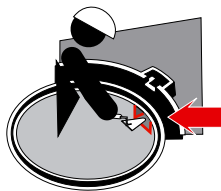
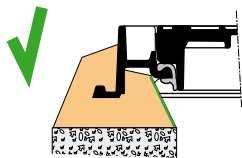
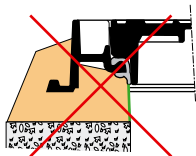

USEFUL TIP

In order to ensure that the sealing will last, especially under conditions of frost and thawing, we advise eliminating the water inlets on the sealing/roadway and sealing/frame interfaces by using either a liquid emulsion or a flexible joint.

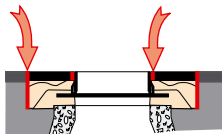

ROADWAY REPAIRS:

In the event of roadway repair work, the following precautions must be taken:

- Remove the frame seal with care to prevent any possible damage.
- Check that the mechanism has not suffered any wear and tear (e.g. caused by the cutting of the asphalt course).
- Remove any faulty parts or those you suspect may be faulty.
- Take care when resealing the frame, applying the same recommendations given for the initial sealing process.
- Check the state of the ring and change it if necessary: *the ring is a maintenance element. Regular replacement will allow performance levels to be maintained over time.*

You must also carry out the same checks (see p. 8) as in the case of an initial sealing process.

RECOMMENCEMENT OF USE IN TRAFFIC:

The seal must offer sufficient performance guarantees in order to withstand the general mechanical stress generated by traffic before the manhole cover can become operational once more..

Please refer to the sealing product specifications in order to determine the length of time before the manhole cover can be used under traffic conditions.

SAINT-GOBAIN PAM worldwide

PAM ALGERIA

Tel : + 213 (0) 25 36 00 60

PAM ANTILLES

Tel : + 33 590 26 71 46

PAM ARGENTINA

Tel : + 54 11 4298 9600

PAM AUSTRALIA

Tel : + 61 (0) 3 9358 6122

PAM AUSTRIA

Tel : + 43 512 341 717-0

PAM BELGIUM

Tel : + 32 11 88 01 20

PAM BRAZIL

Tel : + 55 21 2128 1677

PAM CHILE

Tel : + 562 444 13 00

PAM CHINA

Tel : + 86 21 6361 2165

PAM COLOMBIA

Tel : + 57 (1) 841 5832

PAM CZECH REPUBLIC

Tel : + 420 311 712 611

PAM FINLAND

Tel : + 358 207 424 600

PAM FRANCE

Tel : + 33 3 83 80 73 50

PAM GERMANY

Tel : + 49 681 87 010

PAM GREECE

Tel : + 30 210 614 7500

PAM HONG KONG

Tel : + 852 27 35 78 26

PAM INDIA

Tel : + 91 22 402 12 121

PAM ITALY

Tel : + 39 02 42 431

PAM JORDAN

Tel : + 962 6 551 4438

PAM MEXICO

Tel : + 52 55 5279 1657

PAM NETHERLANDS

Tel : + 31 36 53 333 44

PAM NORWAY

Tel : + 47 23 17 58 60

PAM PERU

Tel : + 511 252 40 34/35

PAM POLAND

Tel : + 48 22 751 41 72

PAM PORTUGAL

Tel : + 351 218 925 000

PAM REUNION ISLAND

Tel : + 33 262 55 15 34

PAM ROMANIA

Tel : + 40 21 207 57 37

PAM SLOVAKIA

Tel : + 421 265 43 69 61

PAM SOUTH AFRICA

Tel : + 27 12 657 2800

PAM SPAIN

Tel : + 34 91 397 20 00

PAM UNITED ARAB EMIRATES

Tel : + 971 2 448 20 10

PAM UNITED KINGDOM

Tel : + 44 115 930 5000

PAM VIETNAM

Tel : + 84 8 3930 7273

www.pamline.com

SAINT-GOBAIN PAM

Head Office

91, avenue de la Libération
54076 NANCY CEDEX
FRANCE

Marketing Department

21, avenue Camille Cavallier
54705 PONT-A-MOUSSON CEDEX
FRANCE
Tél. : +33(0)3 83 80 73 50