

- SHIPPED DETACHED:
- 1- DUMMY END SHIELD
  - 8- 8-32 NUTS
  - 2- HUB RINGS
  - 1- CAPACITOR
  - 1- CAPACITOR CLAMP
  - 1- CAPACITOR CAP
  - 2- 10-32 SCREWS

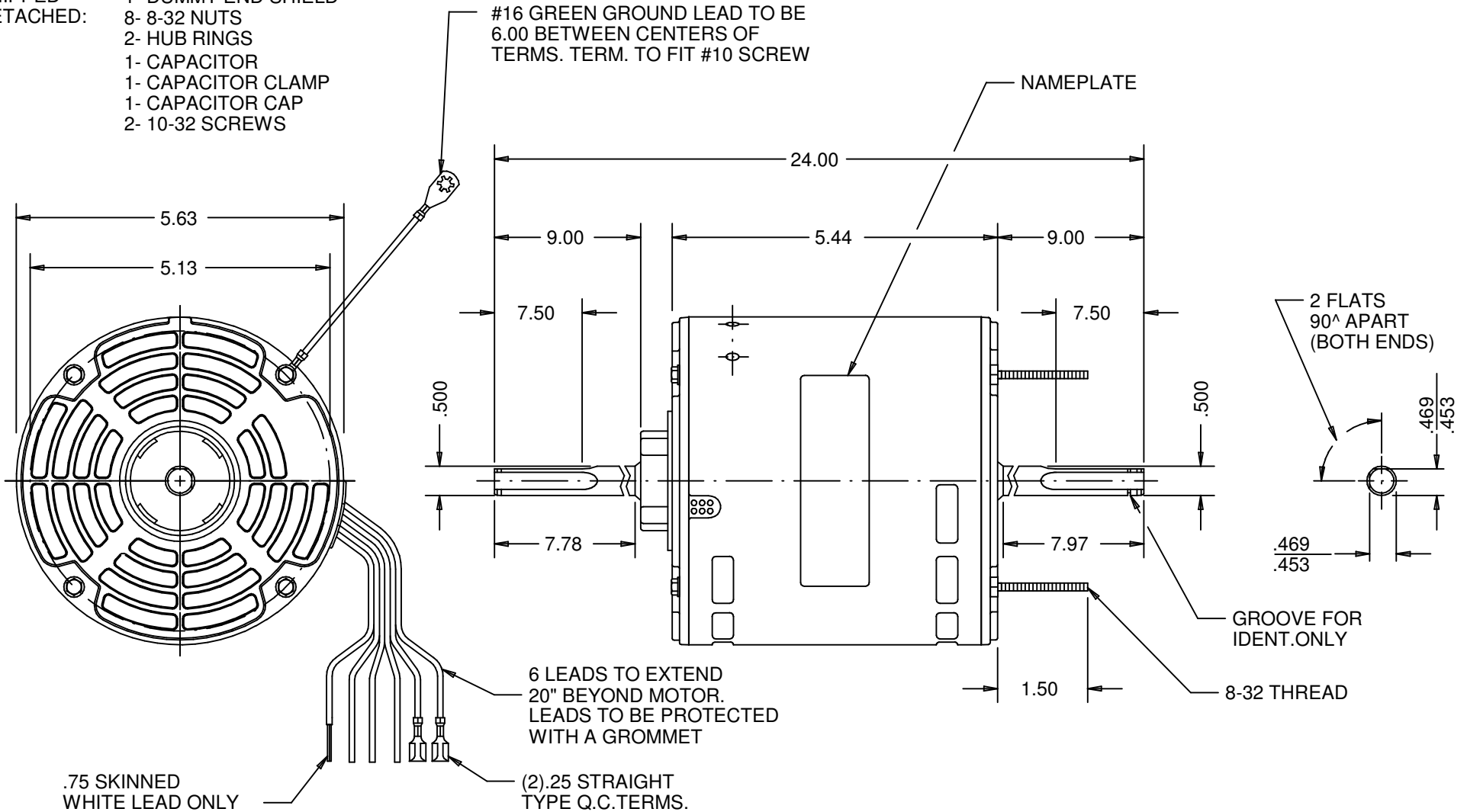

INCLUDES 5.0 MFD 370-VAC CAPACITOR

NIDEC MOTOR CORPORATION 22-Oct-12

MODEL	REF	CUSTOMER	HP	VOLTS	AMPS	HZ	RPM	PROTECTOR	BEARING
KA55HXWP-9031	-	STANDARD	1/2	230	4.5	60	1075/3SPD	AUTOMATIC	SLEEVE
								ROTATION	CUSTOMER PN
								CCW LEAD END REV	1824

SHEET NUMBER	REV	REVISION RECORD FOR: C6406-00	
1 OF 1	D	UPDATED "ENGINEER APPROVED" TO B. GAITAN	
REVISION DATE			
22-OCT-12			

INFORMATION DISCLOSED ON THIS DOCUMENT IS CONSIDERED PROPRIETARY AND SHALL NOT BE REPRODUCED OR DISCLOSED WITHOUT WRITTEN CONSENT OF NIDEC MOTOR CORPORATION

ALL DIMENSIONS ARE FOR REFERENCE ONLY UNLESS TOLERANCE IS GIVEN

**NIDEC MOTOR CORPORATION**

TITLE: ASSEMBLED VIEW

CODE: V01

ITEM NO.: 252368

SIZE: A

ISSUED BY	REVIEWED BY	ENGINEER APPROVED	REV.
B. ANDRADE	M. LARGENT	B. GAITAN	D