

# INSTALLATION INSTRUCTIONS

Read installation instructions first before installing. Check parts to ensure that no damage has occurred during transit and that no parts are missing. Also check the diameter of the pipe and the range marked on the coupling to ensure you have the proper size.

## Style FCA501 Flanged Coupling Adapter

**Step 1** • Check the flanged coupling parts and confirm that no damage has occurred during transit and that no parts are missing.

**Step 2** • Clean pipe end for a distance of 2" greater than length of the coupling.

**Step 3** • Check area where gaskets will seat to make sure there are no dents, projections, gouges, etc., that will interfere with the gasket seal. Welds must be ground flush.

**Step 4** • Place end ring on pipe end.

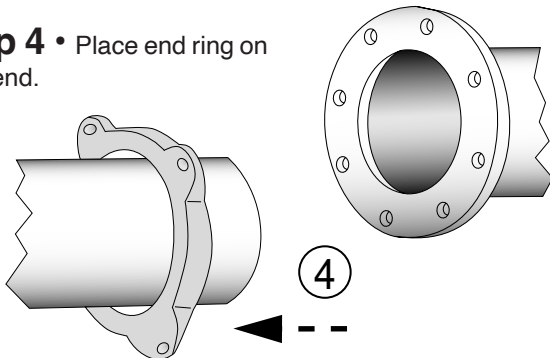

**Step 5** • Lubricate gaskets with a suitable gasket lubricant. Place gasket next to end ring with beveled edge toward the pipe end.

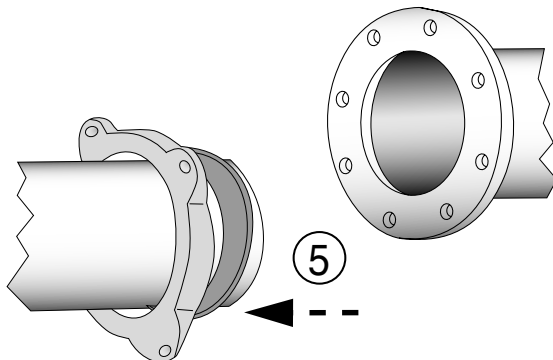

**Note: Flanged Couplings without anchor pins do not provide protection against axial force. Suitable anchorage should be provided.**

**Step 6A • Flanged Couplings with Anchor Pins:**

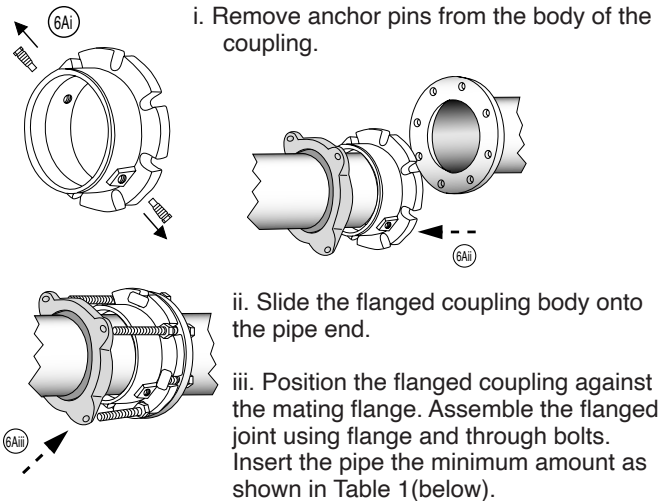

**Table 1**

Pipe Size	MIN. PIPE INSERTION	
	Without Anchor Pins	With Anchor Pins
3" to 8"	2"	3"
10" to 12"	3"	4"
16"	3"	NA

iv. Thread a short pipe nipple into the threaded anchor pin hole. Using the largest drill bit that will fit into the pipe nipple, drill a center mark on the pipe. Do not drill through.

v. Drill a  $\frac{5}{16}$ " hole through the center mark made in step iv.

vi. Remove the pipe nipple, and complete the hole through the pipe (see Table 2 for the hole size). Use care so as not to damage the threads.

**Table 2**

Pin Size	Thread Size	Hole Size for Pipe
$\frac{1}{2}$ "	$\frac{3}{8}$ " NPT	$\frac{17}{32}$ "
$\frac{5}{8}$ "	$\frac{1}{2}$ " NPT	$\frac{21}{32}$ "
$\frac{7}{8}$ "	$\frac{3}{4}$ " NPT	$\frac{29}{32}$ "

vii. Install the anchor pins. Apply a suitable thread sealant and tighten to prevent leakage.

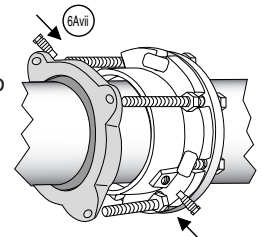

**Installation Instructions continued on back**

## Style FCA501 (continued from front)

### Step 6B • Flanged Couplings without Anchor Pins:

Slide the flanged coupling assembly onto the pipe. Position the pipe and flanged coupling against the mating flange. Assemble the flange joint using flange bolts.

**Step 7 •** The pipe should be centered such that the space between the OD of the pipe and the ID of the FCA body is even all around the pipe. Slide flanged coupling gasket into position with the beveled edge engaging the beveled end of the flanged coupling body.

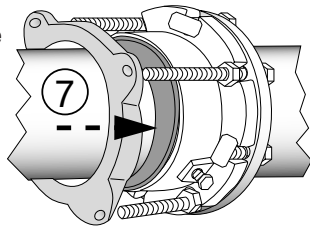

**Step 8 •** Slide end ring into position (engaging the through bolts) against the gasket.

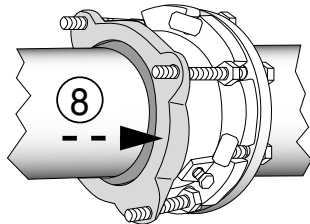

**Step 9 •** Bolt tightening should be done evenly, alternating to diametrically opposite positions at approximately 20 ft-lbs. increments to bring bolts to recommended tightness.

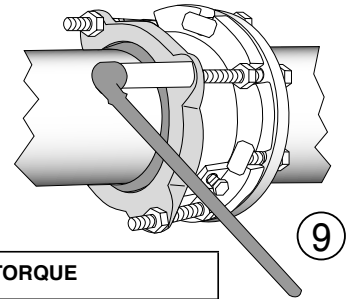

RECOMMENDED TORQUE		
FCA501 SIZE	END RING BOLTS	FLANGE BOLTS
3"	60 - 70 FT-LBS	75 - 85 FT-LBS
4"	60 - 70 FT-LBS	75 - 85 FT-LBS
6"	75 - 85 FT-LBS	90 - 100 FT-LBS
8"	75 - 85 FT-LBS	90 - 100 FT-LBS
10"	60 - 70 FT-LBS	150 - 160 FT-LBS
12"	85 - 95 FT-LBS	150 - 160 FT-LBS
16"	60 - 70 FT-LBS	235 - 245 FT-LBS



**Wait 10 minutes and retighten to account for settling of the gasket.**

**Step 10 •** Confirm proper installation by pressurizing the line and checking for leaks.

## PRECAUTIONS

1. Check diameter of pipe to make sure you are using the correct size coupling; also check gasket to make sure it is the size you think it is.
2. Clean pipe to remove dirt and corrosion from pipe surface. Lubrication and additional cleaning should be provided by brushing both the gasket and plain pipe end with soapy water or approved pipe lubricant per ANSI/AWWA C111/A21.11.
3. Make sure no foreign materials lodge between gasket and pipe.
4. Avoid loose fitting wrenches, or wrenches too short to achieve proper torque.
5. Keep threads free of foreign material to allow proper tightening.
6. Take extra care to follow proper bolt tightening procedures and torque recommendations. Bolts are often not tightened enough when a torque wrench is not used.
7. Pressure test for leaks before backfilling.
8. Backfill and compact carefully around pipe and fittings.
9. When reinstalling parts with stainless steel hardware, there may be a loss in pressure holding ability due to worn or damaged threads during the original installation.

## COMMON INSTALLATION PROBLEMS

1. Bolts are not tightened to the proper torque.
2. Rocks or debris between pipe and gasket.
3. Dirt on threads of bolts or nuts.
4. Not enough pipe insertion when installing anchor pins.