

VXT-100

Submittal Data Information

Programmable Steam Boiler Water Feeder



Supersedes: NEW

Effective: January 1, 2007

JOB _____ ENGINEER _____ CONTRACTOR _____

Item Number	Model Number	NOTES

FEATURES

- **Universal Compatibility**-The VXT can be used with virtually any probe or float type low water cut-off.
- **Digital Feed Counter**-Displays the amount of water added to the boiler - essential in detecting boiler destroying water loss problems.
- **Programmable Feed Delay**-Helps prevent flooded boilers by allowing time for condensate to return to boiler before initiating a feed cycle.
- **Programmable Feed Amount**-Two ways to feed; gallon amount settings can feed above the probe to a working water line. LWCO setting ends feed when LWCO reenergizes the burner.
- **Underfeed Protection**-If one feed cycle is not enough to restore boiler operation, the VXT will delay and feed one additional time.
- **Lock-Out Flood Protection**-The VXT will lock out to prevent system flooding and costly water damage if burner operation does not resume after two consecutive feed cycles.
- **Manual Feed Button**-Manual feed amounts are recorded and added to the gallon total displayed on counter.

Standard Application

VXT Steam Boiler Water Feeders are primarily used on residential and light commercial steam heating boilers up to 500,000 Net BTUH. They are not recommended for commercial steam process work.

Operation

The VXT feeder should be wired to and receive its signal from a float or probe type low water cut-off. When the VXT receives a signal from the LWCO, it initiates an adjustable delay before feed to allow condensate from the system to return to the boiler and near boiler piping. Upon completion of the delay, if the LWCO feed signal is still present, the feeder begins its feed cycle. If the feed signal is still present after the completion of the feed cycle, the control will revert back to its delay mode. After the second delay expires the control will begin another feed cycle. If the signal is still present after the second feed cycle, the control will lock-out until the feed signal from the LWCO has been removed. Once in lock-out, the feeder can be forced to feed an additional two cycles each time power is removed then reapplied.

- **Digital Feed Counter** -The counter displays the amount of water fed into the boiler in gallons. The display will blink if the counter has exceeded 999. The display can be reset by pushing the "reset" button for 2 seconds.
- **Programmable Feed Delay**- Delay settings available: 30 seconds, 2 minutes (factory setting), 4 minutes, 6 minutes, 8 minutes, 10 minutes.
- **Programmable Feed Amount**- Feed amounts available: LWCO (factory setting), 1 gallon, 2 gallons, 3 gallons, 4 gallons, 5 gallons.

Dimensions

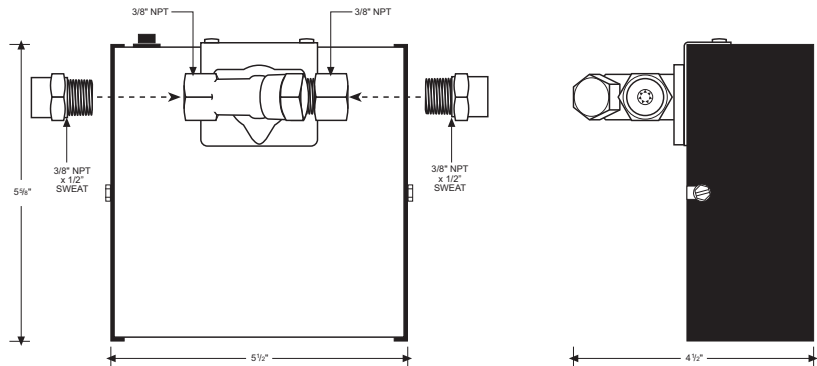

VXT SPECIFICATIONS

- Maximum Fluid Temp.....150° F
- Flow Rate.....1GPM
- Maximum Feed.....10 Gallons (2 cycles)
- Max. Steam Boiler Pressure.....15 psi
- Max. Incoming Water Pressure...150 psi
- Power Consumption (solenoid open)15VA @ 24VAC or 10VA @ 120VAC 50/60HZ
- Pipe Connections.....3/8" w / (2) 3/8"X1/2" Sweat Adaptors
- Input Voltage.....24VAC/60HZ or 120VAC/60HZ
- Control Housing.....NEMA1-Indoor Use



83 Water Street, New Haven, CT 06511
Phone: (203) 776-0473 • Fax: (203) 773-1019
email address: info@hydrolevel.com
Visit our website at:

www.hydrolevel.com