

32
1452
1206

No. 32 Transporter

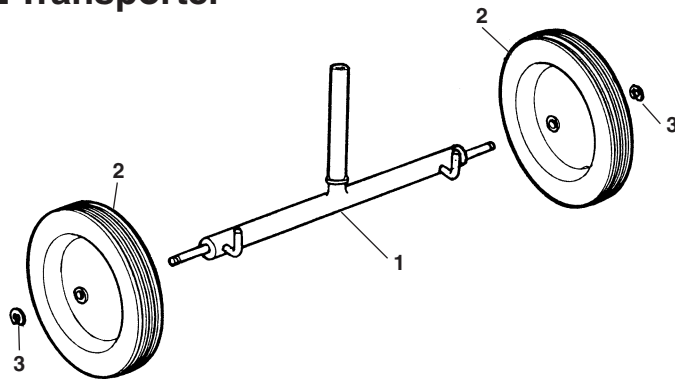

NOTE: Order parts by Catalog Number only.
DO NOT order by Reference Number.

Ref. No.	Catalog No.	Description
—	42575	No. 32 Transporter
1	42590	Axle & Support Tube Assembly
2	42585	Wheel (2)
3	42580	Retaining Ring (2)

No. 1452 Clip-On Tool Tray

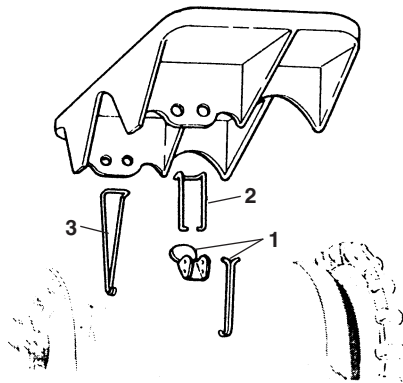

Ref. No.	Catalog No.	Description
—	22638	No. 1452 Tool Tray
1	45535	Hook & Lever Assembly
2	45540	Top Hook
3	45545	Side Hook
4	78367	Warning Decal (Not Shown)

No. 1206 Stand

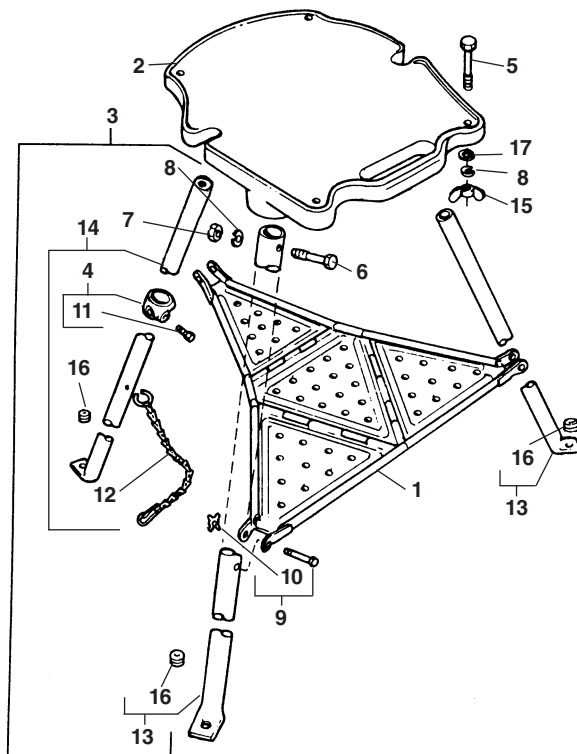

Ref. No.	Catalog No.	Description
—	42360	1206 Stand Complete
1	43475	B-547 Tool Tray
2	42870	B-1058 Base
3	42990	B-1983-X Tray & Leg Assembly
4	41235	D-488-X Tray Support
5	46670	E-867 Bolt 3/8" - 16 x 2" (4)
6	46675	E-868 Bolt 3/8" - 16 x 2 1/2" (3)
7	44225	E-1094 Nut 3/8" - 16 (3)
8	40930	E-1095 Lock Washer 3/8" (7)
9	41265	E-1375-X Pin w/Washer (1 7/8" Long)
	89720	E-10396-X Pin w/Washer (1 5/8" Long)
10	41270	E-1377 X-Washer (6)
11	41245	E-1380 Set Screw 3/8" - 16 x 1"
12	40945	E-1444-X Chain Assembly
13	45325	E-1336-X Front Leg (2)
14	45330	E-3237-X Rear Leg
15	45385	E-3328 Wing Nut 3/8" - 16 (4)
16	40940	F-532 Grommet (3)
17	44230	E-1096 Washer 3/8" (4)