

Installer's Guide

Full Perimeter Roof Mounting Curb

Model:
BAYCURB050A

Used With:
2/4YC*,WC*,TC*,DC018-036A**

ALL phases of this installation must comply with NATIONAL, STATE, AND LOCAL CODES

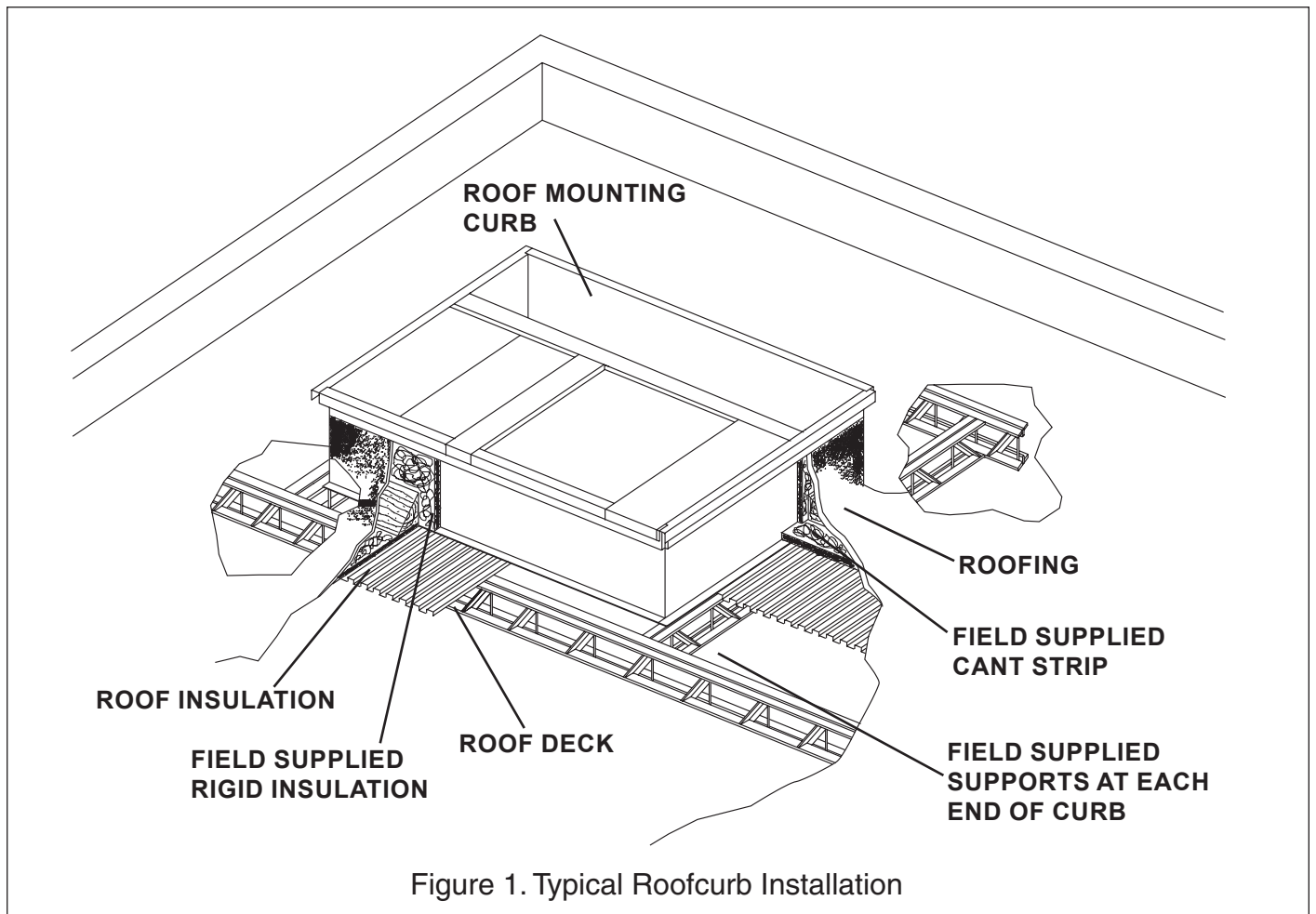

The drawings in this document are prepared by the manufacturer in order to provide detail regarding job layout only. These drawings are not intended to be used as a basis to construct, build or modify the items depicted in the drawings. The manufacturer is not responsible for the unauthorized use of these drawings and expressly disclaims any liability for damages resulting from such unauthorized use.

Installer's Guide

This booklet covers the rooftop curb listed for the 1-1/2 thru 3 ton models only SINGLE PACKAGE UNITS.

These instructions are organized for an easy step-by-step procedure.

The BAYCURB050A FULL PERIMETER ROOF MOUNTING CURB (or Frame) is to be field assembled with insulation on side and end rails. See page 1.

For instructions related to the Single Package Unit, refer to the instructions packaged with that unit.

NOTE: The roof mounting curb (frame) not only provides support for the unit, but permits easy penetration of the roof for the connecting ductwork. The roof mounting curb provides for proper flashing and sealing by the roofing contractor as approved by the National Roofing Contractors Association.

These instructions do not purport to cover all variations in systems nor to provide for every possible contingency to be met in connection with installation. Should further information be desired or should particular problems arise which are not covered sufficiently for the purchaser's purposes, the matter should be referred to the manufacturer.

Check for transportation damage after kit is uncrated. Report promptly, to the carrier, any damage found to the kit.

1. Adequate support must be provided beneath the roof

mounting curb for the entire length of the curb. The total weight of the unit, curb, and duct, plus any accessories, must be considered when selecting and placing the curb on the roof.

2. Be sure location of the roof mounting curb will allow needed service clearance around unit when the unit is in place. (As illustrated below).

3. **Roof Mounting Curb (frame) must be installed on a flat, level section of the roof (maximum of 1/4" per foot pitch). Provide a level mounting surface for the unit, even if the roof is not level. If the pitch of the roof exceeds 1/4" per foot, it will be necessary for the contractor to construct a level subbase on which to install the roof mounting curb.**

4. Do not locate the mounting curb near exhaust vents or other sources of contaminated air that could enter the unit air inlets. Guard against water run off from higher overhanging structures.

5. Field Fabricated Ductwork -- Secure all ducts to building structure. Use flexible duct connectors between curb and ducts. Ducts passing through unconditioned space must be insulated and covered with a vapor barrier.

Required Clearance for Unit Installation and Roof Penetration Hole Size Required for Full Perimeter BAYCURB050A

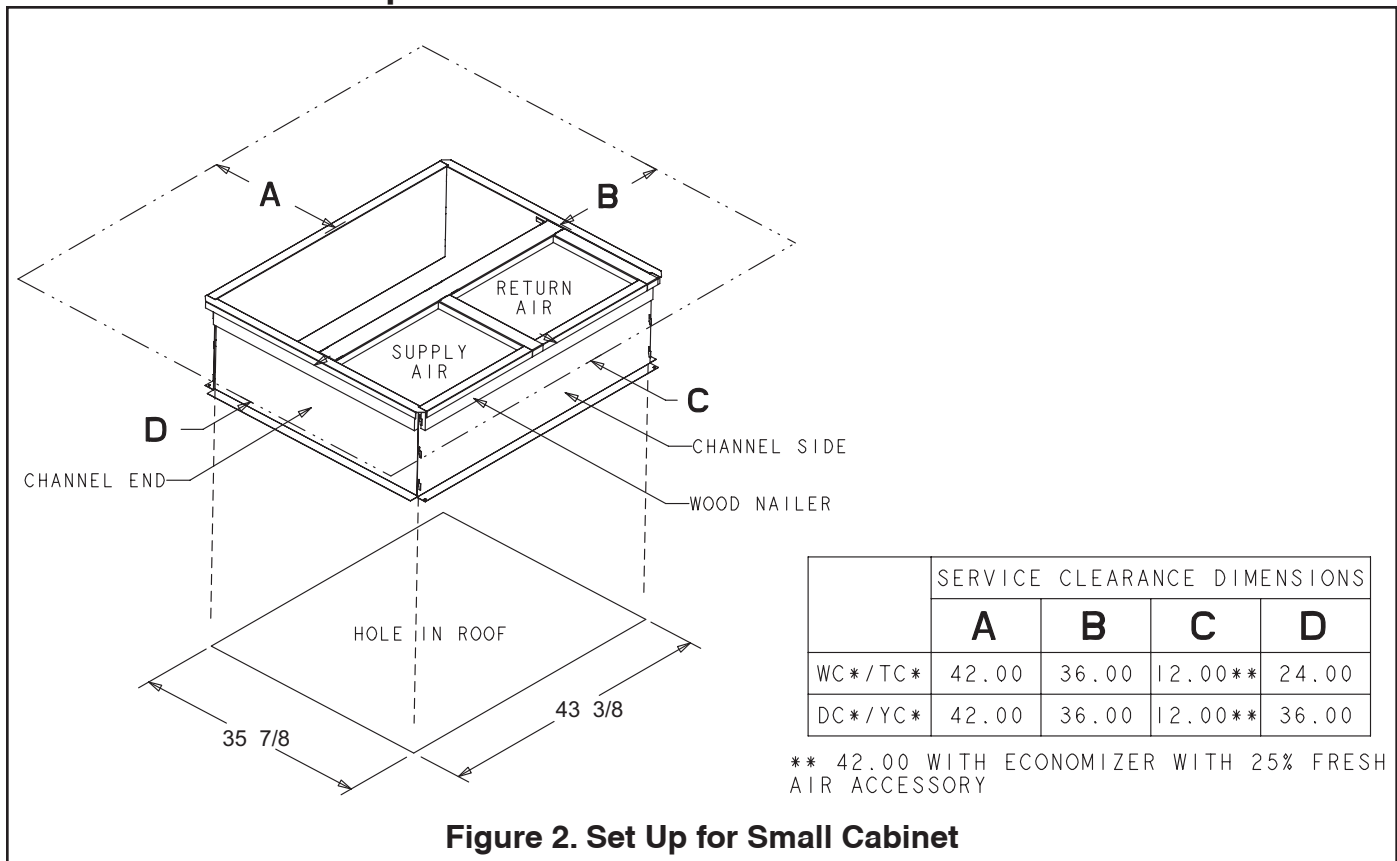

Figure 2. Set Up for Small Cabinet

Roof Mounting Curb and Supply/Return Size Required Air Opening

⚠ CAUTION

The opening must be covered temporarily to prevent anyone or anything from falling through the opening. Follow this safety precaution when working in other areas of installation, and when leaving the job site overnight or for any extended period of time.

1. All duct work must be installed in accordance with the National Fire Protection Association Standards No. 90A and 90B.
2. Remove only that portion of the roof deck to permit the installation of field fabricated air ducts.

Roof decking remaining beneath unit base pan will reduce sweating on bottom of unit base pan during high humidity conditions.

3. All components for BAYCURB050A are used to assemble roof curb.
4. See Figure 4, page 4, for components of curb.

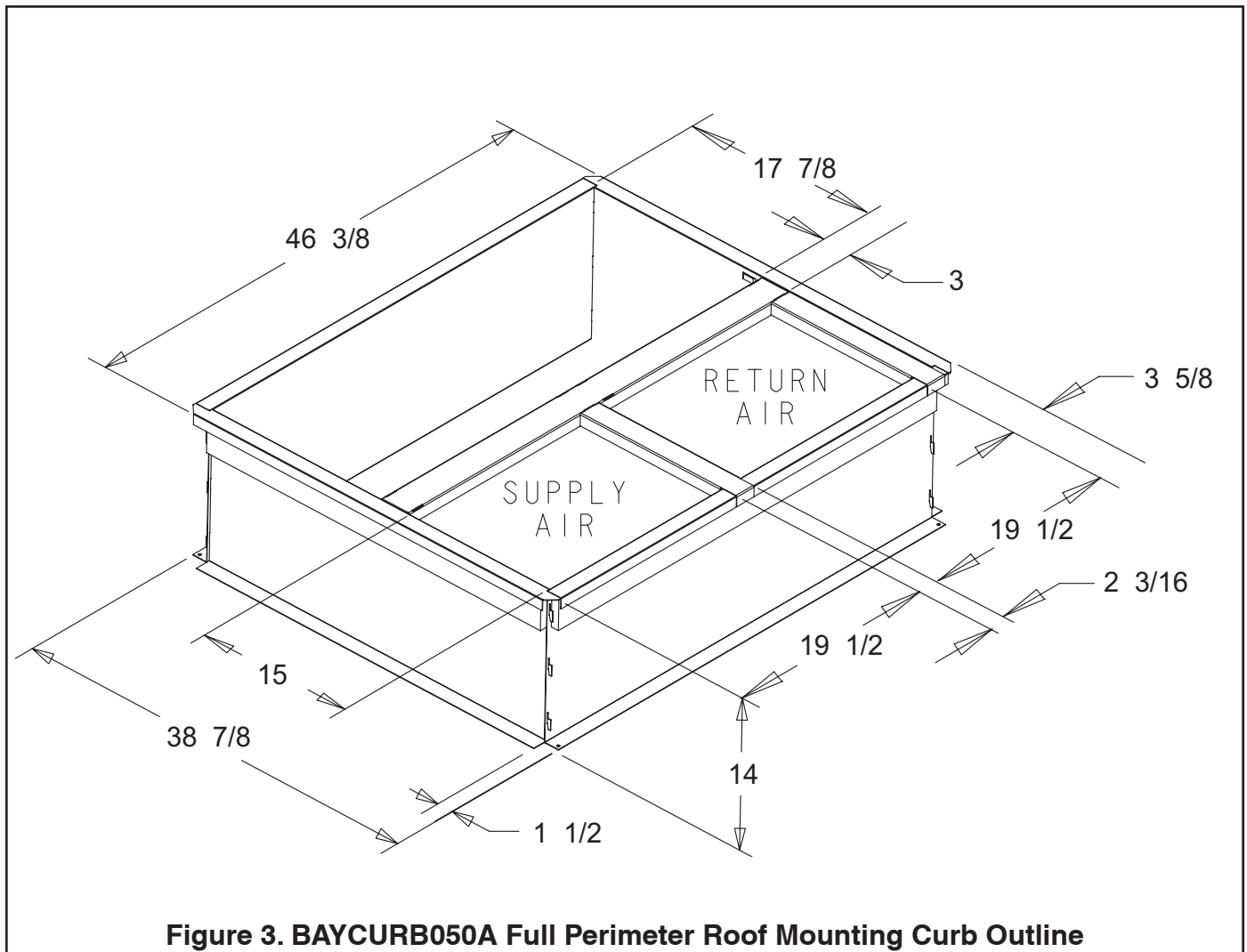

BAYCURB050A Roof Mounting Curb Assembly

1. Remove the components of the mounting curb from packing and separate pieces from each other.
2. Lay separate pieces on flat surface close to area where it will be used. See illustration below to determine proper placement of parts. Assemble by snapping the tabs on Channel End Rails, into the slots on Channel Side Rails, the mating parts of the mounting curb.
3. Set supports A, B, and C onto channel sides and channel ends as shown in Figure 4 (below).

IMPORTANT: The BAYCURB050A does not have insulation on inside perimeter of curb. To prevent condensation from forming on the inside surface of the curb, insulate and seal the outside surface of the curb as illustrated in Figure 5, page 5. If the roof deck is removed or omitted from the entire inside area of the roof curb, insulation should be secured to the bottom of the unit base pan to prevent condensation from forming on the bottom of the base pan. Insulate the bottom of the condenser section of the unit base pan after the unit has been placed on the curb. Glue a 1" thick foil covered fiberglass duct board or equivalent to the bottom of the unit base pan, with foil side out. Use a good commercial grade of glue - not water based glue.

The BAYCURB050A Roof Mounting Curb is shipped disassembled with the components to be assembled on the job site as illustrated. This assembly includes the following components (check list before starting job).

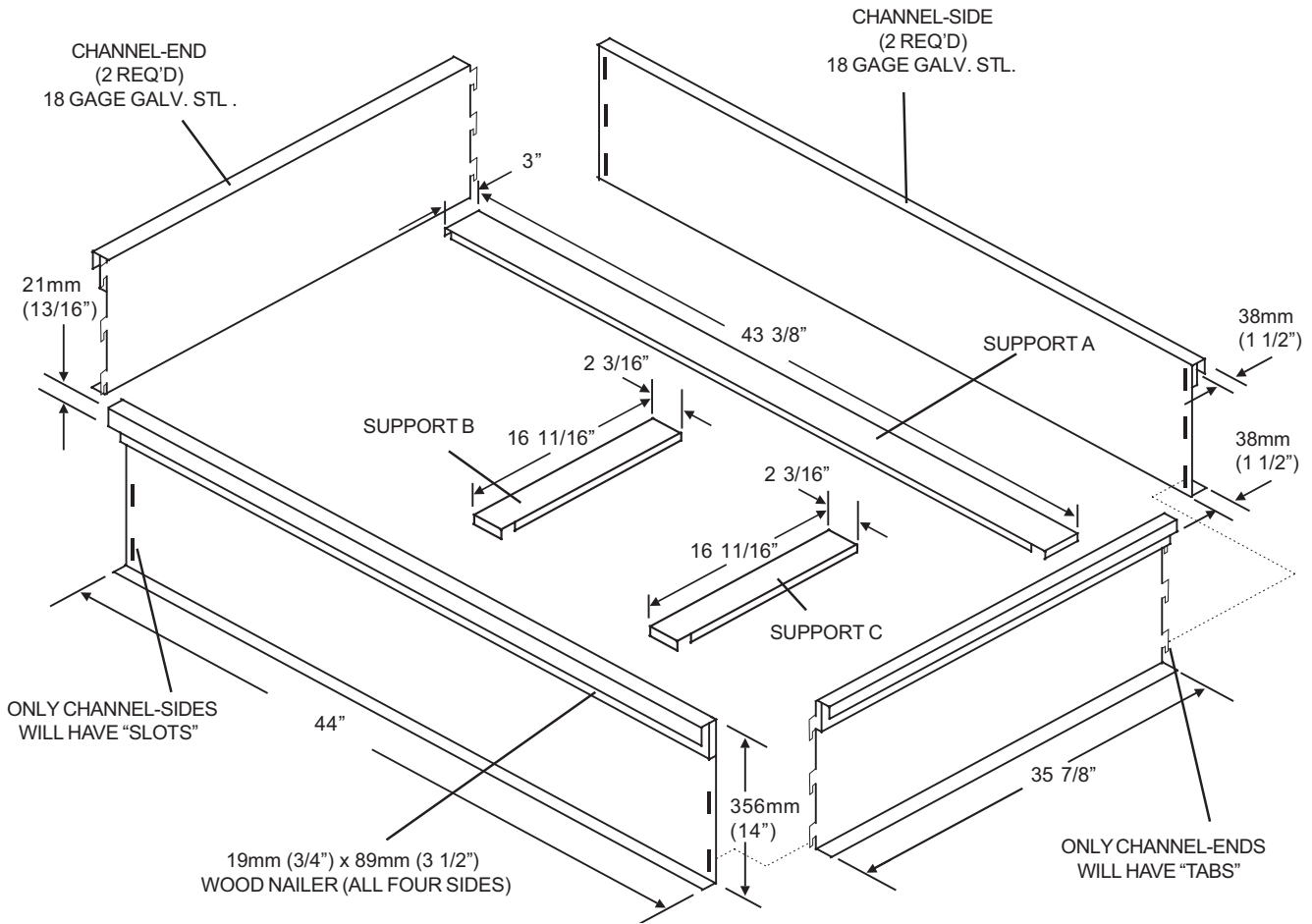

Figure 4. BAYCURB050A Component Drawing

Roof Mounting Curb

4. Place Mounting Curb assembly over hole cut in roof. Square the Curb by measuring from one corner diagonally to the opposite corner. Repeat this measurement of opposite corners and adjust the Curb until the measurements are the same.

NOTE: The top of the End Rails, Center Rail, Divider Baffle, and Adjustable Duct Flanges must be flush with the top of the Side Rails to insure a good water and air seal against the bottom of the unit. Caulk ends of adjustable duct Flanges and Divider Baffle to prevent air leakage.

5. Secure Mounting Curb assembly to roof structure by welding or bolting.

6. Install flashing and roofing in accordance with local codes. A typical section of insulation, roof, and mounting curb is shown below.

NOTE: If unit is not ready to be set into position at this time, stop work on mounting curb at this point. When unit is ready to set into position, and just prior to setting unit, complete installation.

7. Field Fabricated Ducts are to be installed from above mounting curb, they should be installed at this time. See Figures 6 (page 6) and 7 (page 7) for installation illustrations.

8. Apply a bead of architectural grade caulking (field supplied) at corners of curb to seal all voids, preventing water leaks.

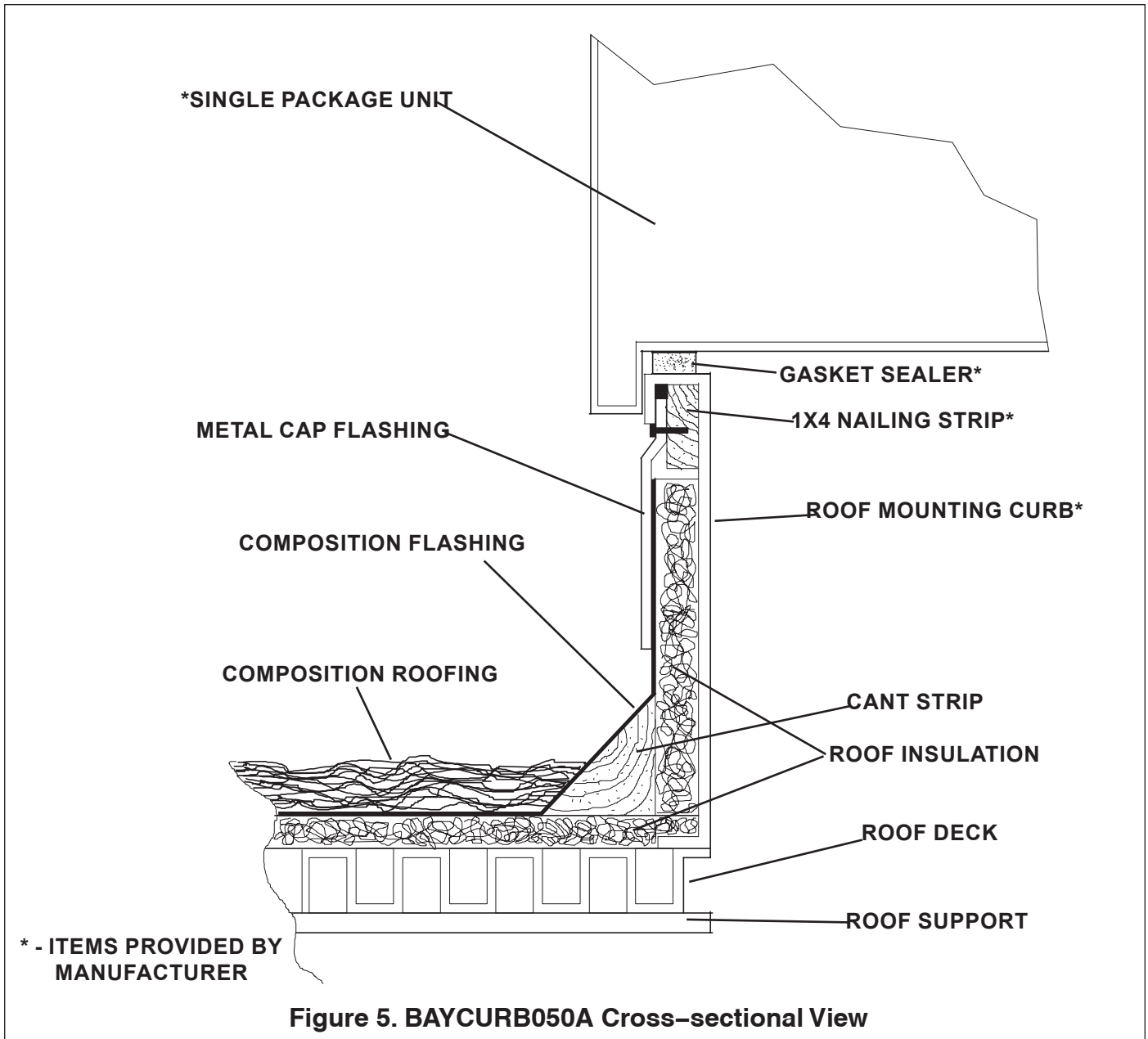
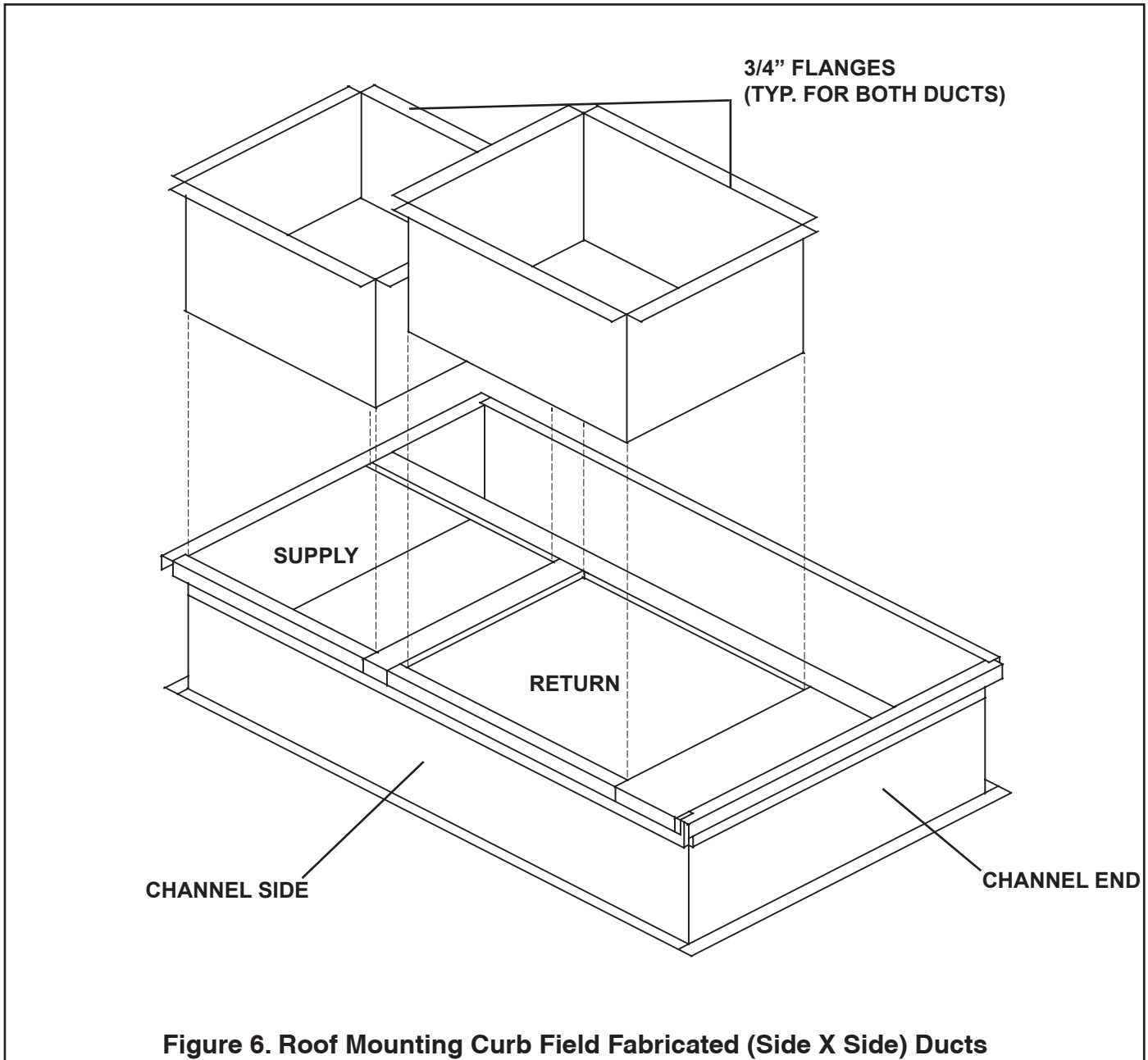

Figure 5. BAYCURB050A Cross-sectional View

Roof Mounting Curb Field Fabricated (Side X Side) Ducts

Side x Side Ducts Installed from Above Mounting Curb

Lower Field Fabricated Ducts into position on Duct Supports. See Figures 6 (below) and 7 (page7). Make assembly secure with sheet metal screws.



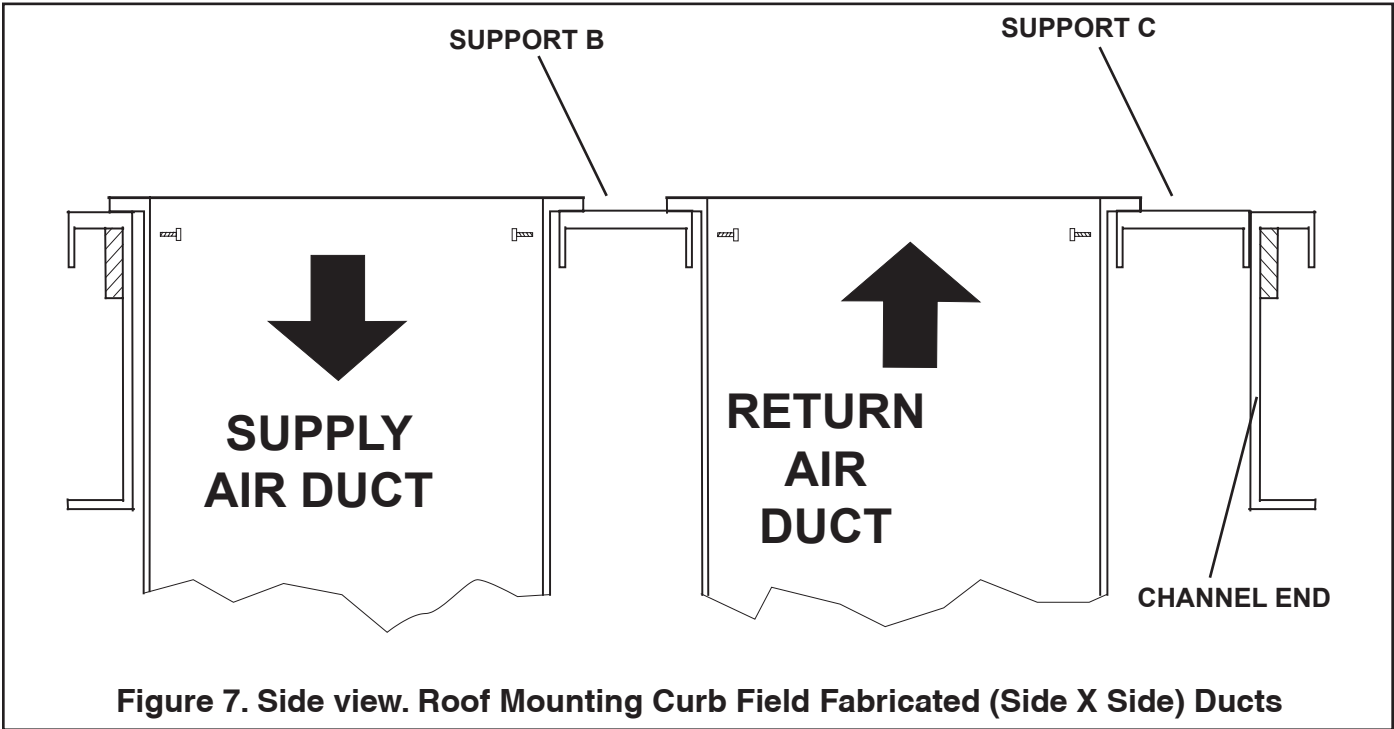

**Roof Mounting Curb (cont'd) P.V.C. Rubber Gasket
Position on BAYCURB for Unit Placement**

- 1. Install the optional insulated deck pan accessory kit (if required) on the curb before placing the 1-1/2" x 1/2" P.V.C. rubber tape (gasket) on mounting curb as illustrated. P.V.C. tape to be applied to curb as shown just prior to setting unit on the mounting curb.
- 2. P.V.C. rubber tape (supplied with curb) must be applied in continuous strips of overlapped 1" minimum for complete watertight seal.

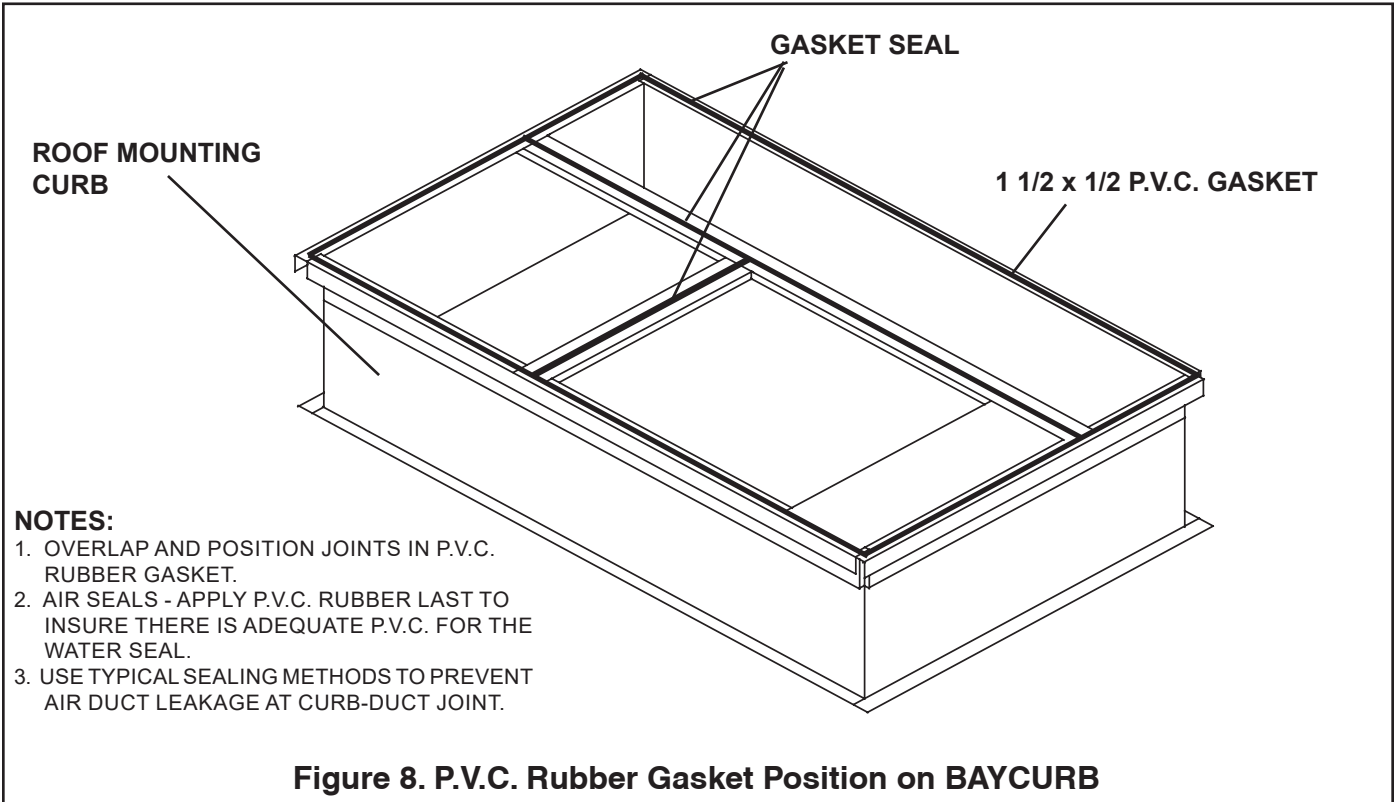

About Trane and American Standard Heating and Air Conditioning

Trane and American Standard create comfortable, energy efficient indoor environments for residential applications. For more information, please visit www.trane.com or www.americanstandardair.com

The manufacturer has a policy of continuous data improvement and it reserves the right to change design and specifications without notice. We are committed to using environmentally conscious print practices.

18-HE38D9-5A-EN 10 Jul 2020
Supersedes 18-HE38D9-5 (March 2007)

© 2020