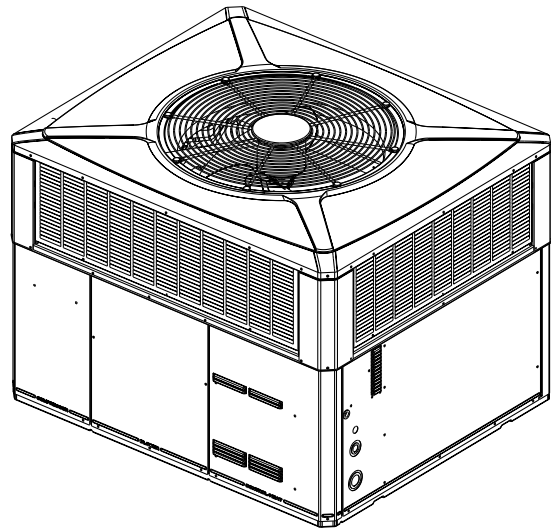


# Product Data

## Single Packaged Cooling/Electric Heat 14 SEER Convertible, 2 – 5 Ton

4TCC4024A1000A  
4TCC4030A1000A  
4TCC4036A1000A  
4TCC4042A1000A  
4TCC4048A1000A  
4TCC4060A1000A



*Note: "Graphics in this document are for representation only. Actual model may differ in appearance."*

## Table of Contents

Single Packaged Cooling/Electric Heat System.....	3
Optional Equipment Listing.....	4
Product Specifications.....	6
Supplementary Electric Heaters.....	9
Indoor Fan Performance (230v).....	10
Wiring Diagrams.....	14
Full Perimeter Roof Mounting Curb.....	18
Optional Equipment — Economizer.....	20
Optional Equipment — Outside Air Damper.....	21
Optional Equipment — Filter Rack.....	22
Outline Drawings.....	23
Mechanical Specifications.....	29

## Single Packaged Cooling/Electric Heat System

American Standard Heating & Air Conditioning offers a complete family of cooling systems designed to give you the unbeatable combination of energy efficiency and lower operating costs.

### **Introducing the new American Standard Heating & Air Conditioning Single Cooling/Electric Heat System**

**Single Packaged Cooling Systems are easy and versatile to install.**

Because cooling and air handling functions are all contained in a single cabinet, American Standard Heating & Air Conditioning packaged air conditioners are easy to install and service. It can be flush mounted beside your home at ground level or placed on the roof for horizontal or downflow installation. When connected to an optional American Standard Heating & Air Conditioning thermostat control, and air distribution ducts, you have a highly efficient, total home comfort system.

**Single Packaged Cooling Systems are unmatched in quality and reliability.**

All major components on these products, including the compressor, have been designed and manufactured for maximum service. Every compressor is designed and manufactured to exacting specifications. Each design is life tested in extreme environments to ensure reliable and long lasting operation in normal applications. Each compressor has internal motor protection for added reliability.

## Optional Equipment Listing

* = T, W, or Y	
Hinged Filter Access Door (4*CC4024-036) (4*CY4024-4036)	BAYCCDOR1A [ ]
Hinged Filter Access Door (4*CC4042-060) (4*CY4042-4060)	BAYCCDOR2A [ ]
Roof Curb Full Perimeter (4*CC024-036A) (4*CY4024-4036)	BAYCURB050A [ ]
Roof Curb Full Perimeter (4*CC042-060A) (4*CY4042-4060)	BAYCURB051A [ ]
Roof Curb Utility Extension Kit (BAYCURB050A)	BAYUTIL101B [ ]
Roof Curb Utility Extension Kit (BAYCURB051A)	BAYUTIL101B [ ]
0-25% Manual Fresh Air Damper (4*CC4024-36A) (4*CY4024-4036) <sup>(a)</sup>	BAYOSAH001A [ ]
0-25% Manual Fresh Air Damper (4*CC4042-60A) (4*CY4042-4060) <sup>(a)</sup>	BAYOSAH002A [ ]
Motorized Fresh Air Damper (4*CC4024-036A) (4*CY4024-4036) <sup>(a)</sup>	BAYDMPR101A [ ]
Motorized Fresh Air Damper (4*CC4042-060A) (4*CY4042-4060) <sup>(a)</sup>	BAYDMPR102A [ ]
16" Round Duct Adapter (2 per box) (4*CC4024-036A) (4*CY4024-4036) <sup>(b)</sup>	BAYSQRD001A [ ]
18" Round Duct Adapter (2 per box) (4*CC4024-060A) (4*CY4024-4036) <sup>(b)</sup>	BAYSQRD002A [ ]
0-100% Mod Economizer w/Baro. Relief (4*CC4024-036A) (4*CY4024-4036) <sup>(a)(c)(d)</sup>	BAYECON101B [ ]
0-100% Mod Economizer w/Baro. Relief (4*CC4042-060A) (4*CY4042-4060) <sup>(a)(d)</sup>	BAYECON102B [ ]
0-100% Horizontal Economizer (4*CC4024-36A) (4*CY4024-4036) <sup>(a)</sup>	BAYECON200B [ ]
0-100% Horizontal Economizer (4*CC4042-60A) (4*CY4042-4060) <sup>(a)</sup>	BAYECON201B [ ]
Enthalpy Control for Economizer (ALL-BAYECON)	BAYEENTH001A [ ]
Remote Potentiometer (ALL-BAYECON)	BAYSTAT023 [ ]
1"–2" Filter Frame (4*CC4024-036A) (4*CY4024-4036) (18 x 25 filter not included)	BAYFLTR101C [ ]
1"–2" Filter Frame (4*CC4042-060A) (4*CY4042-4060) (two 18 x 20 filters not included)	BAYFLTR201C [ ]
Head Pressure Control (Low Ambient Cool) (208/240v) Kit	BAYLOAM105A [ ]
Quick Start Kit (4WCC4-A1)(4TCC4-A1)	BAYQSTK300A [ ]
Quick Start Kit (4YCC4-A1)	BAYQSTK301A [ ]
Crankcase Heater Scroll (4*CC4024-036) (4*CY4024-4036) (230v)	BAYCCHT103A [ ]
Crankcase Heater Scroll (4*CC4042-060) (4*CY4042-4060) (230v)	BAYCCHT102A [ ]
Crankcase Heater Scroll (4*CC4024-036) (4*CY4024-4036) (230v)	BAYCCHT301A [ ]
Crankcase Heater Scroll (4*CC4042-060) (4*CY4042-4060) (230v)	BAYCCHT302A [ ]
Adapter Curb (4*CC4024-36A) (4*CY4024-4036A) to BAYCURB030,38	BAYADAP050A [ ]
Adapter Curb (4*CC4024-36A) (4*CY4024-4036A) to BAYCURB033	BAYADAP051A [ ]
Adapter Curb (4*CC4042-60A) (4*CY4042-4060A) to BAYCURB030,38	BAYADAP052A [ ]
Adapter Curb (4*CC4042-60A) (4*CY4042-4060A) to BAYCURB033	BAYADAP053A [ ]
Adapter Curb (4*CC4042-60A) (4*CY4042-4060A) to BAYCURB034	BAYADAP054A [ ]
12" Duct Shroud Covers Horizontal (4*CC4024-060A) (4*CY4024-4060A)	BAYCOVR112A [ ]
18" Duct Shroud Covers Horizontal (4*CC4024-060A) (4*CY4042-4060A)	BAYCOVR118A [ ]
Extreme Condition Mounting Kit — All BAYCURB & BAYADAP	BAYEXMK001A [ ]
Extreme Condition Mounting Kit — All BAYUTIL	BAYEXMK002B [ ]
Extreme Condition Mounting Kit — All Slab Mounts	BAYEXMK003B [ ]
Lifting Lug Kit	BAYLIFT002B [ ]
LP Conversion Kit (All 115K Models)	BAYLPKT100A [ ]
LP Conversion Kit (All 60K and 90K Models)	BAYLPKT101A [ ]
LP Conversion Kit (All 70K Models)	BAYLPKT102A [ ]
<b>SUPPLEMENTARY HEATERS (1 PHASE) * = T or W Only (Does not apply to Gas/Electric dual fuel models)</b>	
3.76/5.0 KW Heater (208/240V 1 PH) (4*CC4024-060A1)	BAYHTRV105F [ ]
6.0/8.0 KW Heater (208/240V 1 PH) (4*CC4024-060A1)	BAYHTRV108F [ ]
7.50/10.0 KW Heater (208/240V 1 PH) (4*CC4024-060A1)	BAYHTRV110F [ ]
11.27/15.0 KW Heater (208/240V 1 PH) (4*CC4030-060A1)	BAYHTRV115F [ ]
15.0/20.0 KW Heater (208/240V 1 PH) (4*CC4048-060A1)	BAYHTRV120F [ ]
18.78/25.0 KW Heater (208/240V 1 PH) (4*CC40060A1)	BAYHTRV125F [ ]

**Optional Equipment Listing**

<b>SUPPLEMENTARY HEATERS (3 PHASE) * = T or W Only (Does not apply to Gas/Electric dual fuel models)</b>	
3.76/5.0 KW Heater (208/240V 3 PH) (4WCY4036-060A3)	BAYHTRV305F [ ]
3.76/5.0 KW Heater (208/240V 3 PH) (4WCY4036-060A3)	BAYHTRV308F [ ]
7.50/10.0 KW Heater (208/240V 3 PH) (4WCY4024-048A3)	BAYHTRV310F [ ]
11.27/15.0 KW Heater (208/240V 3 PH) (4WCY4036-060A3)	BAYHTRV315F [ ]
15.0/20.0 KW Heater (208/240V 3 PH) (4WCY4048-060A3)	BAYHTRV320F [ ]
18.78/25.0 KW Heater (208/240V 3 PH) (4WCY4048-060A1)	BAYHTRV325F [ ]
Single Power Entry Kit (e)	BAYSPEK060F [ ]
Single Power Entry Kit (e)	BAYSPEK061E [ ]
Single Power Entry Kit (e)	BAYSPEK062F [ ]
Single Power Entry Kit (e)	BAYSPEK063F [ ]
Single Power Entry Kit (e)	BAYSPEK064E [ ]
Single Power Entry Kit (e)	BAYSPEK065E [ ]

- (a) Must use internal filter frame when economizer or fresh air kit is used.
- (b) It is the responsibility of the installing dealer to properly size the ductwork for each specific application.
- (c) Dry bulb control standard with economizer.
- (d) Downflow only.
- (e) Must be selected per unit and heater model

## Product Specifications

MODEL	4TCC4024A1000A	4TCC4030A1000A	4TCC4036A1000A
RATED Volts/Ph/Hz	208-230/1/60	208-230/1/60	208-230/1/60
Performance Cooling BTUH <sup>(a)</sup>	24600	28200	37000
Indoor Airflow (CFM)	805	870	1190
Power Input (KW)	1.99	2.39	3.08
EER/SEER (BTU/Watt-Hr.) <sup>(b)</sup>	12.0 / 14.00	12.0 / 14.00	12.0 / 14.00
Sound Power Rating [dB(A)] <sup>(c)</sup>	66.6	70	69.3
<b>POWER CONN. — V/Ph/Hz</b>	208-230/1/60	208-230/1/60	208-230/1/60
Min. Brch. Cir. Ampacity <sup>(d)</sup>	19.1	22.6	24.5
Fuse Size — Max. (amps)	30	35	40
Fuse Size — Recmd. (amps)	30	35	40
<b>COMPRESSOR</b>	SCROLL	SCROLL	SCROLL
Volts/Ph/Hz	208-230/1/60	208-230/1/60	208-230/1/60
R.L. Amps — L.R. Amps	12.8 / 58.0	14.1 / 73.0	15.4 / 83.9
<b>OUTDOOR COIL — TYPE</b>	SPINE-FIN	SPINE-FIN	SPINE-FIN
Rows/F.P.I	2 / 24	2 / 24	2 / 24
Face Area (sq. ft.)	13.32	13.32	15.49
Tube Size (in.)	3/8	3/8	3/8
<b>INDOOR COIL — TYPE</b>	MCHE	MCHE	MCHE
Rows/F.P.I	2 / 16	2 / 16	2 / 16
Face Area (sq. ft.)	2.7	2.7	2.7
Tube Size (in.)	.81	.81	1.00
Refrigeration Control	EXPANSION VALVE	EXPANSION VALVE	EXPANSION VALVE
Drain Conn. Size (in.)	3/4 FEMALE NPT	3/4 FEMALE NPT	3/4 FEMALE NPT
<b>OUTDOOR FAN — TYPE</b>	PROPELLER	PROPELLER	PROPELLER
DIA. (IN.)	23.4	23.4	23.4
DRIVE/NO. SPEEDS	DIRECT / 1	DIRECT / 1	DIRECT / 1
CFM @ 0.0 in. w.g. <sup>(e)</sup>	2350	2800	3080
Motor — HP/R.P.M	1 / 12 / 810	1 / 6 / 825	1 / 5 / 825
Volts/Ph/Hz	208-230/1/60	208-230/1/60	208-230/1/60
F.L. Amps/L.R Amps	.54 / .82	.85 / 1.65	1.1 / 2.0
<b>INDOOR FAN — TYPE</b>	CONSTANT TORQUE ECM	CONSTANT TORQUE ECM	CONSTANT TORQUE ECM
Dia. x Width (in.)	10.62 X 10.62	10.62 X 10.62	10.62 X 10.62
Drive/No. Speeds	DIRECT / 3	DIRECT / 3	DIRECT / 3
CFM @ 0.0 in. w.g. <sup>(f)</sup>	SEE FAN PERF TABLE	SEE FAN PERF TABLE	SEE FAN PERF TABLE
Motor — HP/R.P.M.	1/3 / 1050	1/2 / 1050	1/2 / 1050
Volts/Ph/Hz	208-230/1/60	208-230/1/60	208-230/1/60
F.L. Amps	2.6	4.1	4.1
<b>FILTER / FURNISHED</b>	NO	NO	NO
Type Recommended	THROWAWAY	THROWAWAY	THROWAWAY
Recmd. Face Area (sq. ft) <sup>(g)</sup>	4.0	4.0	4.0
<b>REFRIGERANT</b>	R-410	R-410	R-410
Charge (lbs.)	5.24	6.94	7.2
<b>CHARGING SPECIFICATIONS</b>			
Subcooling	12°	11°	11°
<b>DIMENSIONS</b>	H X D X W	H X D X W	H X D X W
Crated (in.)	46 X 45 X 52	46 X 45 X 52	48 X 45 X 52

Product Specifications

WEIGHT			
Shipping (lbs.) / Net (lbs.)	432 / 358	451 / 377	453 / 379

- (a) Rated in accordance with AHRI Standard 210/240.  
 (b) Rated in accordance with D.O.E. test procedure.  
 (c) Sound Power values are not adjusted for AHRI 270-95 tonal corrections.  
 (d) Calculated in accordance with currently prevailing Nat'l Electrical Code.  
 (e) Standard Air — Dry Coil — Outdoor.  
 (f) Standard Air — Dry Coil — Indoor  
 (g) Filters must be installed in return air stream. Square footages listed are based on 300 f.p.m. face velocity. If permanent filters are used size per manufacturer's recommendation with a clean resistance of 0.05" W.C.

MODEL	4TCC4042A1000A	4TCC4048A1000A	4TCC4060A1000A
RATED Volts/Ph/Hz	208-230/1/60	208-230/1/60	208-230/1/60
Performance Cooling BTUH (a)	40500	46500	58000
Indoor Airflow (CFM)	1450	1600	1760
Power Input (KW)	3.40	4.09	4.94
EER/SEER (BTU/Watt-Hr.) (b)	12.0 / 14.00	11.5 / 14.00	11.5 / 14.00
Sound Power Rating [dB(A)] (c)	74.6	72.5	73.1
<b>POWER CONN. — V/Ph/Hz</b>	208-230/1/60	208-230/1/60	208-230/1/60
Min. Brch. Cir. Ampacity (d)	28.5	32.0	39.1
Fuse Size — Max. (amps)	45	50	60
Fuse Size — Recmd. (amps)	45	50	60
<b>COMPRESSOR</b>	SCROLL	SCROLL	SCROLL
Volts/Ph/Hz	208-230/1/60	208-230/1/60	208-230/1/60
R.L. Amps — L.R. Amps	16.7 / 109	19.6 / 130.0	24.4 / 144.2
<b>OUTDOOR COIL — TYPE</b>	SPINE-FIN	SPINE-FIN	SPINE-FIN
Rows/F.P.I	2 / 24	2 / 24	2 / 24
Face Area (sq. ft.)	15.63	20.54	22.99
Tube Size (in.)	3/8	3/8	3/8
<b>INDOOR COIL — TYPE</b>	MCHE	MCHE	PLATE FIN
Rows/F.P.I	2 / 16	2 / 16	4 / 15
Face Area (sq. ft.)	3.9	3.9	5.0
Tube Size (in.)	.81	.81	3/8
Refrigeration Control	EXPANSION VALVE	EXPANSION VALVE	EXPANSION VALVE
Drain Conn. Size (in.)	3/4 FEMALE NPT	3/4 FEMALE NPT	3/4 FEMALE NPT
<b>OUTDOOR FAN — TYPE</b>	PROPELLER	PROPELLER	PROPELLER
DIA. (IN.)	28.25	28.25	28.25
DRIVE/NO. SPEEDS	DIRECT / 1	DIRECT / 1	DIRECT / 1
CFM @ 0.0 in. w.g. (e)	3400	3400	4800
Motor — HP/R.P.M	1 / 4 / 825	1 / 4 / 825	1 / 3 / 825
Volts/Ph/Hz	208-230 / 1 / 60	208-230 / 1 / 60	208-230/1/60
F.L. Amps/L.R Amps	1.51 / 3.07	1.51 / 3.07	1.7 / 3.5
<b>INDOOR FAN — TYPE</b>	CONSTANT TORQUE ECM	CONSTANT TORQUE ECM	CONSTANT TORQUE ECM
Dia. x Width (in.)	10.62 X 10.62	10.62 X 10.62	10.62 X 10.62
Drive/No. Speeds	DIRECT / 3	DIRECT / 3	DIRECT / 3
CFM @ 0.0 in. w.g. (f)	SEE FAN PERF TABLE	SEE FAN PERF TABLE	SEE FAN PERF TABLE
Motor — HP/R.P.M.	3/4 / 1050	3/4 / 1050	1 / 1050
Volts/Ph/Hz	208-230/1/60	208-230/1/60	208-230/1/60
F.L. Amps	6	6	6.9
<b>FILTER / FURNISHED</b>	NO	NO	NO
Type Recommended	THROWAWAY	THROWAWAY	THROWAWAY
Recmd. Face Area (sq. ft) (g)	5.3	5.3	5.3
<b>REFRIGERANT</b>	R-410	R-410	R-410
Charge (lbs.)	7.3	7.5	9.65
<b>CHARGING SPECIFICATIONS</b>			
Subcooling	10°	10°	11°

**Product Specifications**

<b>DIMENSIONS</b>	H X D X W	H X D X W	H X D X W
Crated (in.)	46 X 47 X 62	50 X 47 X 62	50 X 47 X 62
<b>WEIGHT</b>			
Shipping (lbs.) / Net (lbs.)	561 / 457	557 / 453	586 / 482

- (a) Rated in accordance with AHRI Standard 210/240.
- (b) Rated in accordance with D.O.E. test procedure.
- (c) Sound Power values are not adjusted for AHRI 270-95 tonal corrections.
- (d) Calculated in accordance with currently prevailing Nat'l Electrical Code.
- (e) Standard Air — Dry Coil — Outdoor.
- (f) Standard Air — Dry Coil — Indoor
- (g) Filters must be installed in return air stream. Square footages listed are based on 300 f.p.m. face velocity. If permanent filters are used size per manufacturer's recommendation with a clean resistance of 0.05" W.C.



## Supplementary Electric Heaters

UNIT MODEL	ELECTRIC HEATER MODEL	RATED VOLT-AGE	PHASE	AMPS	HEATER CAPACITY		NO. OF STAGES	KW/STAGE		MCA	MAX. FUSE OR HACR CKT BKR SIZE <sup>(a)</sup>	CANADA ONLY MAX. CKT BKR SIZE <sup>(b)</sup>
					KW	BTUH		1	2			
W/TC*3018-060#1 W/TCY4024-060#1 WCZ6036-060#1 *CC4018-060#1	BAYHTRV105	208/ 240	1	18/ 21	3.76/ 5.0	12800/ 17100	1	3.76/ 5.0	—	23/ 26	25/30	25/30
W/TC*3018-060#1 W/TCY4024-060#1 WCZ6036-060#1 *CC4018-060#1	BAYHTRV108	208/ 240	1	29/ 33	6.0/ 8.0	20500/ 27300	1	6.0/ 8.0	—	36/ 41	40/45	40/45
W/TC*3024-060#1 W/TCY4024-060#1 WCZ6036-060#1 *CC4024-060#1	BAYHTRV110	208/ 240	1	36/ 42	7.5/ 10.0	25600/ 34100	1	7.5/ 10.0	—	45/ 52	45/60	45/60
W/TC*3030-060#1 W/TCY4030-060#1 WCZ6036-060#1 *CC4030-060#1	BAYHTRV115	208/ 240	1	54/ 63	11.27/ 15.0	38500/ 51200	2	7.5/ 10.0	3.76/ 5.0	68/ 78	70/80	70/80
W/TC*3042-060#1 W/TCY4042-060#1 WCZ6048-060#1 *CC4042-060#1	BAYHTRV120#	208/ 240	1	72/ 83	15.0/ 20.0	51200/ 68300	2	7.5/ 10.0	7.5/ 10.0	90/ 104	90/110	90/110
WC*3042#1 W/TC3060#1 W/TCY4042-060#1 WCZ6048-060#1 *CC4060#1	BAYHTRV125#	208/ 240	1	90/ 104	18.78/ 25.0	51200/ 68300	2	11.26/ 15.0	7.5/ 10.0	113/ 130	125/150	125/150
W/TC*3036-060#3 W/TCY4036-060#3 WCZ6036-060#3 *CC4036-060#3	BAYHTRV305	208/ 240	3	10/ 12	3.76/ 5.0	64100/ 85300	1	3.76/ 5.0	—	13/ 15	15/15	15/15
W/TC*3036-060#3 W/TCY4036-060#3 WCZ6036-060#3 *CC4036-060#3	BAYHTRV308	208/ 240	3	17/ 19	6.0/ 8.0	20500/ 27300	1	6.0/ 8.0	—	21/ 24	25/25	25/25
W/TC*3036-060#3 W/TCY4036-060#3 WCZ6036-060#3 *CC4036-060#3	BAYHTRV310	208/ 240	3	21/ 24	7.5/ 10.0	25600/ 34100	1	7.5/ 10.0	—	26/ 30	30/30	30/30
W/TC*3036-060#3 W/TCY4036-060#3 WCZ6036-060#3 *CC4036-060#3	BAYHTRV315	208/ 240	3	31/ 36	11.27/ 15.0	38500/ 51200	2	7.5/ 10.0	3.76/ 5.0	39/ 45	40/45	40/45
W/TC*3048-060#3 W/TCY4048-060#3 WCZ6048-060#3 *CC4048-060#3	BAYHTRV320	208/ 240	3	42/ 48	15.0/ 20.0	51200/ 68300	2	7.5/ 10.0	7.5/ 10.0	52/ 60	60/60	60/60
W/TC*3060#3 W/TCY4048-060#3 WCZ6048-060#3 *CC4060#3	BAYHTRV325#	208/ 240	3	52/ 60	18.78/ 25.0	64100/ 85300	2	11.26/ 15.0	7.5/ 10.0	65/ 75	70/80	70/80
W/TC*3036-060#4 WCZ6036-060#4 *CC4036-60#4	BAYHTRV405	480	3	6	5.0	17100	1	5.0	—	8	15	15
W/TC*3036-060#4 WCZ6036-060#4 *CC4036-60#4	BAYHTRV408	480	3	10	8.0	27300	1	8.0	—	13	15	15
W/TC*3036-060#4 WCZ6036-060#4 *CC4036-60#4	BAYHTRV410	480	3	12	10.0	34100	1	10.0	—	15	15	15
W/TC*3036-060#4 WCZ6036-060#4 *CC4036-60#4	BAYHTRV415	480	3	18	15.0	51200	2	10.0	5.0	23	25	25
W/TC*3048-060#4 WCZ6048-060#4 *CC4048-60#4	BAYHTRV420	480	3	24	20.0	68300	2	10.0	10.0	30	30	30

## Supplementary Electric Heaters

W/TC*3060‡4 WCZ6048-060‡4 *CC4048-60‡4	BAYHTRV425	480	3	30	25.0	85300	2	15.0	10.0	38	40	40
<ol style="list-style-type: none"> <li>Any power supply and circuits must be wired and protected in accordance with local electrical codes.</li> <li>The values listed in the above table are for the electric heater only.</li> <li>Field wiring must be rated at least 75° C.</li> <li>* indicates an alpha character</li> <li>‡ indicates model letter</li> <li># Heater uses fuses</li> </ol> <p>ALL VALUES ARE FOR THE ELECTRIC HEATER ONLY</p>												

(a) The HACR circuit breaker is for U.S.A. installations only.  
(b) For Canada installation reference only.

## Indoor Fan Performance (230v)

**Table 1. Horizontal Airflow**

4TCC4024A1		EXTERNAL STATIC PRESSURE (IN. WG)										
MOTOR SPEED		0.0	0.1	0.2	0.3	0.4	0.5	0.6	0.7	0.8	0.9	1.0
COOLING — LOW	WATTS	84	91	98	105	113	119	123	126	132	-	-
	CFM	873	811	754	690	614	537	482	441	390	-	-
COOLING — MED	WATTS	107	114	121	128	138	147	152	157	161	-	-
	CFM	954	900	846	794	729	650	588	535	488	-	-
COOLING — HIGH	WATTS	135	142	150	158	167	175	185	191	196	-	-
	CFM	1041	993	938	890	836	777	707	644	594	-	-

**Table 2. Down Airflow**

4TCC4024A1		EXTERNAL STATIC PRESSURE (IN. WG)										
MOTOR SPEED		0.0	0.1	0.2	0.3	0.4	0.5	0.6	0.7	0.8	0.9	1.0
COOLING — LOW	WATTS	85	92	98	106	114	119	123	127	133	-	-
	CFM	865	803	746	683	608	532	478	436	386	-	-
COOLING — MED	WATTS	108	115	122	129	138	148	153	158	162	-	-
	CFM	945	891	838	786	722	643	582	530	483	-	-
COOLING — HIGH	WATTS	136	143	151	159	167	176	186	192	197	-	-
	CFM	1031	983	929	881	828	769	700	637	588	-	-

**Table 3. Horizontal Airflow**

4TCC4030A1		EXTERNAL STATIC PRESSURE (IN. WG)										
MOTOR SPEED		0.0	0.1	0.2	0.3	0.4	0.5	0.6	0.7	0.8	0.9	1.0
COOLING — LOW	WATTS	126	134	142	150	158	167	176	184	188	-	-
	CFM	1051	994	939	889	840	775	708	642	582	-	-
COOLING — MED	WATTS	166	175	184	192	200	209	219	230	239	-	-
	CFM	1156	1107	1054	1009	965	919	862	799	732	-	-
COOLING — HIGH	WATTS	221	230	240	250	259	268	278	289	-	-	-
	CFM	1278	1236	1187	1141	1099	1059	1017	968	-	-	-

Supplementary Electric Heaters

**Table 4. Down Airflow**

4TCC4030A1		EXTERNAL STATIC PRESSURE (IN. WG)										
MOTOR SPEED		0.0	0.1	0.2	0.3	0.4	0.5	0.6	0.7	0.8	0.9	1.0
COOLING — LOW	WATTS	126	135	143	150	158	168	177	184	189	-	-
	CFM	1041	984	930	880	831	768	701	635	576	-	-
COOLING — MED	WATTS	167	176	185	193	201	210	220	231	240	-	-
	CFM	1144	1096	1044	999	956	910	853	791	724	-	-
COOLING — HIGH	WATTS	222	231	241	251	260	270	279	290	-	-	-
	CFM	1266	1224	1175	1129	1088	1048	1007	959	-	-	-

**Table 5. Horizontal Airflow**

4TCC4036A1		EXTERNAL STATIC PRESSURE (IN. WG)										
MOTOR SPEED		0.0	0.1	0.2	0.3	0.4	0.5	0.6	0.7	0.8	0.9	1.0
COOLING — LOW	WATTS	247	254	262	269	277	285	291	300	311	-	-
	CFM	1131	1092	1058	1022	983	942	899	857	804	-	-
COOLING — MED	WATTS	339	350	358	366	374	383	391	399	386	-	-
	CFM	1256	1223	1193	1167	1136	1101	1065	1026	955	-	-
COOLING — HIGH	WATTS	471	479	488	497	506	499	454	406	-	-	-
	CFM	1402	1372	1344	1316	1289	1241	1144	1025	-	-	-

**Table 6. Down Airflow**

4TCC4036A1		EXTERNAL STATIC PRESSURE (IN. WG)										
MOTOR SPEED		0.0	0.1	0.2	0.3	0.4	0.5	0.6	0.7	0.8	0.9	1.0
COOLING — LOW	WATTS	246	255	263	271	278	285	293	301	312	-	-
	CFM	1124	1087	1053	1016	978	938	895	852	800	-	-
COOLING — MED	WATTS	343	351	359	367	376	384	392	400	379	-	-
	CFM	1249	1216	1185	1155	1122	1089	1054	1016	934	-	-
COOLING — HIGH	WATTS	476	485	493	501	508	488	449	398	-	-	-
	CFM	1390	1357	1329	1301	1273	1212	1125	1008	-	-	-

**Table 7. Horizontal Airflow**

4TCC4042A1		EXTERNAL STATIC PRESSURE (IN. WG)										
MOTOR SPEED		0.0	0.1	0.2	0.3	0.4	0.5	0.6	0.7	0.8	0.9	1.0
COOLING — LOW	WATTS	224	233	242	252	262	272	283	295	305	319	-
	CFM	1358	1393	1348	1296	1253	1204	1157	1096	1057	988	-
COOLING — MED	WATTS	306	316	327	337	348	359	369	382	395	407	-
	CFM	1521	1490	1448	1391	1362	1338	1315	1307	1254	1148	-
COOLING — HIGH	WATTS	409	421	432	443	455	467	477	490	503	513	-
	CFM	1659	1637	1604	1594	1529	1491	1467	1425	1385	1345	-

**Table 8. Down Airflow**

4TCC4042A1		EXTERNAL STATIC PRESSURE (IN. WG)										
MOTOR SPEED		0.0	0.1	0.2	0.3	0.4	0.5	0.6	0.7	0.8	0.9	1.0

**Supplementary Electric Heaters**

**Table 8. Down Airflow (continued)**

COOLING — LOW	WATTS	228	238	247	257	267	278	289	301	312	325	-
	CFM	1345	1379	1334	1283	1241	1192	1145	1085	1046	979	-
COOLING — MED	WATTS	312	322	333	344	354	366	377	389	403	415	-
	CFM	1506	1475	1433	1377	1348	1325	1302	1293	1241	1136	-
COOLING — HIGH	WATTS	417	430	441	452	464	477	487	499	513	523	-
	CFM	1642	1621	1588	1578	1514	1476	1453	1411	1371	1331	-

Supplementary Electric Heaters

**Table 9. Horizontal Airflow**

4TCC4048A1		EXTERNAL STATIC PRESSURE (IN. WG)										
MOTOR SPEED		0.0	0.1	0.2	0.3	0.4	0.5	0.6	0.7	0.8	0.9	1.0
COOLING — LOW	WATTS	302	313	324	332	346	353	368	376	394	406	-
	CFM	1583	1542	1502	1460	1415	1371	1326	1282	1230	1181	-
COOLING — MED	WATTS	414	426	436	448	459	471	483	495	510	524	-
	CFM	1763	1723	1689	1648	1609	1568	1527	1488	1447	1404	-
COOLING — HIGH	WATTS	553	566	577	590	601	613	631	643	647	611	-
	CFM	1945	1910	1876	1839	1806	1769	1728	1688	1652	1545	-

**Table 10. Down Airflow**

4TCC4048A1		EXTERNAL STATIC PRESSURE (IN. WG)										
MOTOR SPEED		0.0	0.1	0.2	0.3	0.4	0.5	0.6	0.7	0.8	0.9	1.0
COOLING — LOW	WATTS	308	320	330	339	352	360	375	384	402	413.9	-
	CFM	1567	1526	1487	1445	1401	1358	1312	1270	1218	1169	-
COOLING — MED	WATTS	422	434	444	457	468	480	493	505	520	534	-
	CFM	1745	1706	1672	1632	1593	1552	1512	1473	1433	1390	-
COOLING — HIGH	WATTS	564	577	589	602	613	625	644	656	660	623	-
	CFM	1925	1890	1857	1821	1788	1751	1711	1671	1635	1530	-

**Table 11. Horizontal Airflow**

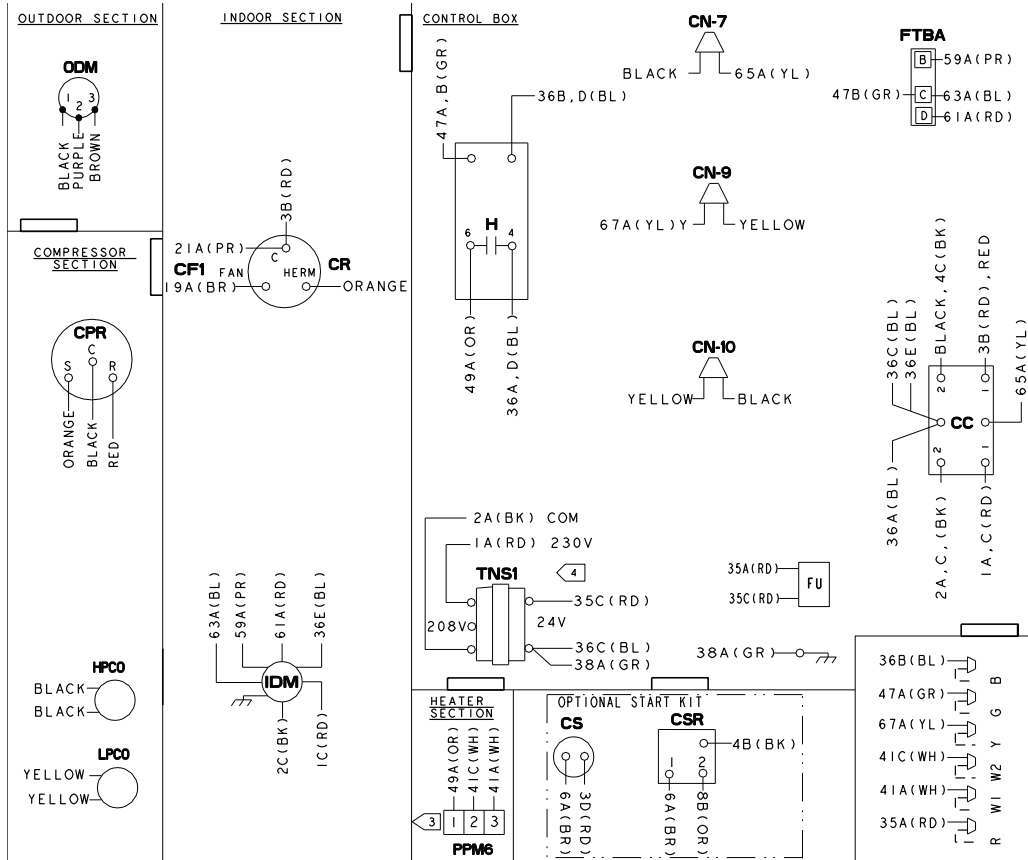
4TCC4060A1		EXTERNAL STATIC PRESSURE (IN. WG)										
MOTOR SPEED		0.0	0.1	0.2	0.3	0.4	0.5	0.6	0.7	0.8	0.9	1.0
COOLING — LOW	WATTS	515	523	533	544	554	569	582	595	-	-	-
	CFM	1857	1831	1800	1766	1737	1692	1655	1617	-	-	-
COOLING — MED	WATTS	749	759	769	779	788	803	816	830	845	860	-
	CFM	2083	2058	2032	2003	1974	1943	1911	1877	1843	1807	-
COOLING — HIGH	WATTS	900	910	921	932	941	956	969	983	997	1010	-
	CFM	2201	2177	2152	2127	2105	2071	2041	2009	1975	1940	-

**Table 12. Down Airflow**

4TCC4060A1		EXTERNAL STATIC PRESSURE (IN. WG)										
MOTOR SPEED		0.0	0.1	0.2	0.3	0.4	0.5	0.6	0.7	0.8	0.9	1.0
COOLING — LOW	WATTS	524	533	545	558	570	582	595	608	-	-	-
	CFM	1831	1802	1765	1728	1695	1662	1626	1586	-	-	-
COOLING — MED	WATTS	770	781	790	804	819	832	845	858	872	887	-
	CFM	2054	2030	2010	1976	1946	1911	1879	1848	1817	1781	-
COOLING — HIGH	WATTS	940	936	937	948	962	975	990	992	987	985	-
	CFM	2201	2151	2120	2095	2066	2033	1999	1967	1921	1871	-

## Wiring Diagrams

Figure 1. 4TCC4024 — 4042 Models



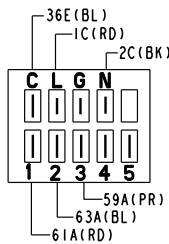
**NOTES:**

- 1 CONNECTIONS SHOWN ARE FOR A TYPICAL THERMOSTAT. SEE SCHEMATIC SUPPLIED WITH THERMOSTAT FOR PROPER CONNECTIONS. LOW VOLTAGE WIRING TO UNIT MAY BE NEC CLASS 2 AND MUST BE A MINIMUM OF 18 A.W.G.
2. MAXIMUM ADDITIONAL EXTERNAL LOAD (PILOT DUTY) BETWEEN "B" AND "R" OF 0.5 AMPS, 24 VAC IS AVAILABLE WHEN A HEATER IS INSTALLED.
- 3 SEE WIRING DIAGRAM WITH HEATER FOR DETAILS OF HEATER WIRING
- 4 FOR 208 VOLT OPERATION MAKE THE FOLLOWING WIRING CHANGES:  
A: AT COMPRESSOR CONTACTOR REMOVE IC(RD) WIRE FROM TNSI AND CONNECT TO TNSI AT 208V TERMINAL.
5. IF ANY OF THE ORIGINAL WIRE AS SUPPLIED IN THIS UNIT MUST BE REPLACED, REPLACE IT WITH APPLIANCE WIRING MATERIAL RATED AT 105° C.

ABBR	COLOR	ABBR	COLOR
BK	BLACK	PR	PURPLE
BL	BLUE	RD	RED
BR	BROWN	WH	WHITE
GR	GREEN	YL	YELLOW
OR	ORANGE		

DEVICE	DESCRIPTION	LINE
AH, BH	CONTACTOR, ELECTRIC HEAT	39, 40
CC	COMPRESSOR CONTACTOR COIL	43
CFI	OUTDOOR FAN CAPACITOR	24
CN	CONNECTOR OR WIRE NUT	
CPR	COMPRESSOR	20
CR	COMPRESSOR RUN CAPACITOR	20
CS	COMPRESSOR START CAPACITOR	15
CSR	COMPRESSOR START RELAY COIL	15
H	ELECTRIC HEAT RELAY	45
FTB	FAN TERMINAL BLOCK	28, 29
IDM	INDOOR FAN MOTOR	28
IOL	INTERNAL OVERLOAD	
ODM	OUTDOOR FAN MOTOR	24
PCD	PRINTED CIRCUIT BOARD	45-47
PPM6	HEATER PLUG (FEMALE)	39, 40
TNS1	CONTROL POWER TRANSFORMER	34
HPCO	HIGH PRESSURE SWITCH	43
LPCO	LOW PRESSURE SWITCH	43
FU	FUSE	35

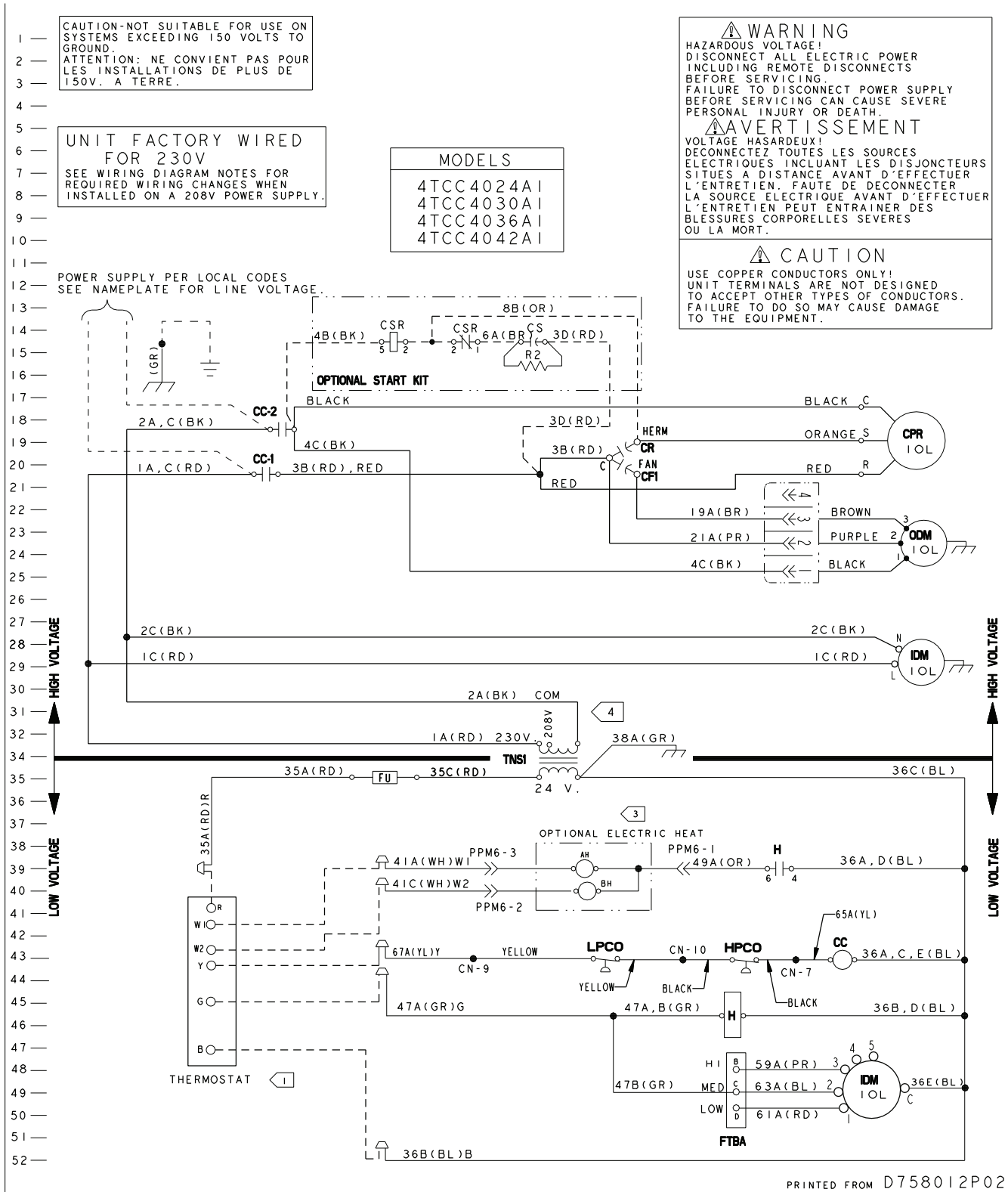
- C = LOW VOLTAGE COMMON
- G = ALTERNATE GROUND LOCATION
- L = LINE VOLTAGE
- N = NEUTRAL
- 1 = LOW TAP
- 2 = MEDIUM TAP
- 3 = HIGH TAP
- 4 = NOT USED
- 5 = NOT USED



**IDM CONNECTION**

Drawing no. D758012P01

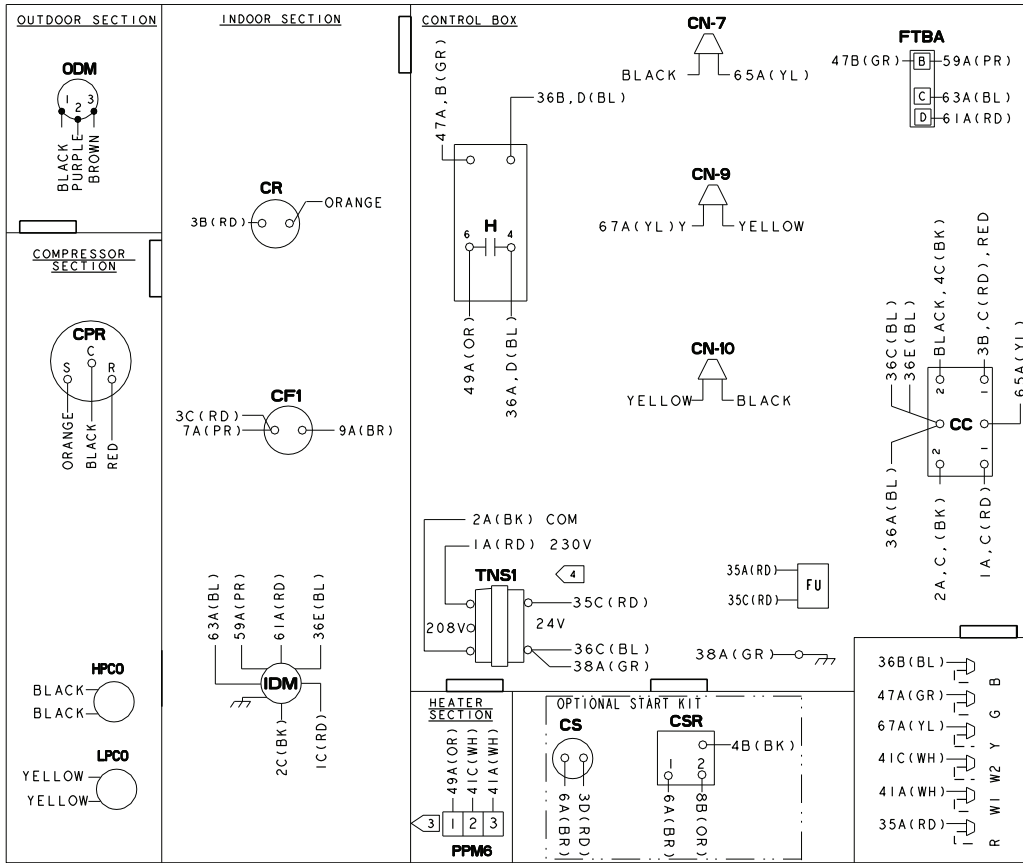
Figure 2. 4TCC4024 — 4042 Models Pg 2



PRINTED FROM D758012P02

**Wiring Diagrams**

**Figure 3. 4TCC4048 and 4060 Models**

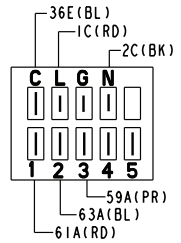


- NOTES:**
1. CONNECTIONS SHOWN ARE FOR A TYPICAL THERMOSTAT. SEE SCHEMATIC SUPPLIED WITH THERMOSTAT FOR PROPER CONNECTIONS. LOW VOLTAGE WIRING TO UNIT MAY BE NEC CLASS 2 AND MUST BE A MINIMUM OF 18 A.W.G.
  2. MAXIMUM ADDITIONAL EXTERNAL LOAD (PILOT DUTY) BETWEEN "B" AND "R" OF 0.5 AMPS, 24 VAC IS AVAILABLE WHEN A HEATER IS INSTALLED.
  3. SEE WIRING DIAGRAM WITH HEATER FOR DETAILS OF HEATER WIRING
  4. FOR 208 VOLT OPERATION MAKE THE FOLLOWING WIRING CHANGES:  
A. AT COMPRESSOR CONTACTOR REMOVE IC(RD) WIRE FROM TNS1 AND CONNECT TO TNS1 AT 208V TERMINAL.
  5. IF ANY OF THE ORIGINAL WIRE AS SUPPLIED IN THIS UNIT MUST BE REPLACED, REPLACE IT WITH APPLIANCE WIRING MATERIAL RATED AT 105° C.

ABBR	COLOR	ABBR	COLOR
BK	BLACK	PR	PURPLE
BL	BLUE	RD	RED
BR	BROWN	WH	WHITE
GR	GREEN	YL	YELLOW
OR	ORANGE		

C = LOW VOLTAGE COMMON  
G = ALTERNATE GROUND LOCATION  
L = LINE VOLTAGE  
N = NEUTRAL  
1 = LOW TAP  
2 = MEDIUM TAP  
3 = HIGH TAP  
4 = NOT USED  
5 = NOT USED

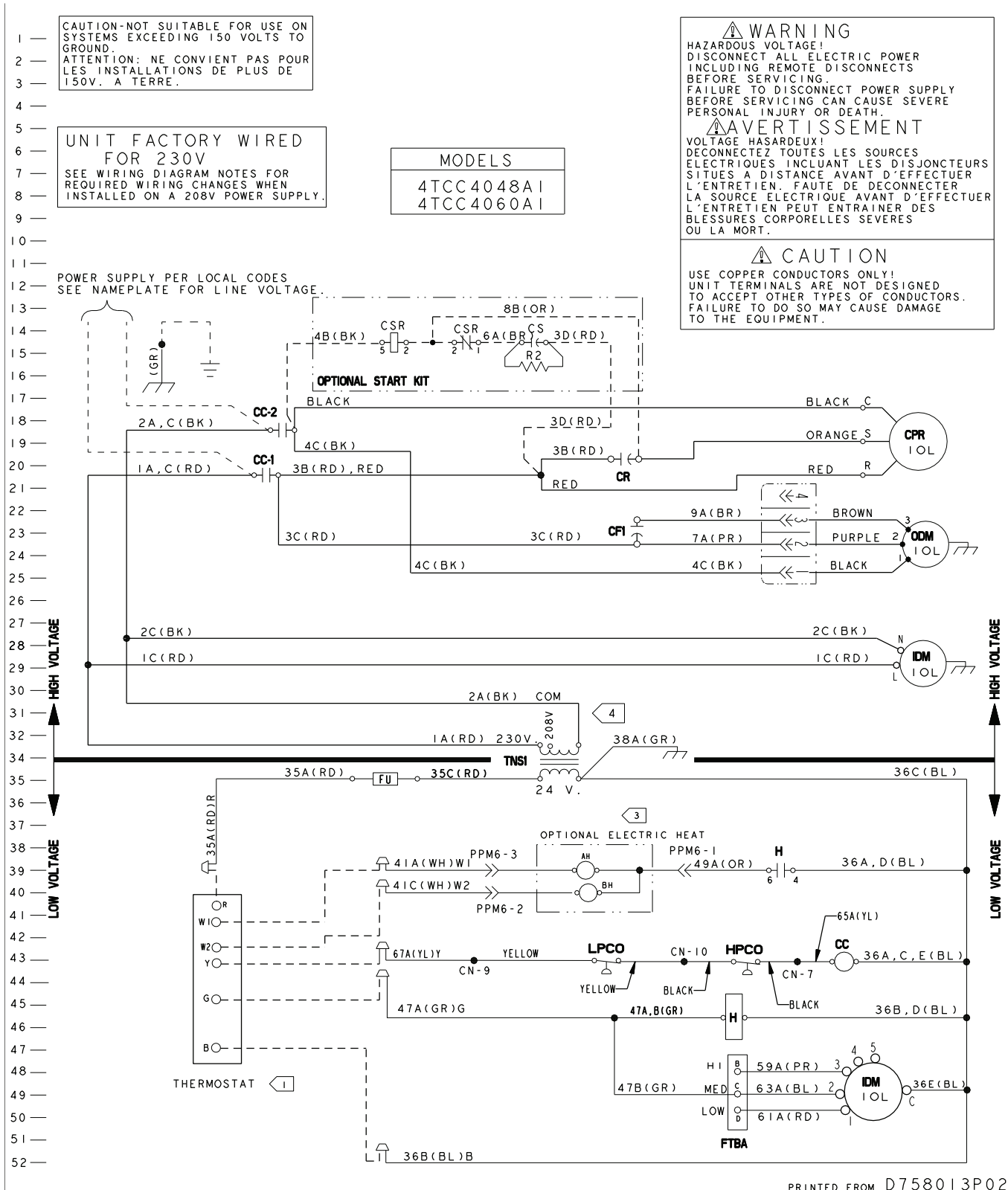
**IDM CONNECTION**



DEVICE	DESCRIPTION	LINE
AH, BH	CONTACTOR, ELECTRIC HEAT	39, 40
CC	COMPRESSOR CONTACTOR COIL	43
CF1	OUTDOOR FAN CAPACITOR	24
CN	CONNECTOR OR WIRE NUT	
CPR	COMPRESSOR	20
CR	COMPRESSOR RUN CAPACITOR	20
CS	COMPRESSOR START CAPACITOR	15
CSR	COMPRESSOR START RELAY COIL	15
H	ELECTRIC HEAT RELAY	45
FTB	FAN TERMINAL BLOCK	28, 29
IDM	INDOOR FAN MOTOR	28
IOL	INTERNAL OVERLOAD	
ODM	OUTDOOR FAN MOTOR	24
PCD	PRINTED CIRCUIT BOARD	45-47
PPM6	HEATER PLUG (FEMALE)	39, 40
TNS1	CONTROL POWER TRANSFORMER	34
HPCO	HIGH PRESSURE SWITCH	43
LPCO	LOW PRESSURE SWITCH	43
FU	FUSE	35



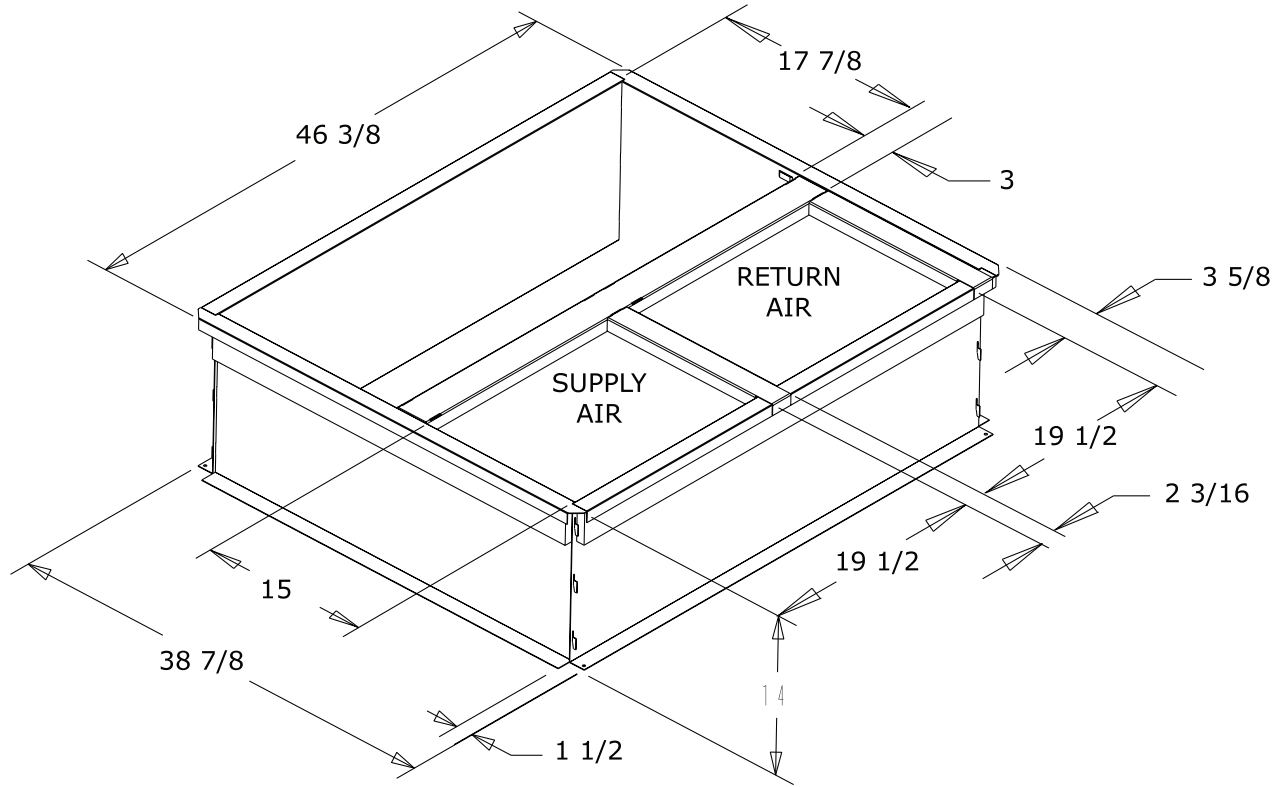
Figure 4. 4TCC4048 and 4060 Models Pg 2



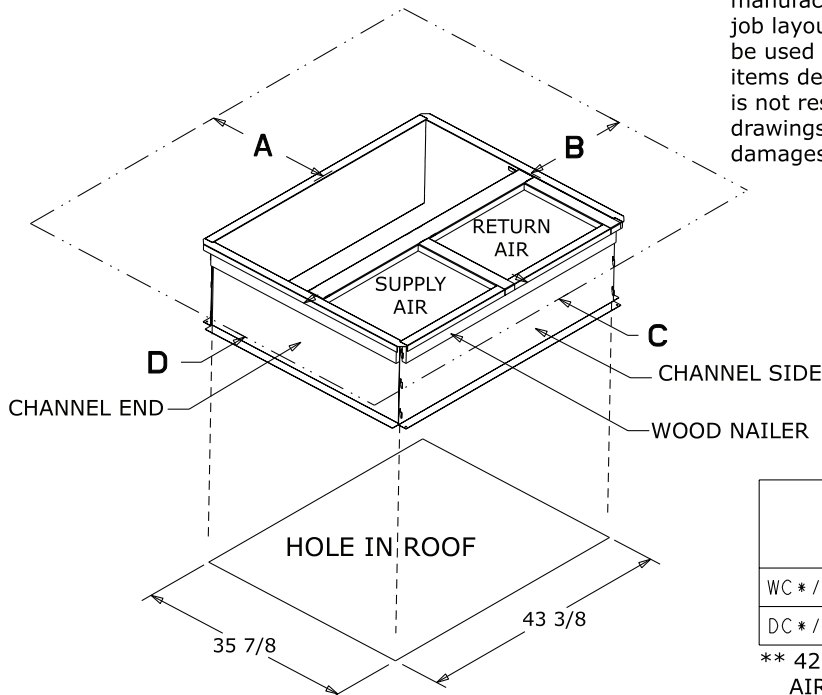
# Full Perimeter Roof Mounting Curb

Figure 5. 4024 – 4036 Models

## BAYCURB050A Full Perimeter Roof Mounting Curb



The drawings on this page are prepared by the manufacturer in order to provide detail regarding job layout only. These drawings are not intended to be used as a basis to construct, build or modify the items depicted in the drawings. The manufacturer is not responsible for the unauthorized use of these drawings and expressly disclaims any liability for damages resulting from such unauthorized use.



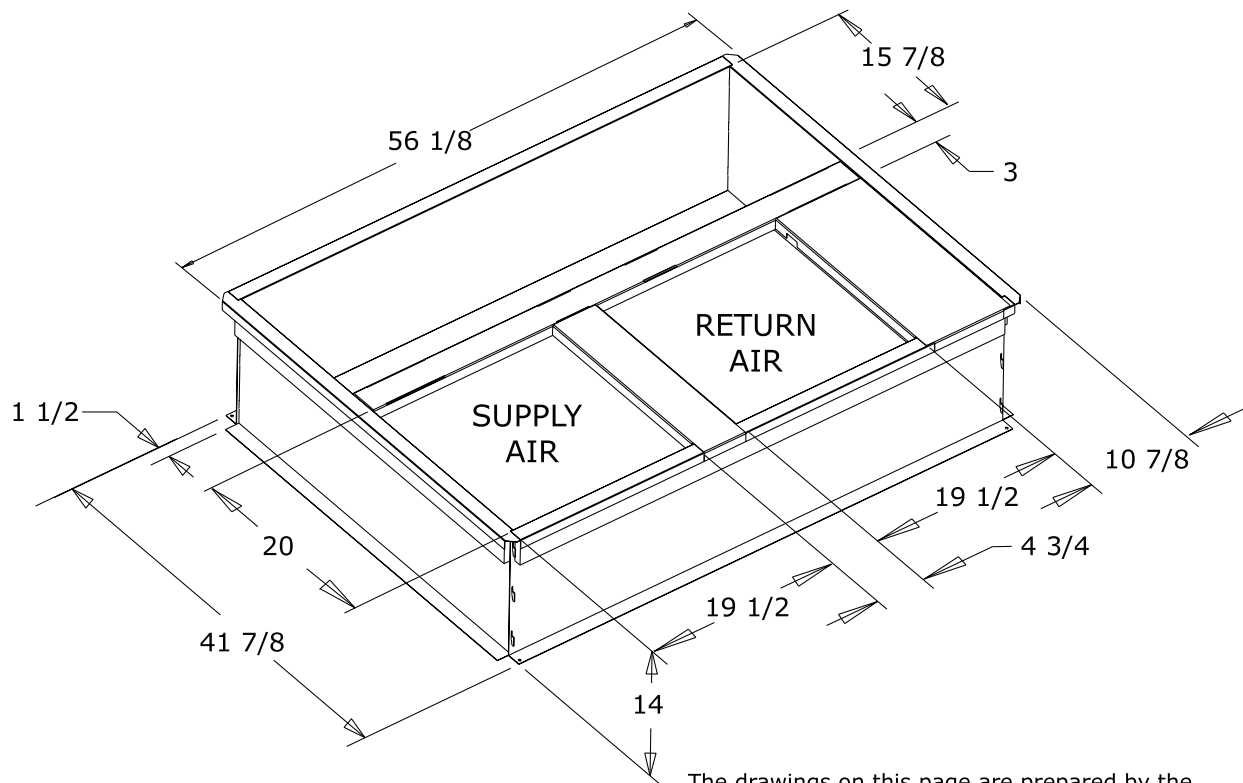
	SERVICE CLEARANCE DIMENSIONS			
	A	B	C	D
WC*/TC*	42.00	36.00	12.00**	24.00
DC*/YC*	42.00	36.00	12.00**	36.00

\*\* 42.00 WITH ECONOMIZER WITH 25% FRESH AIR ACCESSORY

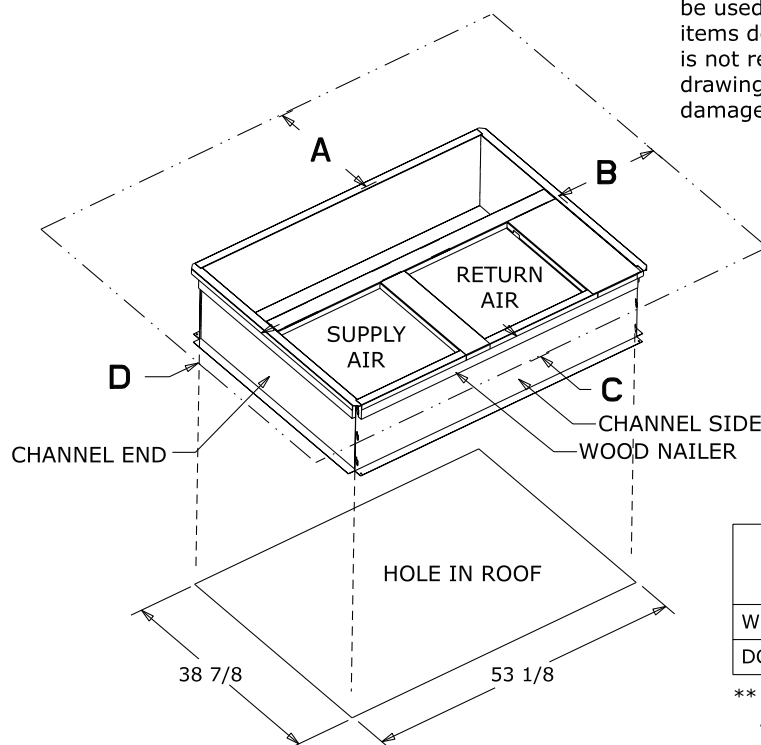
Full Perimeter Roof Mounting Curb

Figure 6. 4042 – 4060 Models

**BAYCURB051A Full Perimeter Roof Mounting Curb**



The drawings on this page are prepared by the manufacturer in order to provide detail regarding job layout only. These drawings are not intended to be used as a basis to construct, build or modify the items depicted in the drawings. The manufacturer is not responsible for the unauthorized use of these drawings and expressly disclaims any liability for damages resulting from such unauthorized use.



	SERVICE CLEARANCE DIMENSIONS			
	A	B	C	D
WC*/TC*	42.00	36.00	12.00**	24.00
DC*/YC*	42.00	36.00	12.00**	36.00

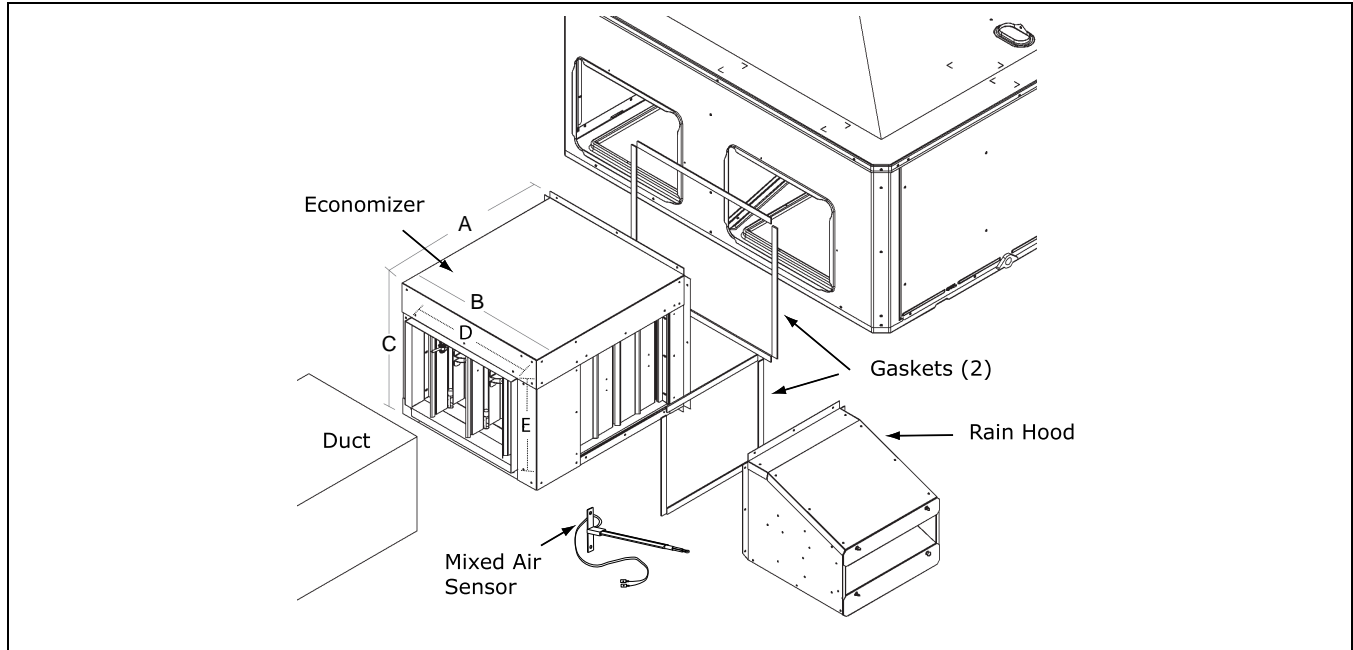
\*\* 42.00 WITH ECONOMIZER WITH 25% FRESH AIR ACCESSORY

## Optional Equipment – Economizer

**Table 13. BAYECON101,102A Down Discharge Economizer and Rain Hood (Mounts Over Horizontal Return Air Opening)**

	Economizer	Unit Application Models
	BAYECON101A	4024-036
	BAYECON102A	4042-060

**Table 14. BAYCON200, 201A Horizontal Economizer and Rain Hood**

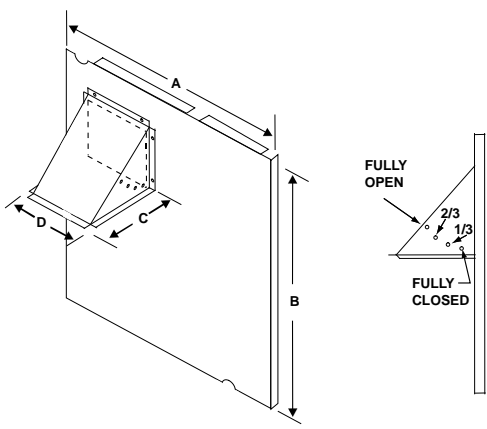


Economizer	Models	A	B	C	D	E	F
BAYECON200A	4024-4036	22"	20"	16-7/8"	15-11/16"	11-11/16"	15"
BAYECON201A	4042-4060	26"	22-21/32"	19"	17-11/16"	14-11/16"	21-3/8"

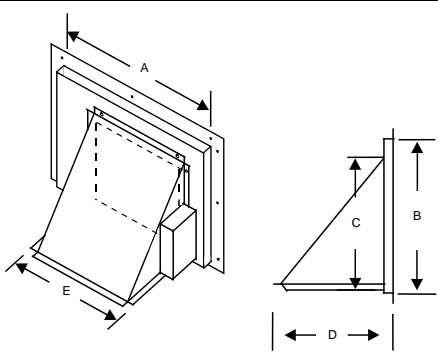
**Note:** The drawings on this page are prepared by the manufacturer in order to provide detail regarding job layout only. These drawings are not intended to be used as a basis to construct, build or modify the items depicted in the drawings. The manufacturer is not responsible for the unauthorized use of these drawings and expressly disclaims any liability for damages resulting from such unauthorized use.

## Optional Equipment – Outside Air Damper

**Table 15. BAYOSAH001 and 002A**

	Manual Fresh Air Model	Unit Application Models	A	B	C	D
	BAYOSAH001A	4024 – 4036	22-7/16"	20-11/16"	12-3/8"	9-3/16"
BAYOSAH002A	4042 – 4060	25-3/16"	20-11/16"	12-3/8"	9-3/16"	

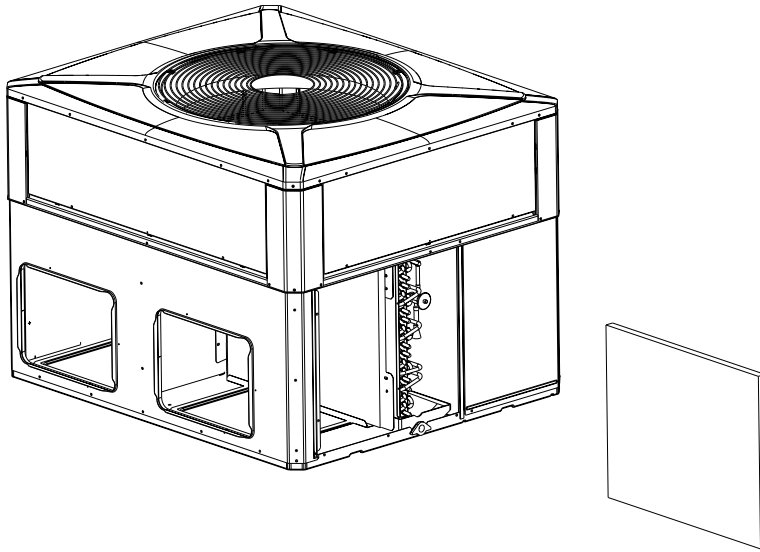
**Table 16. BAYDMPR101 and 102A, 25% Motorized Outside Air Damper (Mounts Over Horizontal Return Air Opening)**

	Manual Fresh Air Model	Unit Application Models	A	B	C	D	E
	BAYDM-PR101A	4024 – 4036	15-13/16"	11-13/16"	10-1/4"	11-1/2"	12-1/4"
BAYDM-PR102A	4042 – 4060	18-3/16"	15-1/8"	10-1/4"	11-1/2"	12-1/4"	

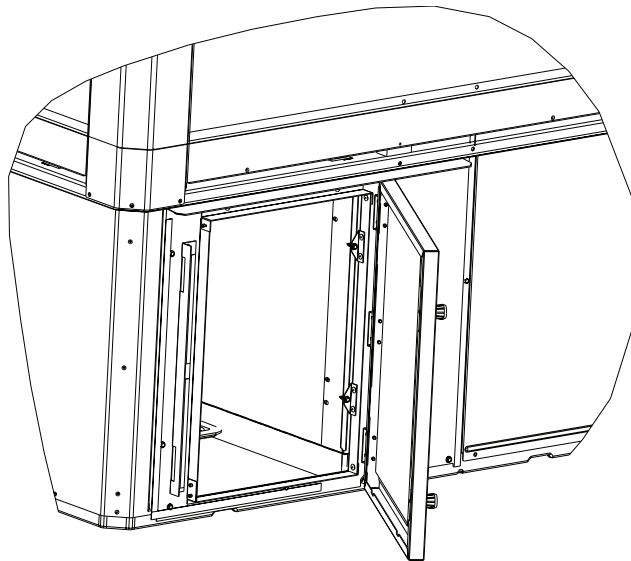
**Note:** The drawings on this page are prepared by the manufacturer in order to provide detail regarding job layout only. These drawings are not intended to be used as a basis to construct, build or modify the items depicted in the drawings. The manufacturer is not responsible for the unauthorized use of these drawings and expressly disclaims any liability for damages resulting from such unauthorized use.

## Optional Equipment — Filter Rack

**Figure 7. BAYFLTR101 Filter Rack (4024–4036)  
BAYFLTR201 (4042–4060)  
(Mounts in Filter/Coil Section)**



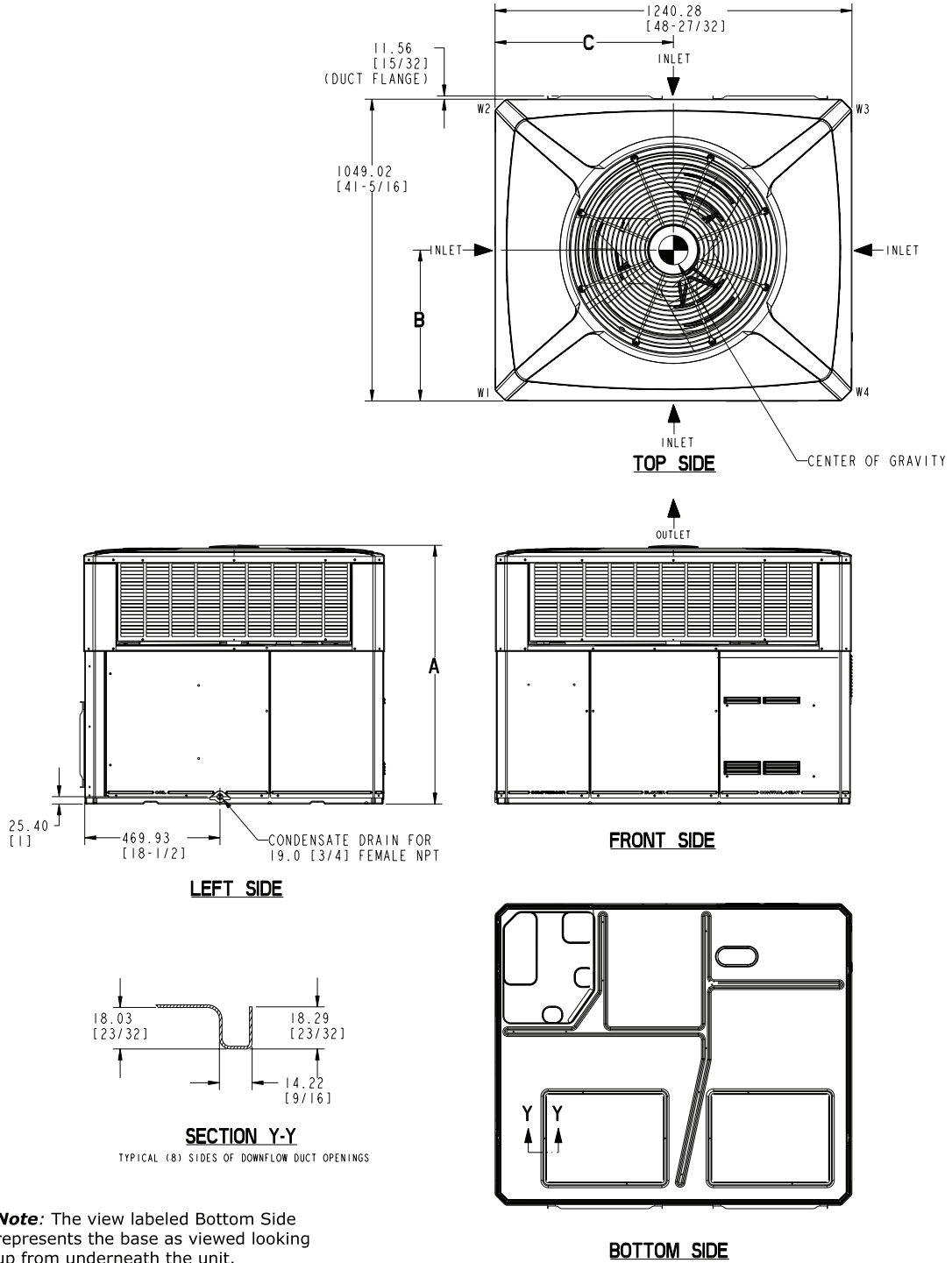
**Figure 8. BAYACCDOR1A Hinged Filter Access Door (4024–4036)  
BAYACCDOR2A (4042–4060)  
Replaces Filter/Coil Access Panel**



**Note:** The drawings on this page are prepared by the manufacturer in order to provide detail regarding job layout only. These drawings are not intended to be used as a basis to construct, build or modify the items depicted in the drawings. The manufacturer is not responsible for the unauthorized use of these drawings and expressly disclaims any liability for damages resulting from such unauthorized use.

# Outline Drawings

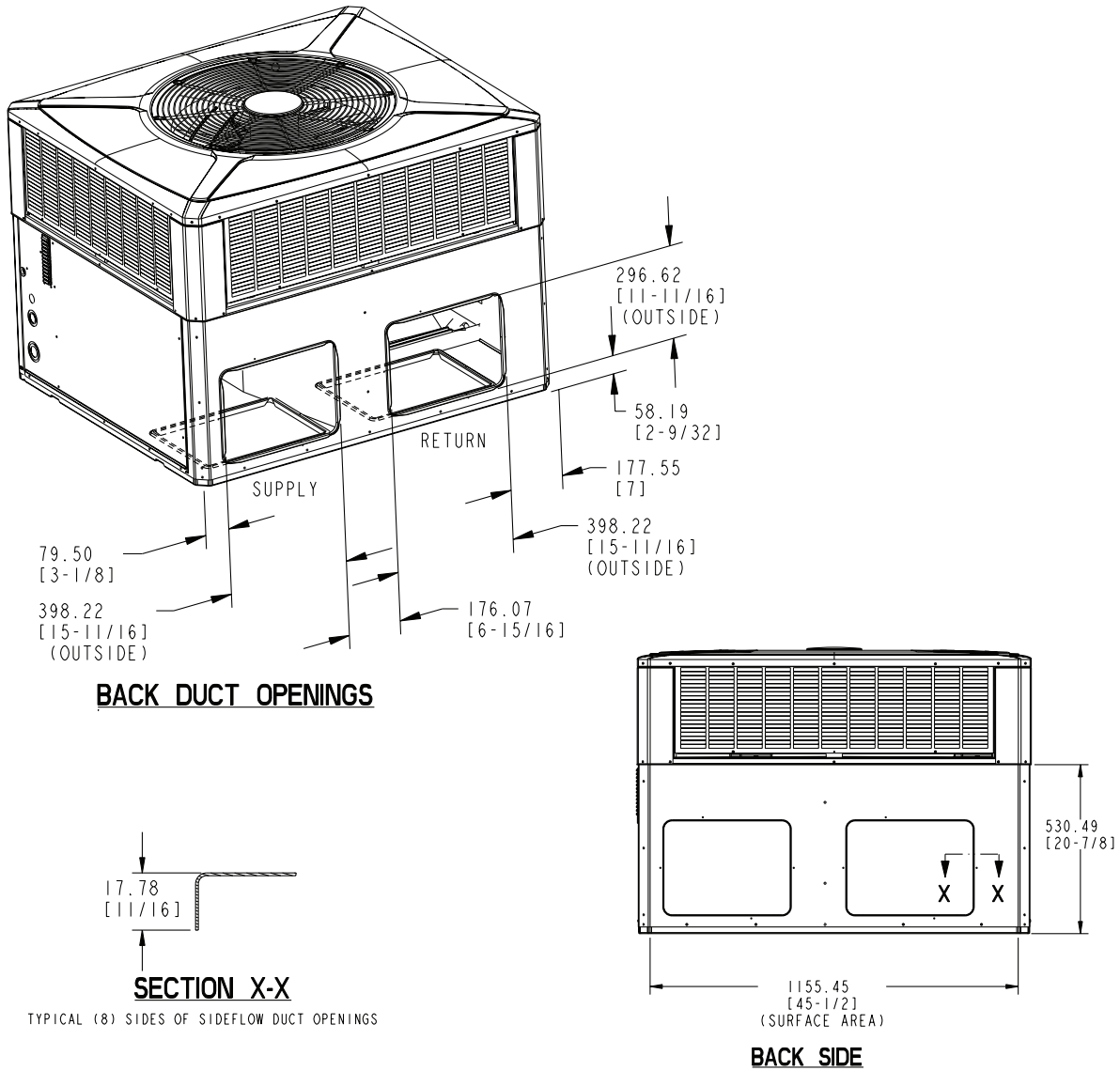
Figure 9. 2 — 3 TON MODELS



**Note:** The view labeled Bottom Side represents the base as viewed looking up from underneath the unit.

**Outline Drawings**

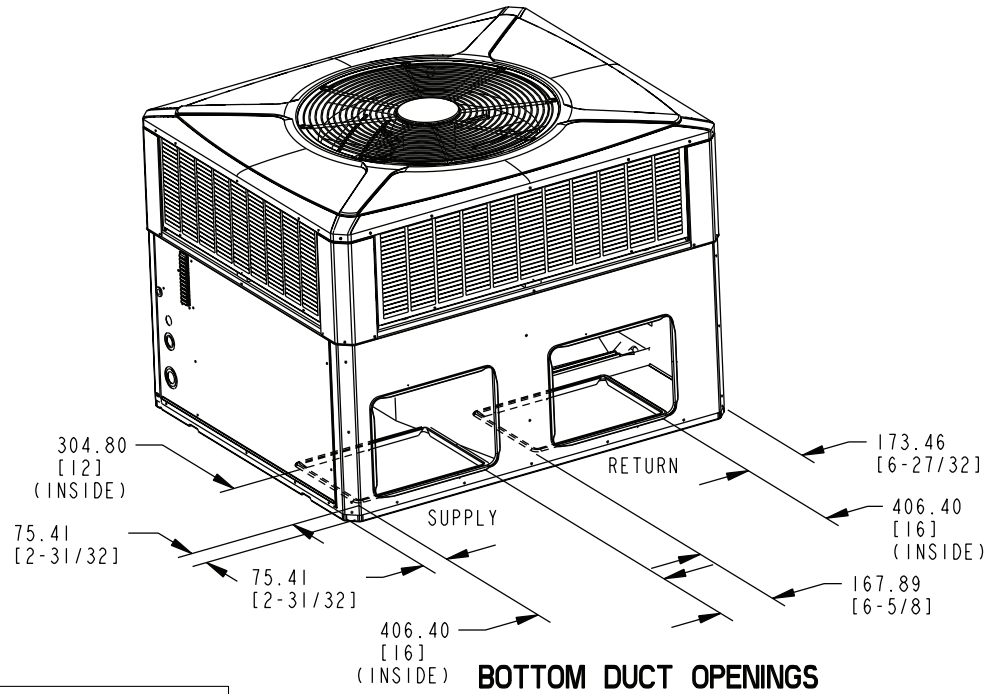
**Figure 10. 2 – 3 TON MODELS**



Model	Height MM/IN	APPROX. CORNER WEIGHT KG / LBS				SHIPPING WIGHT KG / LBS	TOTAL UNIT WEIGHT KG / LBS	CENTER OF GRAVITY MM/IN.	
		A	W1	W2	W3			W4	B
4TCC4024	898.53 [35 -3/8]	58.3 [129]	36.8 [81]	26.1 [58]	41.0 [90]	196.1 (432)	162.4 (358)	479.8 [18.9]	527.8 [20.8]
4TCC4030		61.3 [135]	38.7 [85]	27.5 [61]	43.1 [95]	204.8 (451)	171.1 (377)	406.5 [16.0]	594.1 [23.4]
4TCC4036	949.33 [37-3/8]	61.7 [136]	38.9 [86]	27.7 [61]	43.7 [96]	205.7 (453)	172.0 (379)	414.3 [16.3]	697.6 [27.5]
4WCC4024	898.53 [35-3/8]	52.9 [117]	33.3 [73]	24.1 [53]	38.3 [84]	182.3 (402)	148.6 (328)	430 [16.9]	565.3 [22.3]
4WCC4030	949.33 [37-3/8]	55.3 [122]	50.3 [110]	16.6 [37]	39.2 [86]	195.0 (430)	161.3 (355)	413.5 [16.3]	581 [22.9]
4WCC4036		59.6 [131]	37.3 [82]	26.6 [59]	41.7 [92]	199.0 (439)	165.3 (364)	430 [17.0]	535 [21.1]

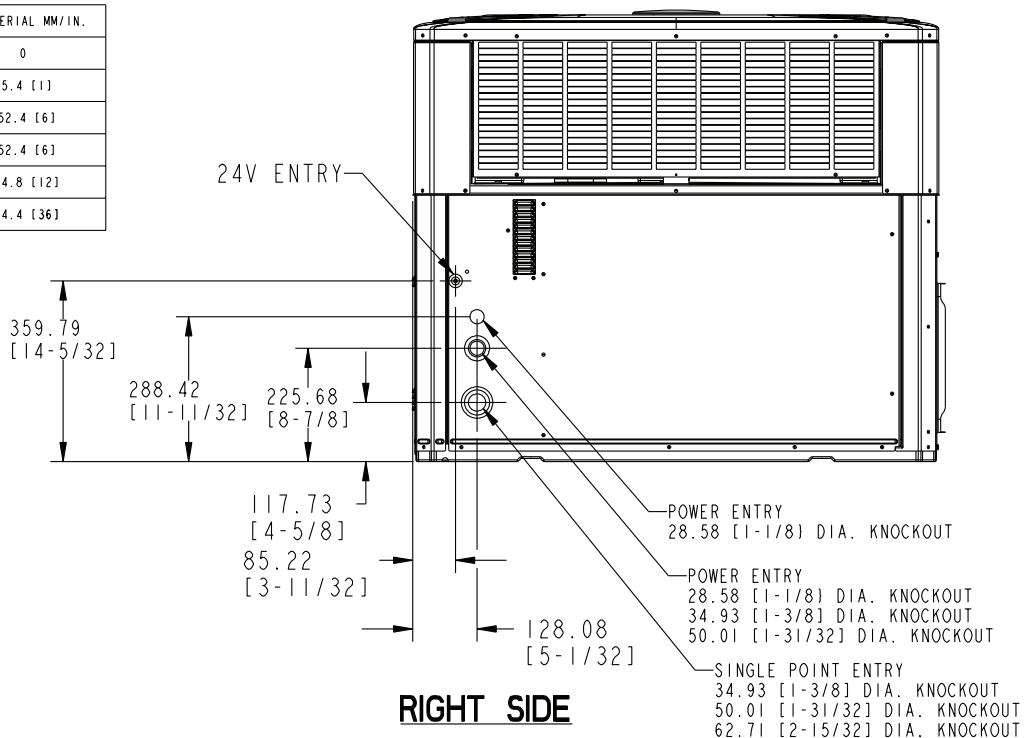


Figure 11. 2 – 3 TON MODELS



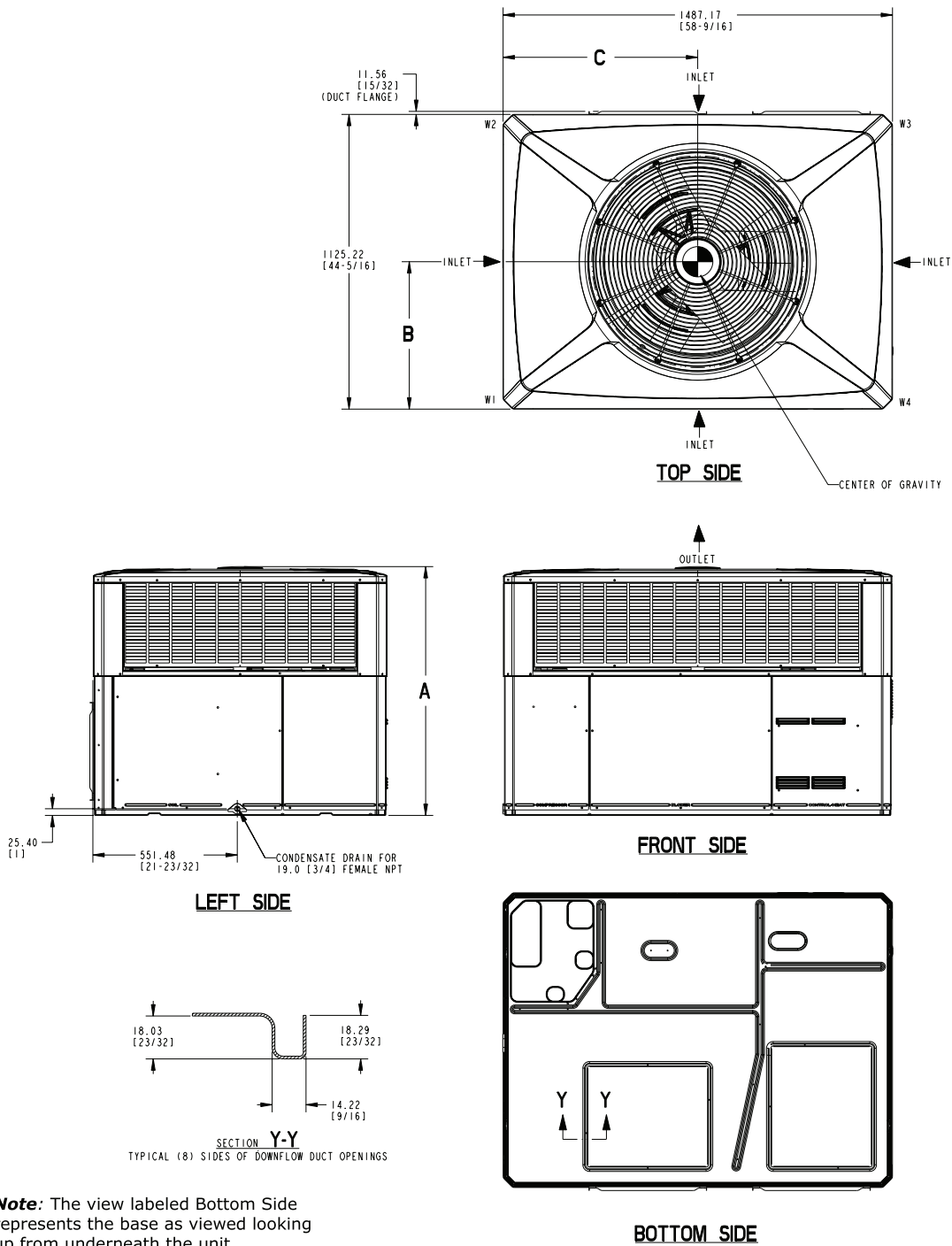
RECOMMENDED SERVICE CLEARANCE MM/IN.		
		WITH ECONOMIZER
BACK SIDE	304.8 [12]	762.0 [30]
LEFT SIDE	762.0 [30]	914.4 [36]
RIGHT SIDE	609.6 [24]	-
FRONT SIDE	1066.8 [42]	-

CLEARANCE TO COMBUSTIBLE MATERIAL MM/IN.	
BOTTOM	0
BACK SIDE	25.4 [1]
LEFT SIDE	152.4 [6]
RIGHT SIDE	152.4 [6]
FRONT SIDE	304.8 [12]
TOP	914.4 [36]



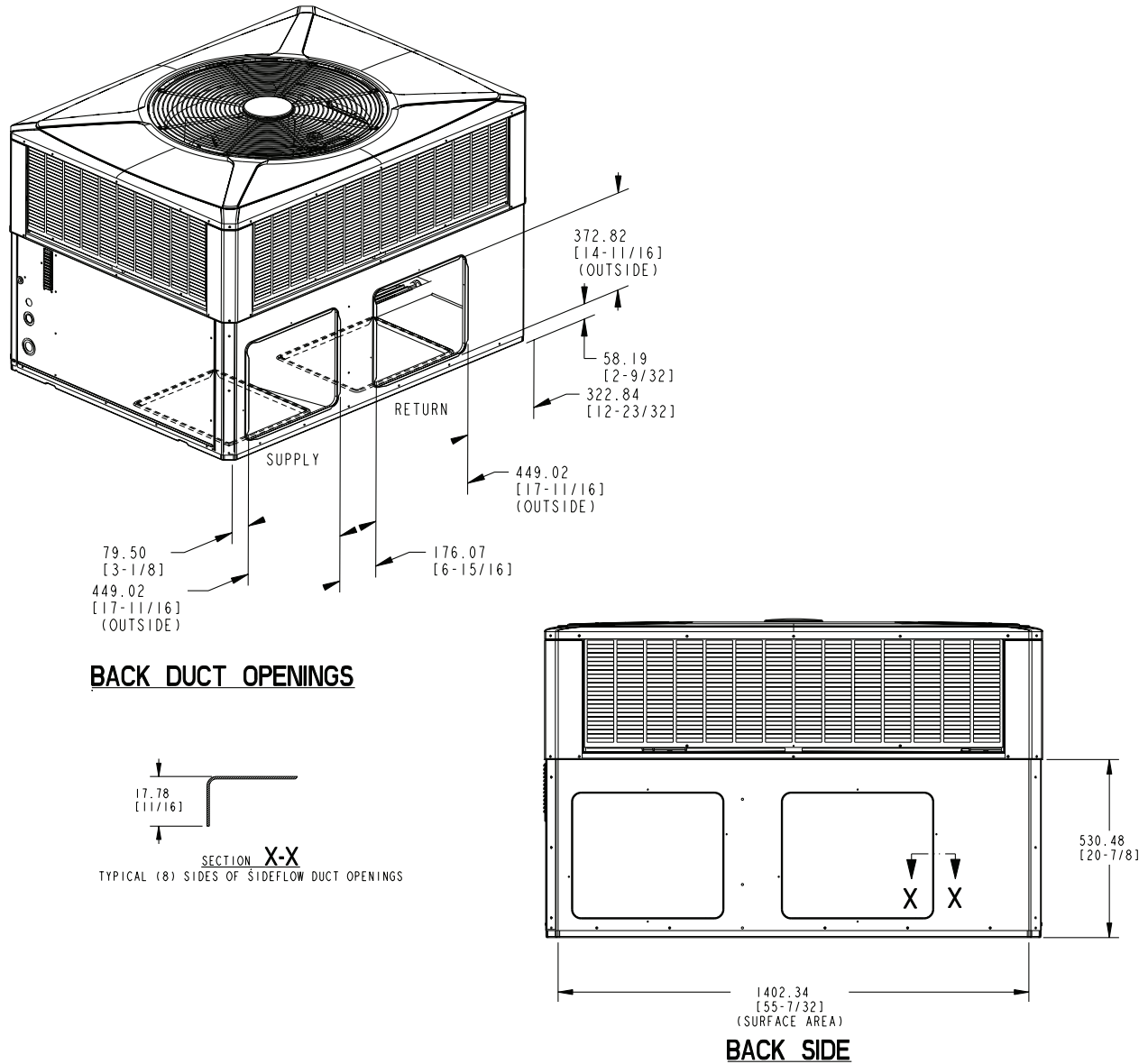
Outline Drawings

Figure 12. 3.5 – 5 TON MODELS



**Note:** The view labeled Bottom Side represents the base as viewed looking up from underneath the unit.

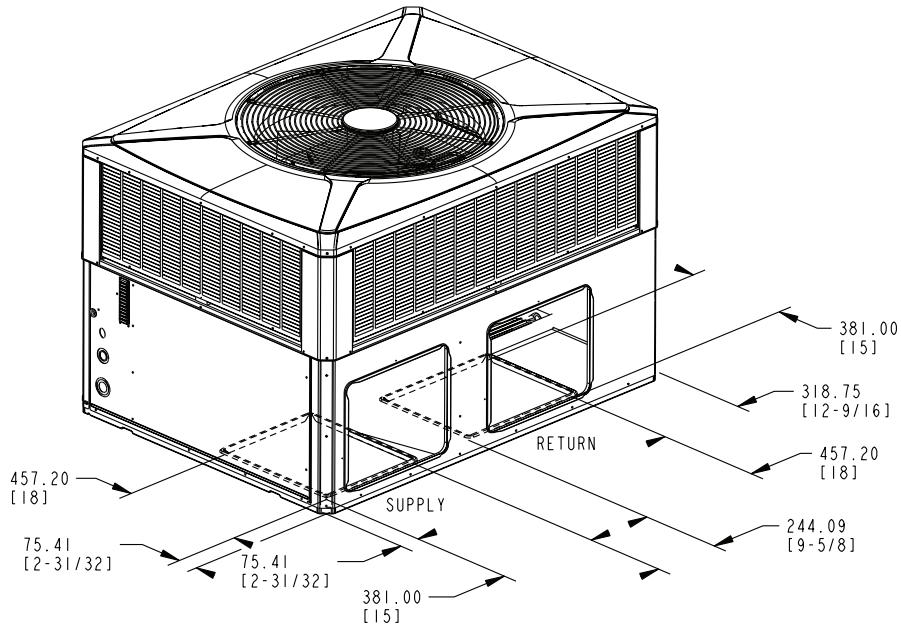
Figure 13. 3.5 – 5 TON MODELS



Model	Height MM/IN	APPROX. CORNER WEIGHT KG / LBS				SHIPPING WIGHT KG / LBS	TOTAL UNIT WEIGHT KG / LBS	CENTER OF GRAVITY MM/IN	
	A	W1	W2	W3	W4			B	C
4TCC4042	898.53 [35-3/8]	71.8 [158]	47.2 [104]	35.2 [78]	53.6 [118]	254.5 (561)	207.3 (457)	470.0 [18.5]	731.0 [28.8]
4TCC4048	1000.13 [39-3/8]	72.0 [159]	45.0 [99]	33.8 [75]	54.4 [120]	252.6 (557)	205.4 (453)	433.0 [17.0]	743.3 [29.3]
4TCC4060		78.0 [172]	46.3 [102]	34.9 [77]	59.0 [130]	265.8 (586)	218.6 (482)	414.0 [16.3]	635.0 [25.0]
4WCC4042		64.4 [142]	47.6 [105]	39.5 [87]	49.9 [110]	248.6 (547.9)	201.4 (444)	449.6 [17.7]	641.8 [25.3]
4WCC4048		68.9 [152]	40.8 [90]	30.8 [68]	52.2 [115]	240.0 (529)	192.8 (425)	414.0 [16.3]	635.0 [25.0]
4WCC4060		79.4 [175]	47.2 [104]	35.8 [79]	59.9 [132]	269.5 (594)	222.3 (490)	414.0 [16.3]	635.0 [25.0]

**Outline Drawings**

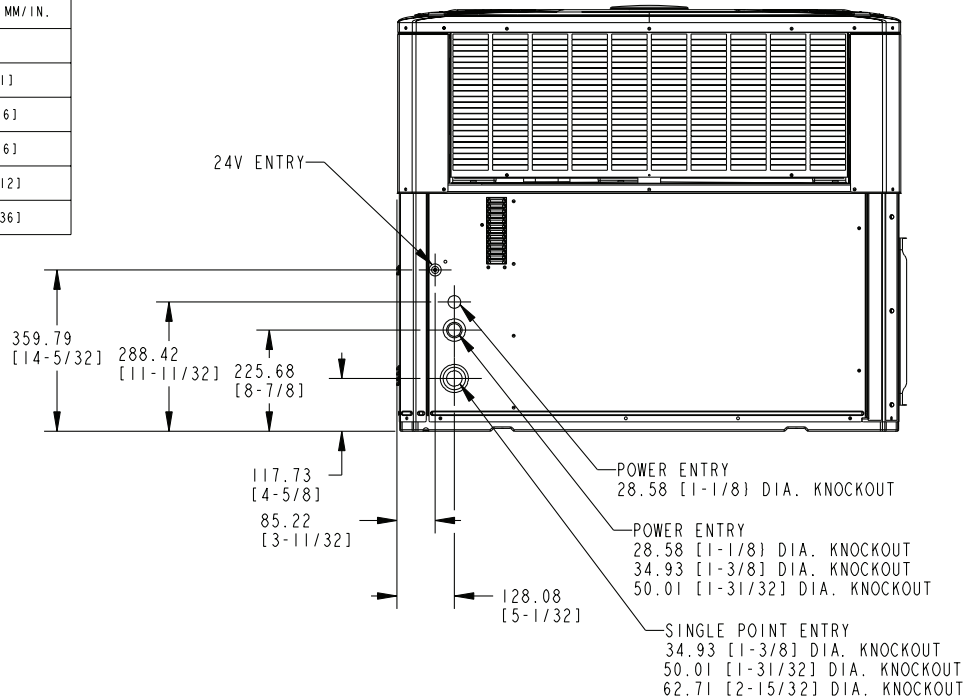
**Figure 14. 3.5 – 5 TON MODELS**



**BOTTOM DUCT OPENINGS**

RECOMMENDED SERVICE CLEARANCE MM/IN.		
		WITH ECONOMIZER
BACK SIDE	304.8 [12]	762.0 [30]
LEFT SIDE	914.4 [36]	1066.8 [42]
RIGHT SIDE	609.6 [24]	-
FRONT SIDE	762.0 [30]	-

CLEARANCE TO COMBUSTIBLE MATERIAL MM/IN.	
BOTTOM	0
BACK SIDE	25.4 [1]
LEFT SIDE	152.4 [6]
RIGHT SIDE	152.4 [6]
FRONT SIDE	304.8 [12]
TOP	914.4 [36]



**RIGHT SIDE**

# Mechanical Specifications

## General

The units shall be horizontal airflow as shipped and convertible to downflow. All units shall be factory assembled, piped, internally wired and fully charged with refrigerant. Units shall be certified to UL Standard 1995. All units shall be factory run tested to check cooling operation, fan and blower rotation and control or TXV sequence. Units shall be designed to operate at ambient temperatures between 115°F and 55°F in cooling as manufactured. Cooling performance shall be rated in accordance with AHRI standards.

## Unit Casing

All components shall be mounted in a weather-resistant steel cabinet with an enamel finish. Access panels shall be provided for unit controls and indoor coil and fans. Indoor air section compartment shall be completely insulated with fireproof, permanent, odorless fiber material. Knockouts shall be provided for utility and control connections. Drain connections shall be provided to accommodate indoor water runoff.

## Compressor

The compressor shall be hermetically sealed, high efficiency scroll compressors. Internal overcurrent and over temperature protection, internal pressure relief shall be standard. Other features include centrifugal oil pump, low vibration and noise.

## Refrigeration System

All units shall have refrigerant control. Service pressure tap ports and a refrigerant line filter shall be standard.

**Evaporator Coil (2–4 Ton Models)** All aluminum micro channel, extruded tubes, mechanically bonded to aluminum fins, and factory pressure and leak tested at 480 – 650 psig. All units have TXV to control refrigerant flow.

**Evaporator Coil (5 Ton Model)** Internally enhanced 3/8" OD seamless copper tubing mechanically bonded to aluminum fins, factory pressure and leak tested at 480 – 650 psig. All units have TXV to control refrigerant flow.

## Condenser Coil

The Spine Fin™ condenser coil shall be continuously wrapped, corrosion resistant all aluminum with minimum brazed joints. This coil is 3/8" OD seamless aluminum tubing glued to a continuous aluminum fin. Coils are lab tested to withstand 2,000 pounds of pressure per square inch. The outdoor coil provides low airflow resistance and efficient heat transfer. The coil is protected on all four sides by louvered panels.

## Indoor Air Fan

Constant Torque, forward-curved, centrifugal wheel in a Composite Vortica® Blower housing. Motor shall have thermal overload protection and permanently lubricated motor bearings. Motor/blower assembly isolated from unit with rubber mounts.

## Outdoor Fan

One direct-drive, statically and dynamically balanced propeller fan shall be used in a draw-through vertical discharge configuration. Permanently lubricated weather proof motor shall have built-in thermal overload protection.

## System Controls

System controls include condenser fan, evaporator fan and compressor contactors.

## Accessories Roof Curb

The roof curb shall be designed to mate with the unit and provide support and complete weathertight installation when properly installed. Adhesive back polyurethane sealing strips shall be provided to ensure an airtight seal between supply and return openings of the curb and unit. The roof curb design allows field fabricated ductwork to be connected directly to the curb. Curb ships knocked down for field assembly, and includes factory installed wood nailer strips.

## Mechanical Specifications

---

### **Electric Heaters**

Each heater assembly shall include power supply fusing if over 48 amps, automatic resetting limit switches and heat limiters for thermal protection. Heaters shall be provided with polarized plugs for quick connection to unit low voltage wiring. Electric heat modules shall be UL listed.

### **Single Source Power Entry**

This accessory when used with electric heat accessory shall allow single source power connection to unit and heater combination. Single source power entry kits shall have specific matching heater(s). Kit shall include high voltage terminal blocks, fuse blocks and fuses, cut-to-length interconnecting wiring, and junction box (if required) to provide power sources with fuse protection as required for both the unit and accessory heater. Kit components shall install within the heater cabinet in the heater access section. Single source branch power circuit shall be protected and wired in accordance with local codes.

### **Fully Modulating Economizer**

This accessory shall be field installed and be composed of the following items: 0–100 % fresh air damper, damper drive motor, fixed dry bulb enthalpy control, and low voltage pigtailed for electrical connections. Solid state enthalpy or differential enthalpy control is optional. Economizer operations shall be controlled by the preset position of the enthalpy control. A barometric relief damper shall be standard with the economizer and provide a pressure operated damper that shall be gravity closing and prohibit entrance of outside air on equipment "off" cycle. Economizer requires BAYRLAY004A relay kit to interface the economizer to the heat pump.

### **Manual Outside Air Dampers**

Rain hood and screen shall be field installed. Suitable for up to 25% outside air.

### **Start Kit**

Extra compressor starting capacity for single phase equipment.

### **Control Options**

#### **Standard Indoor Thermostats**

Two stage heating/cooling or one stage heating/cooling thermostats shall be available in either manual or automatic changeover.

#### **Programmable Electronic Night Setting Thermostat**

Programmable electronic thermostat shall provide heating setback and cooling setup with 7-day programming capability. 1H/1C or 2H/2C models available.





*American Standard*<sup>®</sup>  
HEATING & AIR CONDITIONING

American Standard optimizes the performance of homes and buildings around the world. A business of Ingersoll Rand, the leader in creating and sustaining safe, comfortable and energy efficient environments, American Standard offers a broad portfolio of advanced controls and HVAC systems, comprehensive building services, and parts. For more information, visit [www.americanstandardair.com](http://www.americanstandardair.com).

American Standard has a policy of continuous product and product data improvements and reserves the right to change design and specifications without notice.

©2014 American Standard Heating & Air Conditioning

12-1361-1F-EN 18 Dec 2015

Supersedes 12-1361-1E-EN (June 2015)

