

Model AD-1 Automatic Drain Valve Trim Component for Dry Pipe, Deluge, and Preaction Valves

General Description

The TYCO Model AD-1 Automatic Drain Valve is designed for use with TYCO Dry Pipe, Deluge, and Preaction Valves. Provided as a trim component for these valves, the Model AD-1 Automatic Drain Valve is used to automatically drain the normally dry alarm lines. In operation, the Model AD-1 Drain Valve is normally open to atmosphere to provide a visual indication of properly set water and/or air seats within the dry pipe, deluge, or preaction valve.

The Model AD-1 Automatic Drain Valve is a direct replacement for the Central Model AD, Gem Model F793, and Star Model S410 drain valves.

NOTICE

The Model AD-1 Automatic Drain Valve described herein must be installed and maintained in compliance with this document, and with the applicable standards of the NATIONAL FIRE PROTECTION ASSOCIATION (NFPA), in addition to the standards of any authorities having jurisdiction. Failure to do so may impair the integrity of this device.

The owner is responsible for maintaining their fire protection system and devices in proper operating condition. Contact the installing contractor or product manufacturer with any questions.

Technical Data

Approvals

The Model AD-1 Automatic Drain Valve forms a part of the overall approvals given in the applicable technical data sheets for the TYCO Dry Pipe, Deluge, or Preaction Valves.

Maximum Pressure

250 psi (17,2 bar)

Assembly

Body Bronze
Inlet connection Galvanized steel
Ball Brass or Stainless Steel

Operation

The Model AD-1 Automatic Drain Valve is normally open to atmosphere. In the open position, it maintains the alarm line trim of dry pipe, deluge, or preaction valves at 0 psig until the system operates. When the Model AD-1 Automatic Drain Valve is in the normal open position, this valve provides a visual indication that water and/or air seats within the dry pipe, deluge, or preaction valve are properly set. Leakage or discharge from the Model AD-1 Automatic Drain Valve provides an indication of a problem requiring correction within the dry pipe, preaction, or deluge valve.

Upon system operation and flow of water through the alarm trim to the alarm devices, the Model AD-1 Automatic Drain Valve automatically closes upon increasing flow between 2 to 10 GPM (8 to 38 LPM), which will then divert waterflow pressure to the alarm devices such as a pressure alarm switch or water motor alarm. When the Model AD-1 Automatic Drain Valve is closed and pressurized, a small leakage past the ball seat is normal.

After system operation and upon draining the system, the Model AD-1 Automatic Drain Valve automatically opens at a pressure between 0.5 to 2.0 psig (0,03 to 0,14 bar).

The plunger on the Model AD-1 Automatic Drain Valve can be used to manually check that the Model AD-1 Automatic Drain Valve is in its normally open position by pushing in on the plunger and assuring that the ball has not been inadvertently seated.

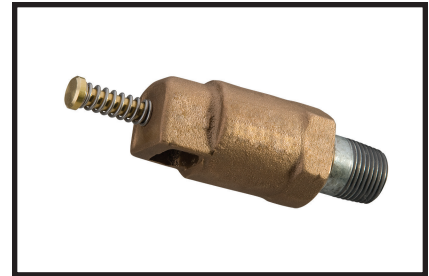

Installation

The Model AD-1 Automatic Drain Valve is provided as a trim component for TYCO Dry Pipe, Deluge, or Preaction Valves. The Model AD-1 Automatic Drain Valve must be installed in accordance with the specific instructions provided with TYCO Dry Pipe, Deluge, or Preaction Valve technical data sheets.

Care and Maintenance

The TYCO Model AD-1 Automatic Drain Valve must be inspected in accordance with instructions provided with the TYCO Dry Pipe, Deluge, or Preaction Valve technical data sheets, in addition to any specific requirements of the NFPA. Any impairment must be immediately corrected.

Before closing a fire protection system control valve for inspection or maintenance work on the fire protection system that it controls, obtain permission to shut down the effected fire protection system from the proper authorities and notify all personnel who may be affected by this action.

After placing a fire protection system in service, notify the proper authorities and advise those responsible for monitoring proprietary and/or central station alarms.

IMPORTANT

Refer to Technical Data Sheet TFP2300 for warnings pertaining to regulatory and health information.

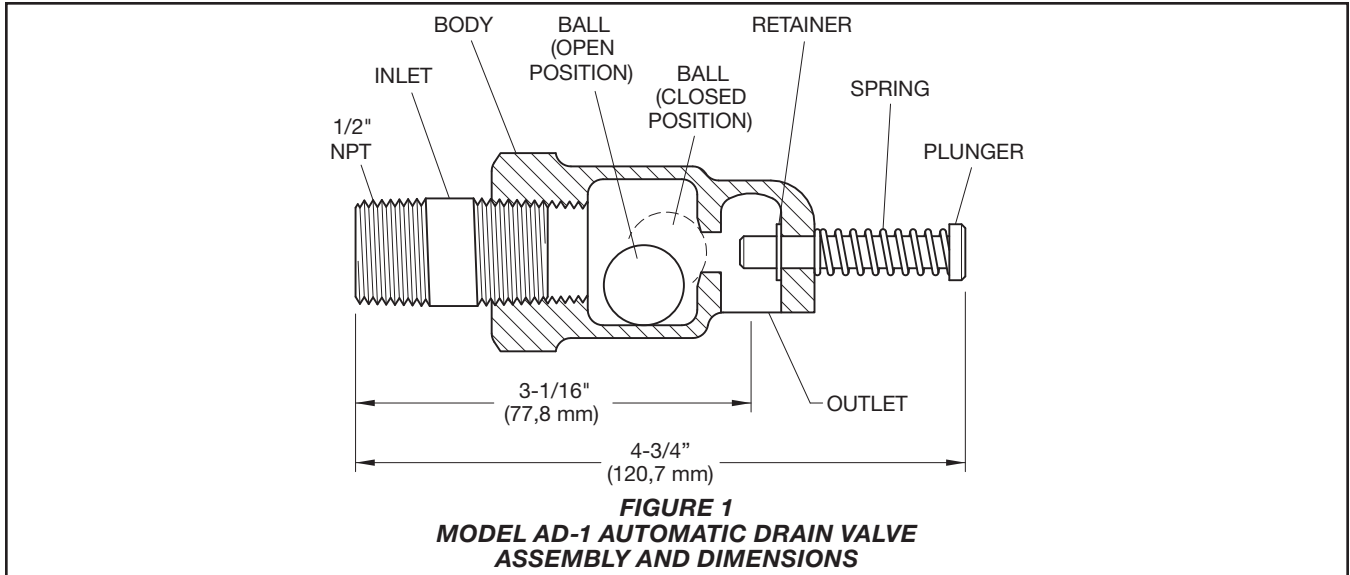

The owner is responsible for the inspection, testing, and maintenance of their fire protection system and devices in compliance with this document, as well as with the applicable standards of the NATIONAL FIRE PROTECTION ASSOCIATION (e.g., NFPA 25), in addition to the standards of any authority having jurisdiction. Contact the installing contractor or product manufacturer with any questions.

Automatic sprinkler systems are recommended to be inspected, tested, and maintained by a qualified Inspection Service in accordance with local requirements and/or national codes and standards.

Limited Warranty

For warranty terms and conditions, visit www.tyco-fire.com.

Ordering Information

The TYCO Model AD-1 Automatic Drain Valve is provided as a trim component for TYCO Dry Pipe, Deluge, or Preaction Valves. Contact your local distributor for availability.

Orders for replacement Model AD-1 Automatic Drain Valves must include a full description and Part Number (P/N).

Black Steel Inlet

Specify: Model AD-1 Automatic Drain Valve with black steel inlet,
P/N 52-793-1-004

Galvanized Steel Inlet

Specify: Model AD-1 Automatic Drain Valve with galvanized steel inlet,
P/N 52-793-2-004

Brass Inlet

Specify: Model AD-1 Automatic Drain Valve with brass inlet,
P/N 52-793-3-004