

JCM Service Saddles

JCM Service Saddles provide a quick, dependable means of tapping pipe for branch connections of 1/2" through 2-1/2". Use of economical JCM Service Saddles eliminate problems common to direct taps, such as leaking threads or split pipe, and reinforces the critical connection.

JCM Service Saddles are designed for maximum safety and performance. The wrap around design, wide skirt and wide straps support and reinforce the pipe while providing excellent stability to the saddle. The heavy duty design of these saddles provides strength and mass for long term service.

High pressure performance is assured by the broad, pressure activated gasket. Permanently set in a retaining cavity, the contoured gasket produces a positive initial seal which increases with increase in line pressure.

The JCM 402, 404, 406, 408 saddles, with their wide bodies and large sealed outlet areas, provide an excellent means of repairing holes, pin holes and leaking 3/4" and 1" direct taps.

DESIGNED FOR SAFETY AND PERFORMANCE

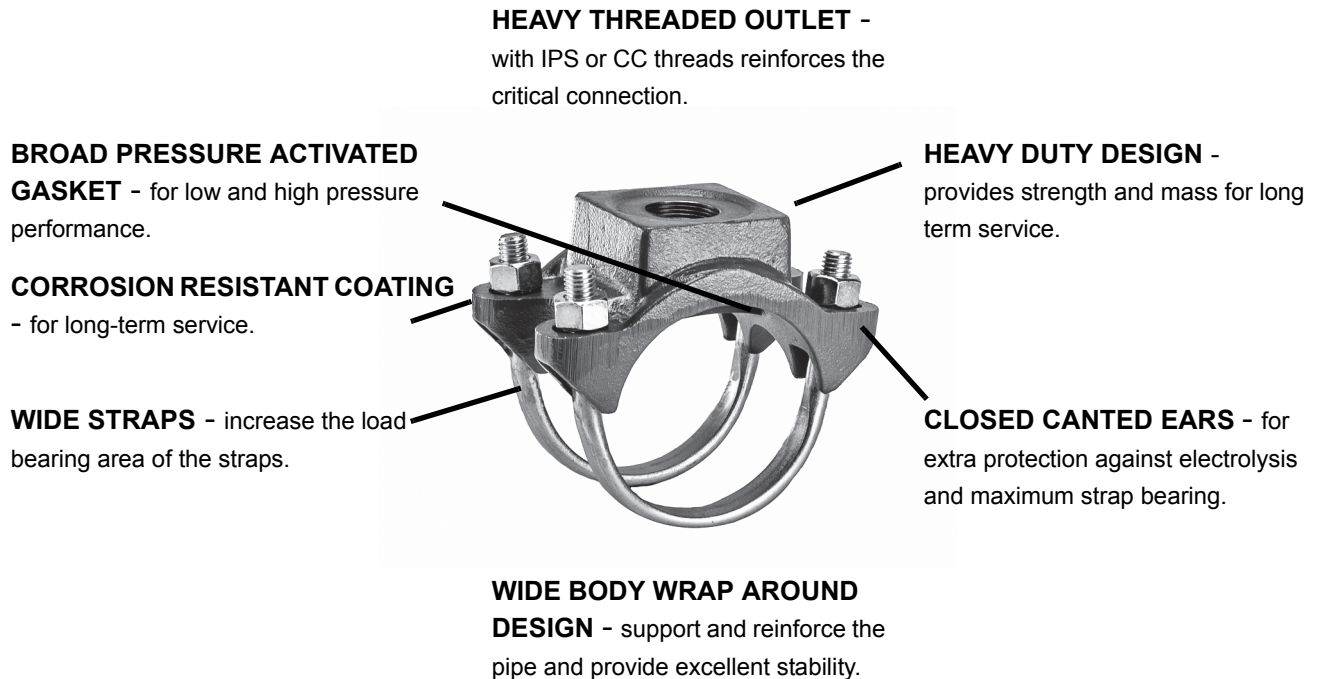

MATERIAL SPECIFICATIONS - JCM SERVICE SADDLES

Body: Ductile Iron ASTM A536

Straps: **Models 401, 402, 407, 408** - Electro Galvanized Steel

Models 403, 404, 405, 406 - Bands, Bolts, Nuts and Washers are 18-8 Type 304 Stainless Steel.

Gasket: Nitrile Butadiene Rubber (NBR, Buna-N) per ASTM D2000. Molded virgin rubber with a pressure activated hydromechanical design. Gasket is bonded into a cavity for internal and external retention. Gasket temperature range -40°F to 212°F (-40°C - 100°C) Gasket suitable for water, salt solutions, mild acids, bases, and sewage. Optional EPDM gasket available.

Finish: **Models 401, 402, 403, 404** - Standard Shop Coat Primer: Heavy coat of corrosion resistant metal primer.

Models 405, 406, 407, 408 - Fusion Plastic Coating: fusion bonded, high density blue plastic coating, 12 mils minimum thickness with a dielectric strength of over 12,000 volts.

JCM Coated Service Saddles - Double Straps
JCM 406 Coated Saddle - Double Stainless Steel Straps
JCM 408 Coated Saddle - Electro Galvanized Straps

The JCM 406 and 408 utilize the heavy duty double strap saddle body with a fusion applied, heavy resilient plastic coating. The JCM 406 is furnished with two stainless steel straps. The model 408 is furnished with two electro galvanized steel straps.



NOM. PIPE SIZE (IN.)	PIPE O.D. RANGE (IN.)	WT. EA. LBS.	CTN. QTY.	JCM 406 SERVICE SADDLE	JCM 408 SERVICE SADDLE
				BASE CATALOG NUMBER X ADD TAP CODE	BASE CATALOG NUMBER X ADD TAP CODE
2	2.35 - 2.63	4	6	*406-0238 X --	*408-0238 X --
2-1/2	2.70 - 3.13	5	6	*406-0288 X --	*408-0288 X --
3	3.25 - 3.50	7	6	**406-0350 X --	**408-0350 X --
3 - 4	3.80 - 4.13	7	6	**406-0413 X --	**408-0413 X --
4	4.25 - 4.50	10	4	406-0450 X --	408-0450 X --
4	4.50 - 4.80	10	4	406-0480 X --	408-0480 X --
4	4.74 - 5.45	10	4	406-0545 X --	408-0545 X --
5	5.50 - 5.56	10	4	406-0556 X --	408-0556 X --
6	6.50 - 6.63	10	4	406-0663 X --	408-0663 X --
6	6.63 - 6.90	10	4	406-0690 X --	408-0690 X --
6	6.84 - 7.60	10	4	406-0745 X --	408-0745 X --
8	8.50 - 8.63	12	4	406-0863 X --	408-0863 X --
8	8.63 - 9.05	13	4	406-0905 X --	408-0905 X --
8	8.99 - 9.79	13	4	406-0963 X --	408-0963 X --
10	10.60 - 10.75	14	3	406-1075 X --	408-1075 X --
10	10.75 - 11.10	14	3	406-1110 X --	408-1110 X --
10	11.10 - 11.40	14	3	406-1140 X --	408-1140 X --
10	11.00 - 12.25	14	3	406-1225 X --	408-1225 X --
12	12.75 - 13.20	16	3	406-1320 X --	408-1320 X --
12	12.75 - 13.50	16	3	406-1350 X --	408-1350 X --
12	13.10 - 14.38	16	2	406-1426 X --	408-1426 X --
12 - 14	14.00 - 15.20	15	1	406-1520 X --	408-1520 X --
14	C-905 15.30	15	1	406-1530 X --	408-1530 X --
14 - 16	15.20 - 16.60	15	1	406-1660 X --	408-1660 X --
16	C-905 17.40	16	1	406-1740 X --	408-1740 X --
16 - 18	17.30 - 18.88	16	1	406-1888 X --	408-1888 X --
18	C-905 19.50	18	1	406-1950 X --	408-1950 X --
18 - 20	19.00 - 20.50	18	1	406-2050 X --	408-2050 X --
18 - 20	20.50 - 21.50	18	1	406-2125 X --	408-2125 X --
20	C-905 21.60	20	1	406-2160 X --	408-2160 X --
20	21.35 - 22.60	20	1	406-2260 X --	408-2260 X --
20	22.50 - 23.70	20	1	406-2370 X --	408-2370 X --
24	23.75 - 25.25	20	1	406-2525 X --	408-2525 X --
24	C-905 25.80	20	1	406-2580 X --	408-2580 X --
24	25.50 - 26.50	20	1	406-2650 X --	408-2650 X --

OUTLET SIZES	TAP CODES IP	TAP CODES CC
1/2"	04	--
3/4"	06	07
1"	08	09
1-1/4"	10	11
1-1/2"	12	13
2"	14	15
2-1/2"	16	--

*Outlets Not available in 1-1/4", 1-1/2", 2" or 2-1/2"

**Outlets Not available in 2" CC or 2-1/2" IP

HOW TO ORDER

1. Determine O.D. of pipe, outlet size and thread type.
2. Select desired saddle type and tap order code.
3. Look under saddle listing to determine order number. Add tap code after base catalog number.

Example: For 6" C.I. Pipe with O.D. of 6.90 with 1" IP thread, order: 406-0745 x 08IP.

For electro galvanized straps, order: 408-0745 x08IP