

5131-123 -
 PATT. No.
 CORE No.

PART NO.	MODEL	SIZE	A	B	C	D	E
5131-123	76110	3/4	4.54	.75	2.40	3/4	3/4
5131-070	76110	1 X 3/4 X 1	4.86	.75	2.40	1	1
5131-124	76110	1	5.48	1.00	2.65	1	1
5139-147	76110	1 1/4 X 1 X 1	5.75	1.00	2.65	1 1/4	1
5139-146	76110	1 1/4 X 1 X 1 1/4	6.34	1.00	2.65	1 1/4	1 1/4
5129-159	76110	1 1/2	6.84	1.50	3.40	1 1/2	1 1/2
5129-160	76110	2	8.77	2.00	3.67	2	2

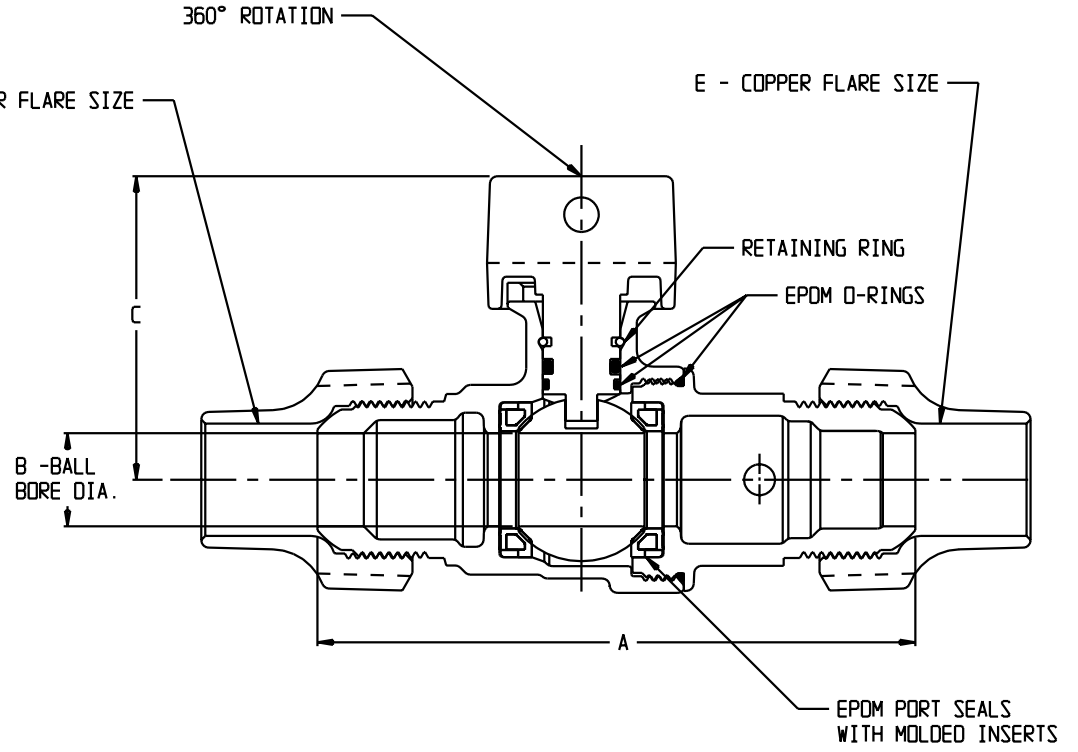

WETTED PARTS: C89833 COPPER ALLOY
 NON WETTED PARTS: C83600 COPPER ALLOY

A. Y. McDONALD CONSIDERS THE INFORMATION ON THIS ASSEMBLY DRAWING CORRECT WHEN PUBLISHED. ITEM AND OPTION AVAILABILITY INCLUDING SPECIFICATIONS, ARE SUBJECT TO CHANGE WITHOUT NOTICE. PLEASE VERIFY THAT PRODUCT INFORMATION IS CURRENT.

MATERIAL SPECIFICATIONS	
UNLESS OTHERWISE SPECIFIED - TOLERANCES, ETC.	
CASTINGS: +/- .025	
2 PLACE DECIMALS (.00) +/- .015	
3 PLACE DECIMALS (.000) +/- .005	
FINISH 125 max.	RADII: DRAFT:
CONCENTRICITY T.I.R. max.	DIMENSIONS IN INCHES

5131-123	09-239	---	RELEASED TO SALES ASSY DIRECTORY	DRAWN	CHECKED
				DJC	
				10-29-09	
				SCALE	APPROVED
	C.O. No.	SYM.	REVISIONS		
	This print is the property of A.Y. McDONALD MFG. CO., Dubuque, Iowa and is loaned subject to return upon demand. It is issued with the expressed agreement that it will not be issued directly or indirectly in any way detrimental to our interests. The acceptance of this drawing will be construed as an acceptance of the foregoing agreement.				
	A.Y. McDonald Mfg. Co. DUBUQUE, IOWA			5131-123	-

76110 BALL VALVE
 FLARE X FLARE
 - LESS CHECK