

INSTALLATION MANUAL

SINGLE PIECE NON-VARIABLE SPEED AIR HANDLERS

MODELS: AHP AND SHP SERIES



LIST OF SECTIONS

GENERAL	1	REQUIRED CONTROL SET-UP	8
SAFETY	1	LINE POWER CONNECTIONS	9
UNIT INSTALLATION	2	BLOWER SPEED CONNECTIONS	10
ELECTRIC HEATER INSTALLATION	6	UNIT DATA	10
LOW VOLTAGE CONTROL CONNECTIONS	7	MAINTENANCE	16

LIST OF FIGURES

Typical Installation	3	TXV	5
Return Duct Attachment & Component Location	3	Proper Bulb Location	6
Dimensions & Duct Connection Dimensions	4	Control Board	7
Condensate Deflector on Vertical Drain Pan	4	Line Power Connections	9
Condensate Deflector on Horizontal Drain Pan Edge	4	Blower Speed Connections	10
S-Clip Installation	5	Cooling Models with Electric Heat Wiring	16
Typical Horizontal Installation	5	Single-Stage Cooling Wiring	16

LIST OF TABLES

Dimensions	4	Electrical Data - (For Single Source Power Supply) - Copper Wire - 208/230-1-60	12
Low Voltage Connections	7	Electrical Data - (For Multi-Source Power Supply) - Copper Wire - 208/230-1-60	13
Fault Codes	8	Electrical Data - 208/230-3-60	13
Low Fan Control Inputs	8	Electrical Data - (For Single Source Power Supply) - Copper Wire - 208/230-3-60	14
Blower Delays	9	Electrical Data - (For Multi-Source Power Supply) - Copper Wire - 208/230-3-60	14
Heat Relays	9	Air Flow Data - 60 Hz Models - 208 Volt	15
Physical and Electrical Data	10	Air Flow Data - 60 Hz Models - 230 Volt	15
Conversion Table	10		
Electrical Data - Cooling Only (60 Hz)	11		
Electrical Data - 208/230-1-60	11		

SECTION I: GENERAL

The AHP single piece air handler provides the flexibility for installation in any upflow, downflow, or horizontal application. The SHP 48 & 60 models may be installed in upflow application only.

These versatile models may be used for cooling or heat pump operation with or without electric heat.

A BRAND LABEL (available from Distribution) may be applied to the center of the blower access panel.

The unit can be positioned for bottom return air in the upflow position, top return air in the downflow position, and right or left return in the horizontal position.

Top and side power wiring and control wiring, accessible screw terminals for control wiring, easy to install drain connections and electric heaters all combine to make the installation easy, and minimize installation cost.

SECTION II: SAFETY



This is a safety alert symbol. When you see this symbol on labels or in manuals, be alert to the potential for personal injury.

Understand and pay particular attention to the signal words **DANGER**, **WARNING**, or **CAUTION**.

DANGER indicates an **imminently** hazardous situation, which, if not avoided, **will result in death or serious injury**.

WARNING indicates a **potentially** hazardous situation, which, if not avoided, **could result in death or serious injury**.

CAUTION indicates a potentially hazardous situation, which, if not avoided **may result in minor or moderate injury**. It is also used to alert against unsafe practices and hazards involving only property damage.

WARNING

Improper installation may create a condition where the operation of the product could cause personal injury or property damage. Improper installation, adjustment, alteration, service or maintenance can cause injury or property damage. Refer to this manual for assistance or for additional information, consult a qualified contractor, installer or service agency.

CAUTION

This product must be installed in strict compliance with the installation instructions and any applicable local, state, and national codes including, but not limited to building, electrical, and mechanical codes.

WARNING

FIRE OR ELECTRICAL HAZARD

Failure to follow the safety warnings exactly could result in serious injury, death or property damage. A fire or electrical hazard may result causing property damage, personal injury or loss of life.

1. Install this air handler only in a location and position as specified in SECTION III of these instructions.
2. Always install the air handler to operate within the air handler's intended maximum outlet air temperature. Only connect the air handler to a duct system which has an external static pressure within the allowable range, as specified on the air handler rating plate.
3. When an air handler is installed so that supply ducts carry air circulated by the air handler to areas outside the space containing the air handler, the return air shall also be handled by duct(s) sealed to the air handler casing and terminating in the space to be cooled/heated.
4. The air handler is not to be used for temporary heating of buildings or structures under construction.
5. The size of the unit should be based on an acceptable heat loss or gain calculation for the structure. ACCA, Manual J or other approved methods may be used.

SAFETY REQUIREMENTS

1. This air handler should be installed in accordance with all national and local building/safety codes and requirements, local plumbing or wastewater codes, and other applicable codes.
2. Refer to the unit rating plate for the air handler model number, and then see the dimensions page of this instruction for supply air plenum dimensions in Figure 3. The plenum must be installed according to the instructions.
3. Provide clearances from combustible materials as listed under Clearances.
4. Provide clearances for servicing ensuring that service access is allowed for electric heaters and blower.
5. Failure to carefully read and follow all instructions in this manual can result in air handler malfunction, death, personal injury and/or property damage.
6. Check the rating plate and power supply to be sure that the electrical characteristics match.
7. Air handler shall be installed so the electrical components are protected from water.
8. Installing and servicing heating/cooling equipment can be hazardous due to the electrical components. Only trained and qualified personnel should install, repair, or service heating/cooling equipment. Untrained service personnel can perform basic maintenance functions such as cleaning and replacing the air filters. When working on heating/cooling equipment, observe precautions in the manuals and on the labels attached to the unit and other safety precautions that may apply.
9. These instructions cover minimum requirements and conform to existing national standards and safety codes. In some instances these instructions exceed certain local codes and ordinances, especially those who have not kept up with changing residential and non-HUD modular home construction practices. These instructions are required as a minimum for a safe installation.

INSPECTION

As soon as a unit is received, it should be inspected for possible damage during transit. If damage is evident, the extent of the damage should be noted on the carrier's freight bill. A separate request for inspection by the carrier's agent should be made in writing. Also, before installation the unit should be checked for screws or bolts, which may have loosened in transit. There are no shipping or spacer brackets which need to be removed.

Also check to be sure all accessories such as heater kits, suspension kits, and coils are available. Installation of these accessories or field conversion of the unit should be accomplished before setting the unit in place or connecting any wiring, electric heat, ducts or piping.

LIMITATIONS

These units must be wired and installed in accordance with all national and local safety codes. Voltage limits are as follows:

Air Handler Voltage	Voltage code	¹ Normal Operating Voltage Range
208/230-1-60	06	187-253
220/240-1-50	93	198-264

1. Rated in accordance with ARI Standard 110, utilization range "A". Airflow must be within the minimum and maximum limits approved for electric heat, evaporator coils and outdoor units.

Entering Air Temperature Limits			
Wet Bulb Temp. °F		Dry Bulb Temp. °F	
Min.	Max.	Min.	Max.
57	72	65	95

SECTION III: UNIT INSTALLATION

CLEARANCES

Clearances must be taken into consideration, and provided for as follows:

1. Refrigerant piping and connections - minimum 12" recommended.
2. Maintenance and servicing access - minimum 36" from front of unit recommended for blower motor / coil replacement.
3. Condensate drain lines routed to clear filter and panel access.
4. Filter removal - minimum 36" recommended.
5. The ductwork and plenum connected to this unit are designed for zero clearance to combustible materials.
6. A combustible floor base accessory is available for downflow applications of this unit, if required by local code.

LOCATION

Location is usually predetermined. Check with owner's or dealer's installation plans. If location has not been decided, consider the following in choosing a suitable location:

1. Select a location with adequate structural support, space for service access, clearance for air return and supply duct connections.
2. Use hanging brackets to wall mount this single piece air handler unit, is not recommended.
3. Normal operating sound levels may be objectionable if the air handler is placed directly over some rooms such as bedrooms, study, etc.
4. Select a location that will permit installation of condensate line to an open drain or outdoors allowing condensate to drain away from structure.

NOTE: The primary and secondary drain line must be trapped to allow proper drainage of condensate water. If the secondary drain line is not used, it must be capped.

The coil is provided with a secondary drain. It should be piped to a location that will give the occupant a visual warning that the primary drain is clogged. If the secondary drain is not used it must be capped.

5. When an evaporator coil is installed in an attic or above a finished ceiling, an auxiliary drain pan should be provided under the air handler as is specified by most local building codes.
6. Proper electrical supply must be available.
7. If unit is located in an area of high humidity (i.e. an unconditioned garage or attic), nuisance sweating of casing may occur. On these installations, unit duct connections and other openings should be properly sealed, and a wrap of 2" fiberglass insulation with vinyl vapor barrier should be used.

NOTE: In severe high humidity, high temperature indoor unit environments, an accessory insulation blanket is available to supplement the standard cabinet insulation. Insulate with UPG Kit: 1VJ0117 for B cabinets, 1VJ0121 for C cabinets or 1VJ0124 on 57" height or 1VJ0224 on 52" height D cabinets or seal completely with adequate fiberglass insulation using vapor barrier on the outside.

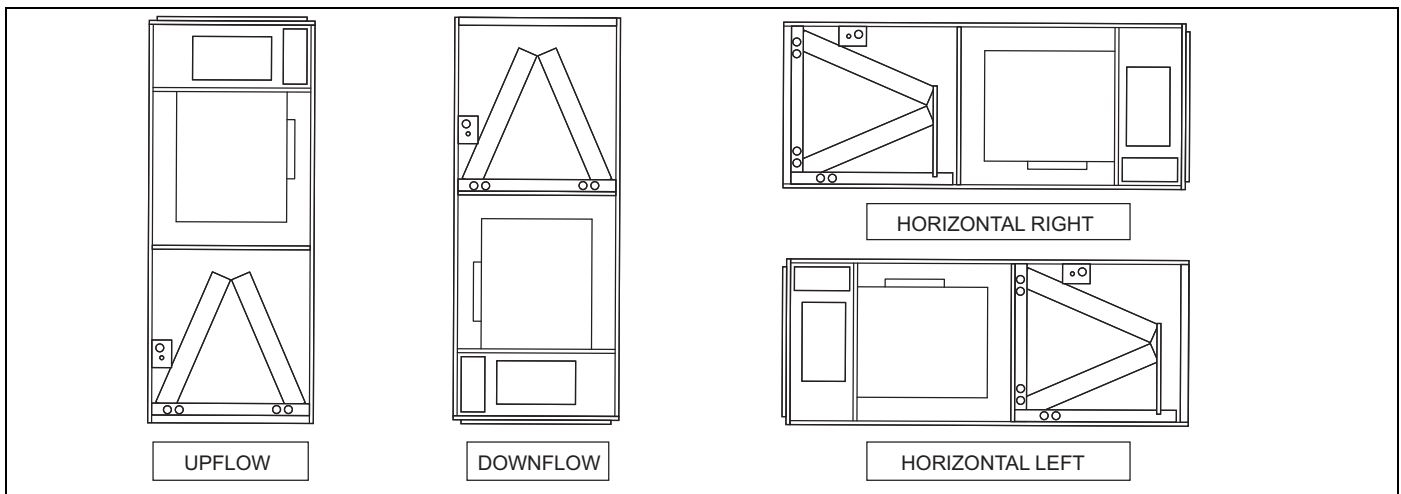

FIGURE 1: Typical Installation

DOWNFLOW AND HORIZONTAL CONVERSION (AHP ONLY)

These air handler units are supplied ready to be installed in a upflow and right hand horizontal position. If unit requires left hand positioning, the unit must have the coil assembly repositioned.

NOTE: The SHP models are for upflow installation only, and should not be installed in downflow/horizontal applications.

NOTE: For both horizontal applications, the condensate deflector should be positioned as shown in Figure 5.

1. Remove blower, coil, and filter access panels.

NOTE: Conversion must be made before brazing the refrigerant connections to the coil.

For downflow and horizontal left installations, follow steps 2 - 8.

2. Remove tubing connection panel.
3. Remove front drain pan, hold down bracket.
4. Slide coil assembly out of air handler.
5. Rotate cabinet 180° so blower outlet is facing down.
6. Re-install coil assembly on downflow bracket.
7. Re-attach front drain pan, hold down bracket.
8. Re-attach tubing connection panel.
9. For horizontal applications, rotate air handler 90° into desired orientation.
10. Re-position drain plugs as necessary based on air handler orientation.
11. Re-position and replace access panels.

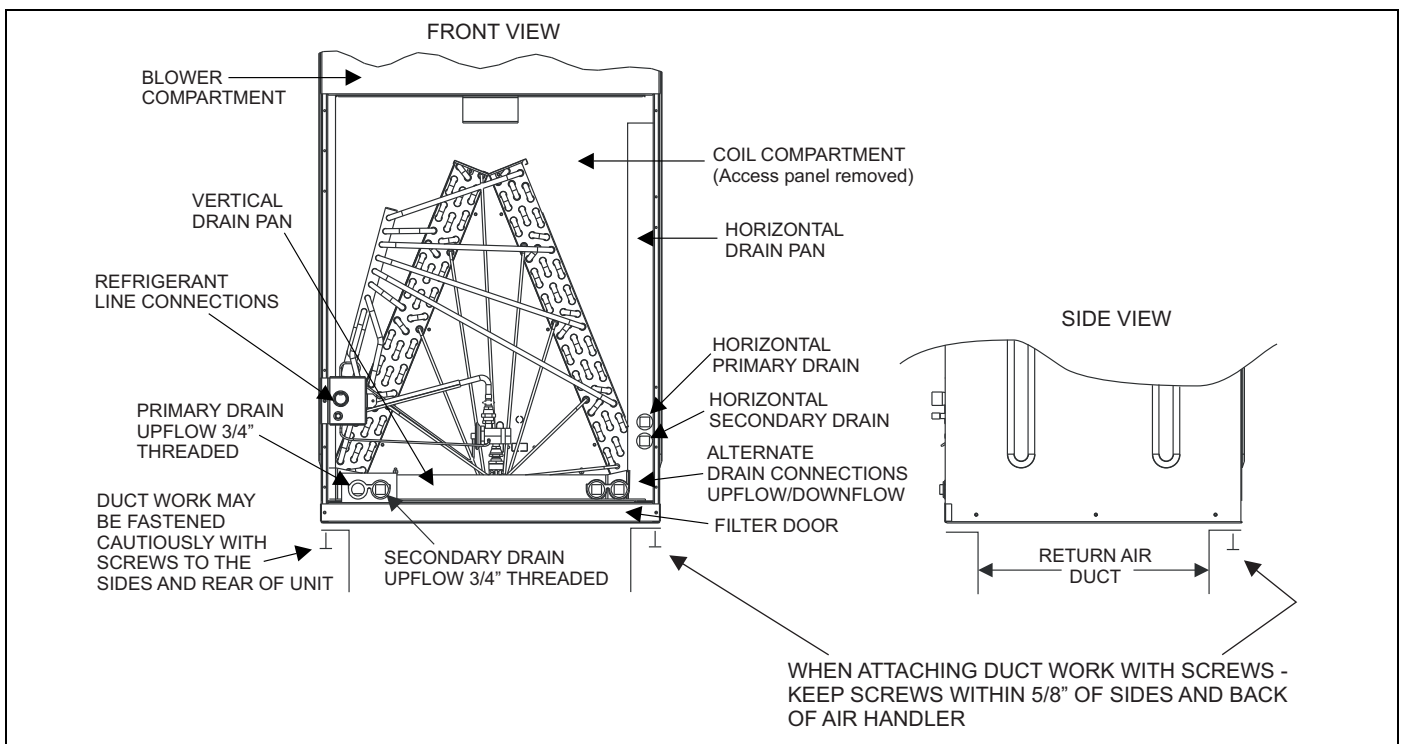

FIGURE 2: Return Duct Attachment & Component Location

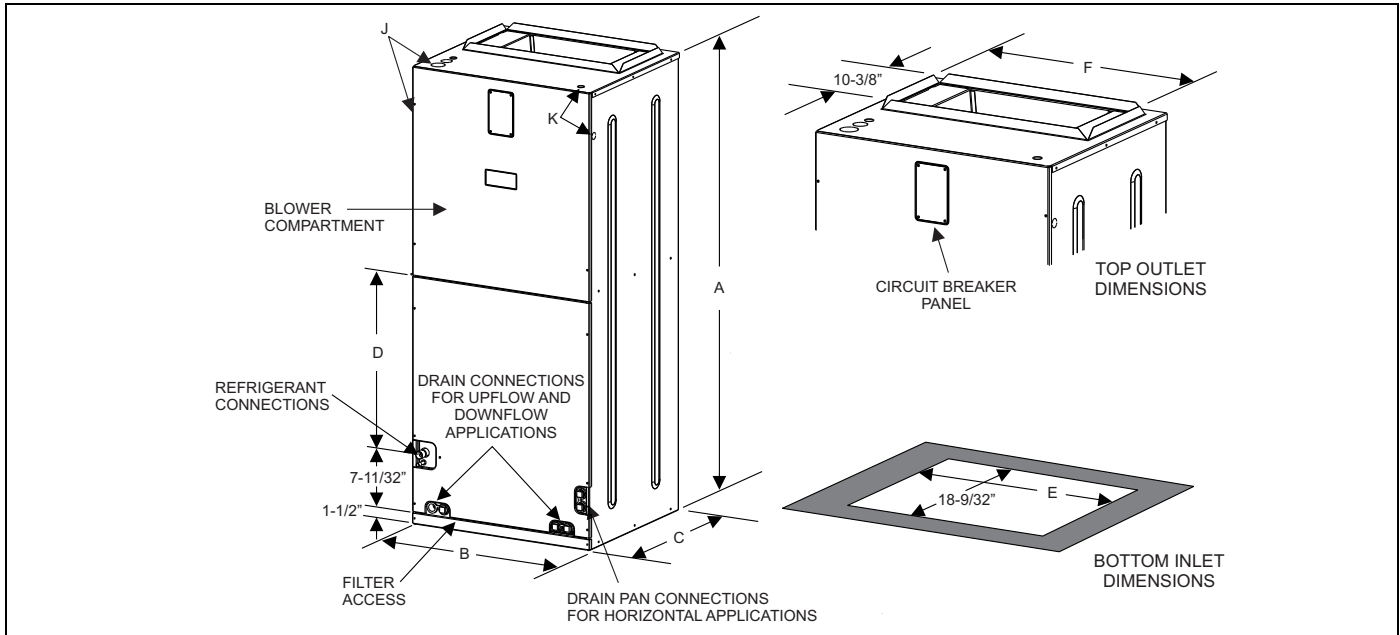

FIGURE 3: Dimensions & Duct Connection Dimensions

TABLE 1: Dimensions

Models AHP / SHP	Dimensions						Wiring Knockouts ¹		Refrigerant Connections Line Size	
	A	B	C	D	E	F	J	K	Liquid	Vapor
	Height	Width	Depth				Power	Control		
18B	46	17.5	22	12-3/8	13-29/32	14-19/32	7/8" (1/2") 1 3/8" (1") 1 23/32" (1 1/4")	7/8" (1/2")	3/8"	3/4"
24B	46	17.5		12-3/8	13-29/32	14-19/32				3/4"
30B	46	17.5		12-3/8	13-29/32	14-19/32				3/4"
36C	52	21		17-1/8	17-13/32	18-3/32				7/8"
42C	52	21		17-1/8	17-13/32	18-3/32				7/8"
48D	57	24.5		22-1/8	20-29/32	21-19/32				7/8"
SHP48D	52			17-1/8						7/8"
60D	57	24.5		22-1/8	20-29/32	21-19/32				7/8"
SHP60D	52		17-1/8	7/8"						

1. Actual size (Conduit size).

SUCTION FEEDER TUBE CONDENSATE DEFLECTOR UPFLOW OR DOWNFLOW

No action required. See Figure 4.

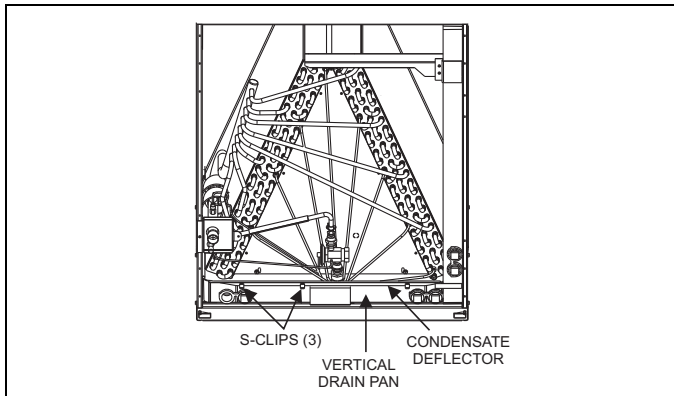

FIGURE 4: Condensate Deflector on Vertical Drain Pan

HORIZONTAL LEFT OR RIGHT

Use an appropriate tool to pry out water deflector with two or three s-clips from the vertical drain pan, see Figure 4. Relocate the deflector with s-clips on the Horizontal Drain Pan lined up to the coil support bracket. See Figure 5. This positions the deflector below the feeder tubes to channel the condensate to the drain pan.

NOTE: The condensate deflector should be installed in the s-clip section which is inside the drain pan edge. See Figure 6.

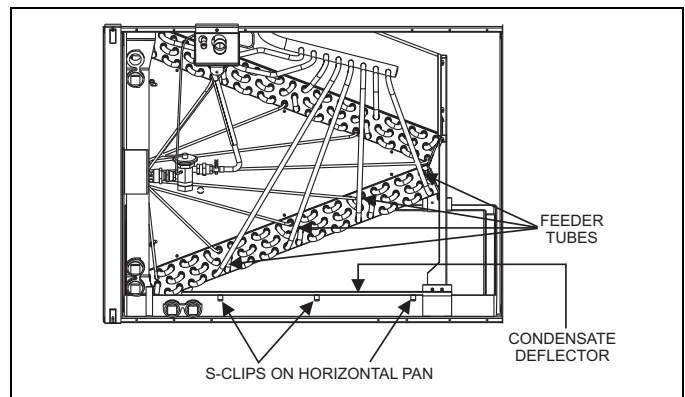

FIGURE 5: Condensate Deflector on Horizontal Drain Pan Edge

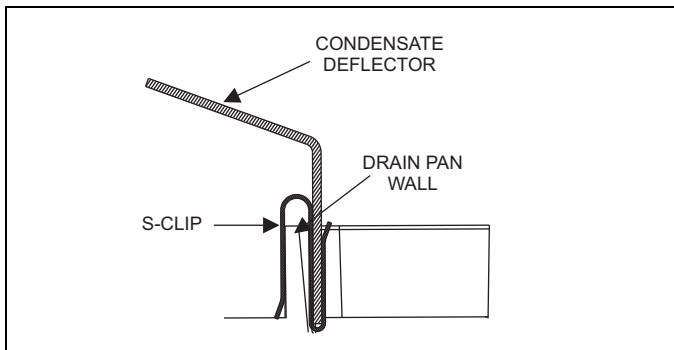

FIGURE 6: S-Clip Installation

DUCT CONNECTIONS

▲ **WARNING**

Use 1/2" screws to connect ductwork to bottom of unit. Longer screws will pierce the drain pan and cause leakage. If pilot holes are drilled, drill only through field duct and unit bottom flange.

Air supply and return may be handled in one of several ways best suited to the installation. See Figure 3 for dimensions for duct inlet and outlet connections.

The vast majority of problems encountered with combination heating and cooling systems can be linked to improperly designed or installed duct systems. It is therefore highly important to the success of an installation that the duct system be properly designed and installed.

Use flexible duct collars to minimize the transmission of vibration/noise into the conditioned space. If electric heat is used, non-flammable material must be used.

Where return air duct is short, or where sound may be a problem, sound absorbing glass fiber should be used inside the duct. Insulation of duct work is a must where it runs through an unheated space during the heating season or through an uncooled space during the cooling season. The use of a vapor barrier is recommended to prevent absorption of moisture from the surrounding air into the insulation.

The supply air duct should be properly sized by use of a transition to match unit opening. All ducts should be suspended using flexible hangers and never fastened directly to the structure. This unit is not designed for non-ducted (freeblow) applications. Size outlet plenum or transition to discharge opening sizes shown in Figure 3.

Duct work should be fabricated and installed in accordance with local and/or national codes. This includes the standards of the National Fire Protection Association for Installation of Air-Conditioning and Ventilating Systems, NFPA No. 90B.

AIR FILTERS

Air filters must be field supplied. A 1" filter access rack has been built into the unit. See Figure 3. Remove filter access cover shown. Install proper size filter. Standard 1" size permanent or throw away filter may be used, or, permanent washable filters are available using model numbers: 1PF0601, 602, 603BK. See Table 7 for filter size.

▲ **CAUTION**

Equipment should never be operated without filters.

HORIZONTAL SUSPENSION (AHP ONLY)

For suspension of these units in horizontal applications, it is recommended to use angle steel support brackets with threaded rods, supporting the units from the bottom, at the locations shown in Figure 7.

When an evaporator coil is installed in an attic or above a finished ceiling, an auxiliary drain pan should be provided under the air handler as is specified by most local building codes.

NOTE: SHP models may **not be** installed in downflow/horizontal applications.

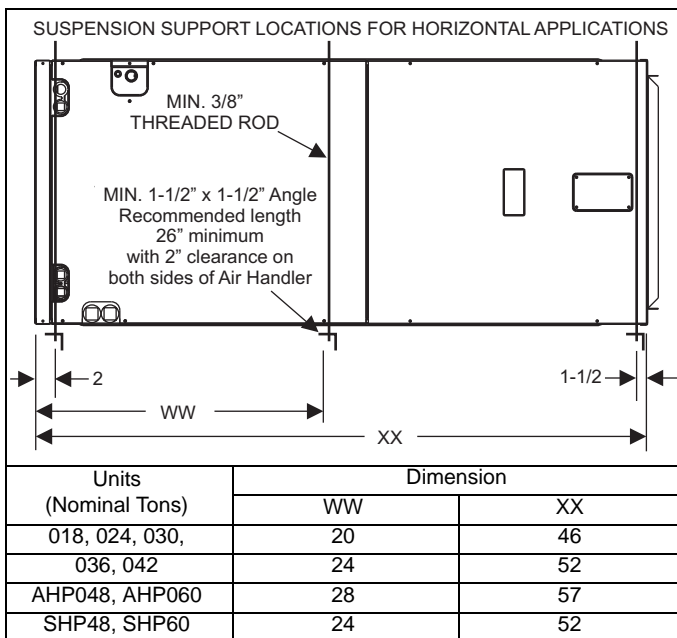

FIGURE 7: Typical Horizontal Installation

TXV METERING DEVICES

If the model number is of the following format: 2A, 2B, or 2C, the coil will have an R22 TXV metering device installed at the factory. The 4E, 4F, 4G, 4H, 4J, 4K and 4M will have the coil with R410A TXV metering device installed at the factory. R22 TXV can be replaced with a R410A TXV if required or vice versa.

If the model number is of the following model series: 3X, the coil will require a R22 or R410A TXV to be installed in the field. Refer to installation manual with TXV kit. It is recommended to install the TXV kit prior to brazing line sets.

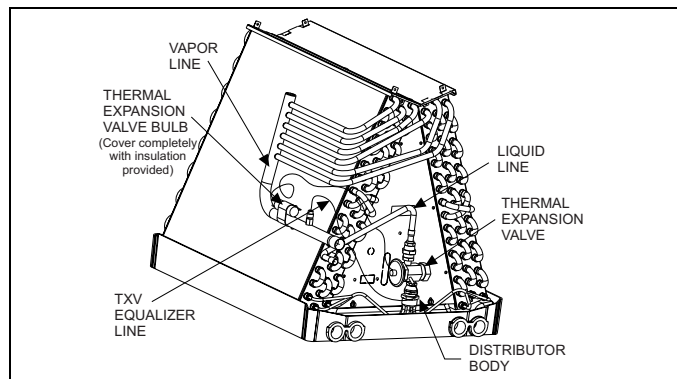

FIGURE 8: TXV

Please refer to Outdoor Unit Tech Guide to verify which TXV is installed in this coil and that this is a valid system match for the AC or HP unit installed.

The temperature sensing bulb is attached to the coil suction header line.

NOTE: For models that have factory installed TXV's, take caution not to apply high temperatures to the TXV assembly or equalizer line while brazing.

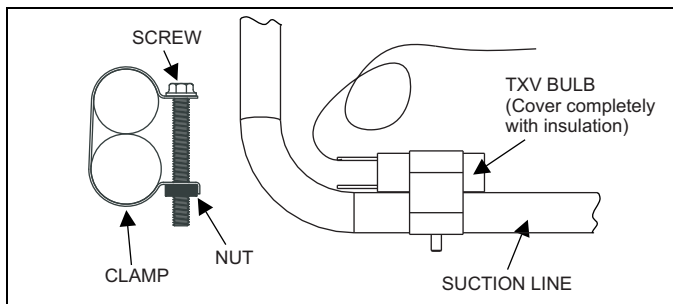

FIGURE 9: Proper Bulb Location

CAUTION

COIL UNDER PRESSURE.

Relieve pressure by removing plug from piping connection. Coil may have factory installed TXV or may require TXV to be added. See outdoor unit documentation for correct TXV to be used. Refer to coil nameplate for TXV identification for this unit.

NOTE: The coil should be open to the air for no more than 2 minutes to keep moisture and contaminants from entering the system. If the coil cannot be brazed into the refrigeration system in that time, the ends should be temporarily closed or plugged. For a short term delay, use masking tape over the ends of the copper tubing to close the tube to the air. For a longer term delay, use plugs or caps. There is no need to purge the coil if this procedure is followed.

REFRIGERANT LINE CONNECTION

CAUTION

Coil is under inert gas pressure. Relieve pressure from coil by removing rubber plug.

CAUTION

Dry nitrogen should always be supplied through the tubing while it is being brazed, because the temperature required is high enough to cause oxidation of the copper unless an inert atmosphere is provided. The flow of dry nitrogen should continue until the joint has cooled. Always use a pressure regulator and safety valve to insure that only low pressure dry nitrogen is introduced into the tubing. Only a small flow is necessary to displace air and prevent oxidation.

Connect lines as follows:

NOTE: Route the refrigerant lines to the coil in a manner that will not obstruct service access to the coil, air handling system, or filter.

1. Suction and liquid line connections are made outside the cabinet. Leave the tubing connection panel attached to the cabinet with the tubes protruding through it. Coil access panel should be removed for brazing. The lines are swaged to receive the field line set tubes.
2. Remove the heat shield from the Customer Packet, soak in water, and install over coil tubing to prevent overheating of cabinet.
3. Wrap a water soaked rag around the coil connection tubes inside the cabinet to avoid damaging the TXV bulb.
4. Remove grommets where tubes exit the cabinet to prevent burning them during brazing.
5. Purge refrigerant lines with dry nitrogen.
6. Braze the suction and liquid lines.
7. Remove the heat shield.
8. Re-attach the grommets to the lines carefully to prevent air leakage.

9. Attach the coil access panel to the cabinet.

Refer to Outdoor unit Installation Manual for evacuation, leak check and charging instructions.

Lines should be sound isolated by using appropriate hangers or strapping.

All evaporator coil connections are copper-to-copper and should be brazed with a phosphorous-copper alloy material such as Silfos-5 or equivalent. DO NOT use soft solder.

DRAIN CONNECTIONS

All drain lines should be trapped a minimum of three inches, should be pitched away from unit drain pan and should be no smaller than the coil drain connection.

CAUTION

Threaded drain connection should be hand-tightened, plus no more than 1/16 turn.

Route the drain line so that it does not interfere with accessibility to the coil, air handling system or filter and will not be exposed to freezing temperatures. See Figures 2 and 3 for drain connection locations.

CAUTION

When the coil is installed in an attic or above a finished ceiling, an auxiliary drain pan should be provided under the coil if specified by local building codes. When this exterior secondary drain pan is used that drain should be piped to a location that will give the occupant a visual warning that the primary drain is clogged.

Coils should be installed level or pitched slightly toward the drain end. Suggested pitch should not exceed 1/4 inch per foot of coil.

The coil is provided with a secondary drain that should be trapped and piped to a location that will give the occupant a visual warning that the primary drain is clogged. If the secondary drain is not used it must be capped.

The drain pan connections are designed to ASTM Standard D 2466 Schedule 40. Use 3/4" PVC or steel threaded pipe. Since the drains are not subject to any pressure it is not necessary to use Schedule 40 pipe for drain lines.

It is recommended that all drain connections be sealed with teflon tape or equivalent.

SECTION IV: ELECTRIC HEATER INSTALLATION

If the air handler requires electric heat, install the electric heat kit according to the installation instructions included with the kit. After installing the kit, mark the air handler nameplate to designate the heater kit that was installed. If no heater is installed, mark the name plate appropriately to indicate that no heat kit is installed.

The HEAT ENABLE jumper (See Figure 10) must be moved to the HEAT position to enable operation of the heater.

Use only 4HK heater kits, as listed on Air Handler name plate and in these instructions. Use data from Tables 10 through 19 for information on required minimum motor speed tap to be used for heating operation, maximum over-current protection device required and minimum electrical supply wiring size required – for listed combination of Air Handler and Heater Kit.

For upflow, downflow and horizontal right hand applications the kits can be installed without modification.

Field modification is required for horizontal left hand airflow application only. Follow instructions with heater for modification.

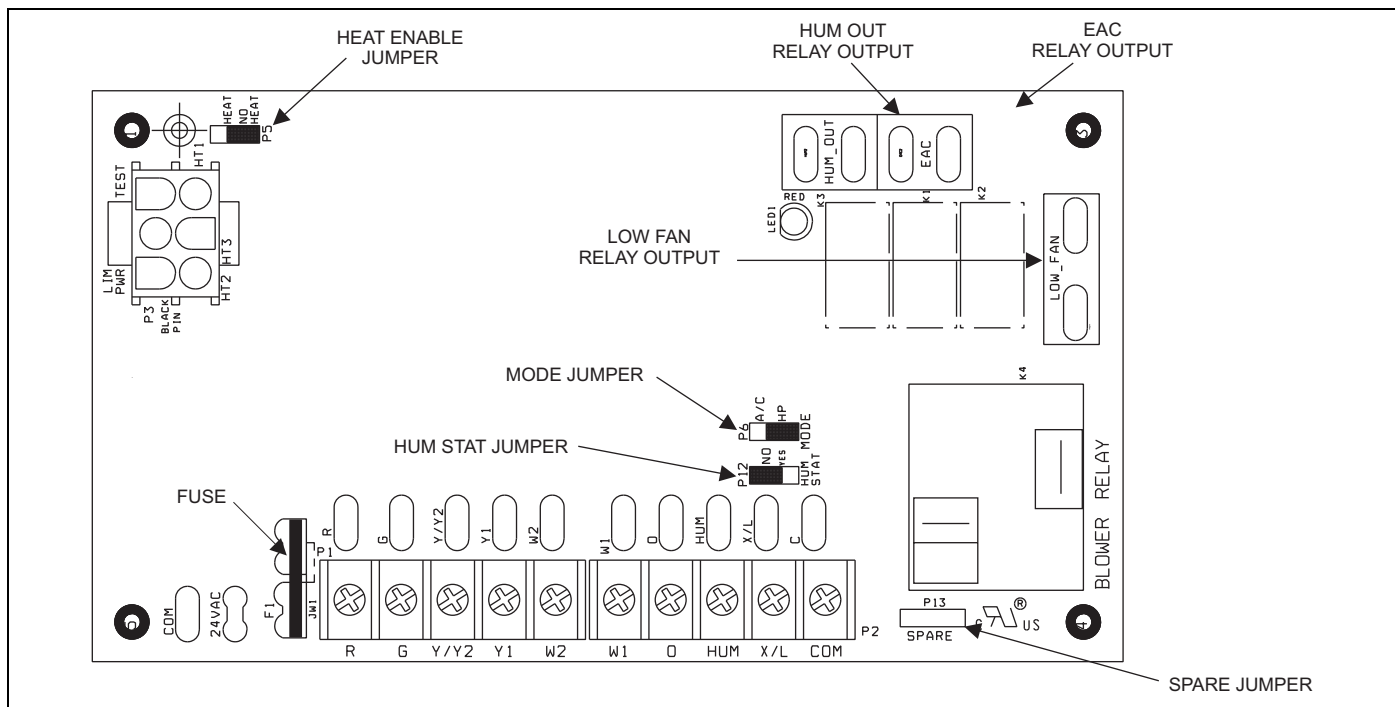

FIGURE 10: Control Board

SECTION V: LOW VOLTAGE CONTROL CONNECTIONS

The 24 volt power supply is provided by an internally wired low voltage transformer which is standard on all models. However, if the unit is connected to a 208 volt power supply, the low voltage transformer must be rewired to the 208 volt tap. See the unit wiring label.

Field supplied low voltage wiring can exit the unit on the top right hand corner or the right hand side panel. Refer to Figure 3.

Remove desired knockout and pierce foil faced insulation to allow wiring to pass through. Use as small of a hole as possible to minimize air leakage.

Install a 7/8" plastic bushing in the selected hole and keep low voltage wiring as short as possible inside the control box.

To further minimize air leakage, seal the wiring entry point at the outside of the unit.

The field wiring is to be connected at the screw terminals of the control board. Refer to Figure 10.

NOTE: All wiring must comply with local and national electrical code requirements. Read and heed all unit caution labels.

NOTE: It is possible to vary the amount of electric heat turned on during the defrost cycle of a heat pump. Standard wiring will only bring on the first stage of electric heat during defrost. See Heat Output and Limit Connections and Table 6 for additional information on heat during defrost cycle.

TABLE 2: Low Voltage Connections

Terminal	Signal	Comment
R	24 VAC power (fused)	
G	Continuous Fan operation	
Y/Y2	Second or full stage compressor operation	
Y1	First stage compressor operation	Not used with outdoor units having one stage compressors.
W2	Second stage heat operation	
W1	First stage heat operation	
O	Reversing valve operation	24 VAC will be present at this terminal when the MODE jumper is in the AC position. This is normal.
HUM	Humidity switch input	24 VAC will be present at this terminal when the HUM STAT jumper is in the NO position. This is normal.
X/L	Connection point for heat pump fault indicator	This terminal is a connection point only and does not affect air handler control operation.
COM	24 VAC common	

The low voltage connections may be connected to the screw terminals or the quick connect terminals. The screw terminals and the quick connect terminals are physically connected on the control board.

HUMIDITY SWITCH INPUT

The air handler control is designed to work with a humidity control that closes when the humidity is below the set-point. The control is open when the humidity is above the set-point. This humidity control may be referred to as a humidistat or a dehumidistat.

The humidity switch controls both humidification and de-humidification operation of the control. The control provides humidification using the HUM OUT relay output and de-humidification by lowering the blower speed. This is accomplished using the LOW FAN output and a field installed two-speed fan relay kit for non-variable speed models and the de-humidification input of the motor for variable speed models.

The humidity switch should be connected to the R and HUM terminals of the control. See Figure 10.

SECTION VI: REQUIRED CONTROL SET-UP

IMPORTANT: The following steps must be taken at the time of installation to insure proper system operation.

1. Consult system wiring diagram to determine proper thermostat wiring for your system.
2. If heat kit is installed, change HEAT ENABLE jumper from NO HEAT to HEAT position.
3. If a humidstat is installed, change HUM STAT jumper from NO to YES.
4. Set the MODE jumper to A/C (Air Conditioner) or HP (Heat Pump) position depending on the outdoor unit included with the system.

FUNCTIONALITY AND OPERATION

Jumper Positions

Heat Enable Jumper

The HEAT ENABLE jumper configures the control for heat kit operation. The jumper must be in the HEAT position if a heat kit is installed with the air handler.

With the jumper in the NO HEAT position, the control will not energize the heat relay outputs or sense the limit switch input.

If the jumper is not present, the control will operate as if the jumper is in the HEAT position. If the jumper is not present and a heat kit is not present, the control will sense an open limit condition and the blower will run continuously.

Hum Stat Jumper

The HUM STAT jumper configures the control to monitor the humidity switch input. With the jumper in the NO position, the control will energize the HUM terminal with 24 VAC continually. With the jumper in the YES position, the control will monitor the HUM input to control the HUM OUT output to control an external humidifier.

If the jumper is not present, the control will operate as if the jumper is in the YES position.

Mode Jumper

The MODE jumper configures the control to operate properly with an air conditioner (AC position) or heat pump (HP position). With the jumper in the AC position, the control will energize the O terminal with 24 VAC continually. With the jumper in the HP position, the O input signal is received from the room thermostat.

If the jumper is not present, the control will operate as if the jumper is in the HP position.

SPARE Jumper

The control includes a spare jumper that can be used if a jumper is lost. The SPARE jumper does not have any effect on the operation of the control.

Status and Fault Codes

The control includes an LED that displays status and fault codes. These codes are shown in Table 3. The control will display the fault codes until power is removed from the control or the fault condition is no longer present.

TABLE 3: Fault Codes

Fault or Status Condition	LED1 (RED) Flash Code
Status	
No power to control	OFF
Normal operation	2s ON / 2s OFF
Control in test mode	Rapid Flash
Control failure	ON
Limit Faults	
Limit switch currently open (not in lockout)	1
Multiple limit openings with no call for heat	2
Multiple limit openings during one call for heat	3
Single long duration limit opening	4
Multiple long duration limit openings	5
Fan failure	6
Wiring Related Faults	
Simultaneous call for heating and cooling	7
Internal Control Faults	
Control recovered from internal event	9

External Relay Outputs

The control includes three outputs to drive external relays having 24 VAC coils. The outputs have a maximum rating of 1.0 Amp pilot duty at 24 VAC.

HUM OUT

The HUM OUT output can be used to drive an external relay or solenoid (24 VAC coil) to control a humidifier. The output is energized when the HUM input is energized, the HUM STAT is in the YES position, and the control has a thermostat call for heating (heat pump or electric heat).

EAC

The EAC output can be used to drive an external relay (24 VAC coil) to control an electronic air cleaner. The output is energized whenever the blower relay on the control is energized. Models having a high efficiency non-variable speed motor use the EAC output as an input to the motor. The EAC output can also be used to drive an electronic air cleaner relay as long as the load of the EAC relay does not exceed 1.0 Amp. An additional connection to the EAC terminals must be made using a piggyback terminal or similar device.

LOW FAN

The LOW FAN output can be used to drive an external relay (24 VAC coil) that switches the power input to the motor to a lower speed tap. An accessory kit for use with PSC motors is available for this application; Kit S1-4SF06700124.

See Figure 12 for configuring the 5 Ton (X-13 Motor) to 2 speed (low fan) application.

The LOW FAN output is energized when the control has the following inputs.

TABLE 4: Low Fan Control Inputs

Input	Operational Mode
G	Continuous Fan operation
Y1 or Y1 and O	First stage compressor operation
Y/Y2 and HUM de-energized with HUM STAT jumper in YES position	Dehumidification during cooling

Blower Delays

The control includes the following blower delays:

TABLE 5: Blower Delays

Condition	Blower Delay
Following call for cooling	60 seconds
Following call for heat pump heating	30 seconds
Following call for electric heat heating	10 seconds

Heat Output and Limit Connections

The control is connected to the heater relays and limit switch using the 6-pin connector. The relay outputs and the limit switch signal are 24 VDC.

The control energizes the heat relays and senses the limit switch input as shown in Table 6 when the HEAT ENABLE jumper is in the HEAT position.

TABLE 6: Heat Relays

Input	Heat Relay Output
W1	HT1
W2	HT1 and HT2
W1 and W2	HT1 and HT2 and HT3

The control energizes the first stage of electric heat immediately, the second stage 10 seconds after the call for second stage heat, and the third stage 20 seconds after the call for third stage heat.

Depending on the heat kit installed in the air handler, the control provides the flexibility to configure the amount of heat delivered with the first stage heating call. As an example, when the control's W1 input is connected to the room thermostat's first stage heat signal, a call for first stage heat will energize one heating element (HT1). If the control's W2 input is connected to the room thermostat's first stage heat signal, a call for first stage heat will energize two heating elements (HT1 and HT2). With either configuration, the control will energize three heating elements (HT1, HT2, and HT3) when it receives a first and second stage heat input from the thermostat.

Limit Switch and Lockout Operation

Limit Switch Operation

If the HEAT ENABLE jumper is in the HEAT position and the limit switch opens (fault code 1), the control will immediately de-energize all electric heat relay outputs and energize the blower (if it wasn't already energized). When the limit switch closes, the control will re-energize electric heat according to the thermostat inputs using normal timings.

Fan On Lock Condition

If the limit switch opens multiple times during a single call for electric heat (fault code 3) or if the limit switch opens for a long duration (fault code 4), the control will energize the blower until power is removed from the control. The control will cycle the heat outputs on and off as the limit re-closes and opens. The constant fan operation will signal the homeowner that a problem has occurred and a service call is required.

Soft Lockout

If the limit switch opens for a second long duration period during a single call for heat (fault code 5), the control will keep the blower locked on and lock out the heat outputs for one hour. The control will only reset this one hour lockout when the power is removed from the control. After the one hour period has passed, the control will re-energize electric heat according to the thermostat inputs using normal timings. The blower will remain locked on from the first long duration limit opening.

Hard Lockout

The control has a hard lockout condition during which the control will keep all heat outputs de-energized until power is removed from the control. The control de-energizes the blower five minutes after entering the hard lockout condition.

If the limit switch closes and re-opens during the one hour soft lockout period, the control will enter a hard lockout condition and continue to indicate a fault code 5.

If the limit switch opens twice when no call for electric heat is present (fault code 2), the control will enter a hard lockout condition.

If the limit switch opens multiple times soon after a soft lockout reset (fault code 6), the control will enter a hard lockout condition.

Wiring Related Faults

If the control receives a simultaneous call for heating and cooling (fault code 7), the control will perform both heating and cooling operations.

SECTION VII: LINE POWER CONNECTIONS

Power may be brought into the unit through the supply air end of the unit (top when unit is vertical) or the left side panel. Use the hole appropriate to the unit's orientation in each installation to bring conduit from the disconnect. The power lead conduit should be terminated at the electrical control box. Refer to Tables 11, 12, 14, 16, 17 and 19 to determine proper wire sizing. Also see Figure 3. To minimize air leakage, seal the wiring entry point at the outside of the unit.

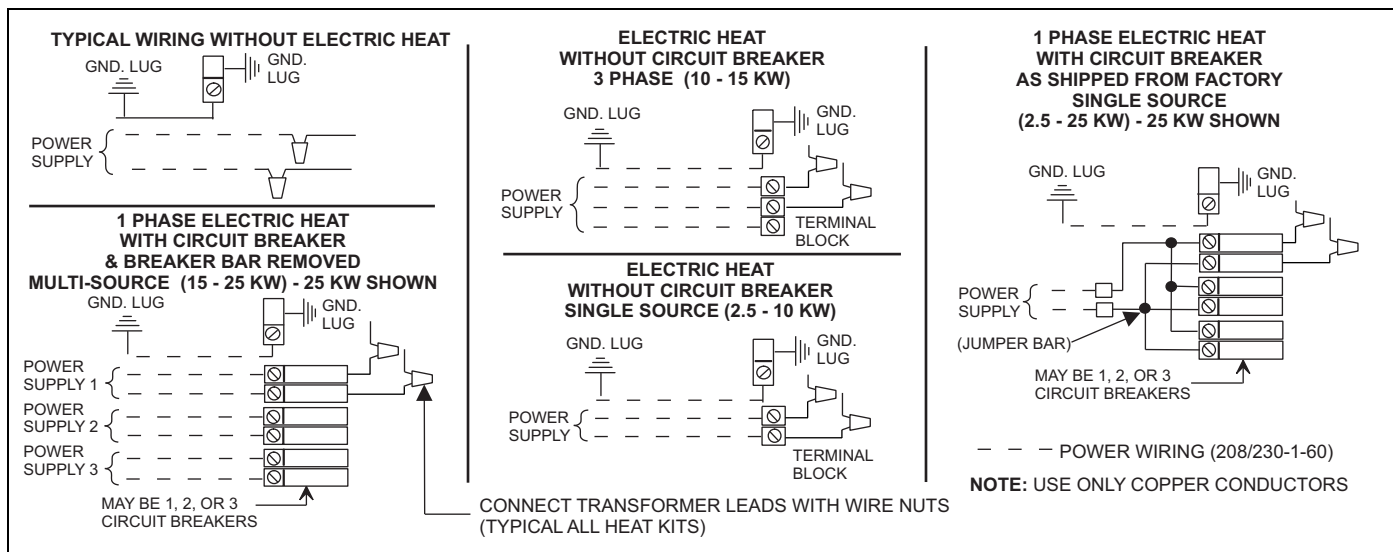

FIGURE 11: Line Power Connections

SECTION VIII: BLOWER SPEED CONNECTIONS

All air handlers, except the 5 ton (060 model), contain 3-speed blower motors. The 5 ton (060 model) has a programmed X-13 motor.

Adjust blower motor speed to provide airflow within the minimum and maximum limits approved for evaporator coil, electric heat and outdoor unit. Speed tap adjustments are made at the motor terminal block, See Figure 12. Airflow data is shown in Table 15.

Connect motor wires to motor speed tap receptacle for speed desired. See unit wiring label for motor wiring details.

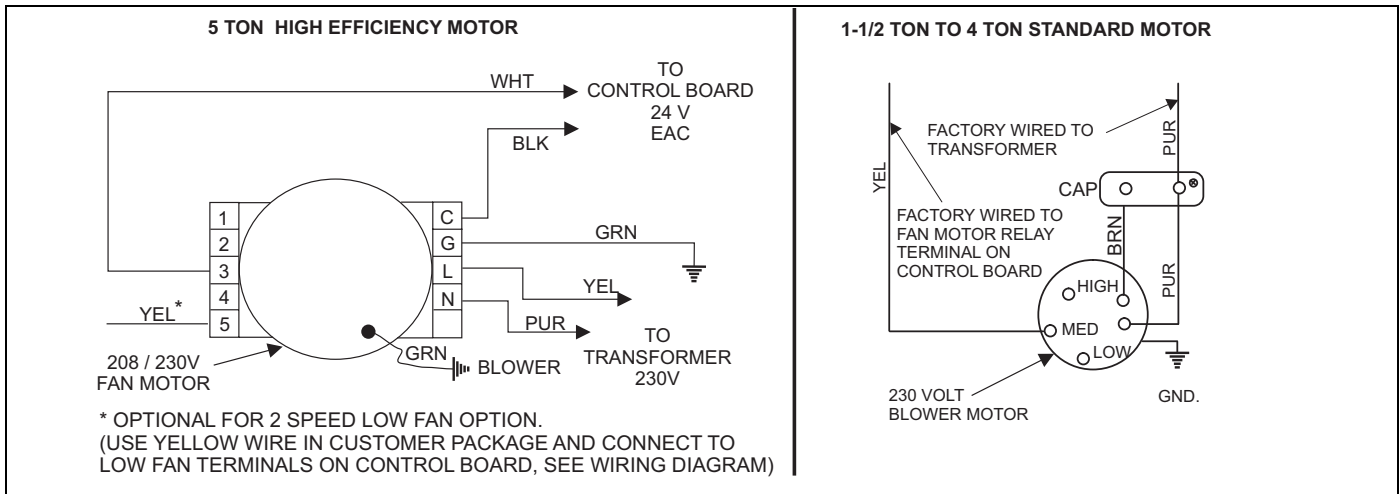

FIGURE 12: Blower Speed Connections

SECTION IX: UNIT DATA

TABLE 7: Physical and Electrical Data

Models		18B	24B	30B	36C
Blower - Diameter x Width		9 x 6	10 x 9	10 x 9	10 x 10
Motor	HP	1/3 HP	1/4 HP	1/2 HP	3/4 HP
	Nominal RPM	1075	1075	1075	1075
Voltage		230			
Amps	Full Load (230)	1.9	1.5	2.2	3.6
Filter ¹	Type	DISPOSABLE OR PERMANENT			
	Size	16 x 20 x 1	16 x 20 x 1	16 x 20 x 1	20 x 20 x 1
	Permanent Type Kit	1PF0601BK	1PF0601BK	1PF0601BK	1PF0602BK
Shipping / Operating Weight (lbs.) - N Models		128/122	132/126	139/133	162/156
Shipping / Operating Weight (lbs.) - H Models		131/125	135/129	142/136	165/159

Models		42C	48D	60D
Blower - Diameter x Width		10 x 10	10 x 10	11 x 10
Motor	HP	3/4 HP	3/4 HP	1 HP
	Nominal RPM	1075	1075	1050
Voltage		230		
Amps	Full Load (230)	3.8	3.8	7.6
Filter ¹	Type	DISPOSABLE OR PERMANENT		
	Size	20 x 20 x 1	22 x 20 x 1	22 x 20 x 1
	Permanent Type Kit	1PF0602BK	1PF0603BK	1PF0603BK
Shipping / Operating Weight (lbs.) - N Models		164/158	AHP - 186/175 SHP - 182/171	AHP - 189/178 SHP - 185/174
Shipping / Operating Weight (lbs.) - H Models		167/161	190/179	193/182

1. Field Supplied.

TABLE 8: Conversion Table

kW & MBH Conversions - for Total Power Input Requirement					
FOR	208V	OPERATION MULTI-PLY	240V	TABULATED kW & MBH BY	.751
	230V		240V		.918

TABLE 9: Electrical Data - Cooling Only (60 Hz)

Models	Total Motor Amps		Minimum Circuit Ampacity		Max. O.C.P. ¹ Amps/Type	Minimum Wire Size A.W.G.
	60 Hertz		60 Hertz			
	208V	230V	208V	230V		
18B	1.7	1.9	2.1	2.4	15	14
24B	1.4	1.5	1.8	1.9	15	14
30B	2	2.2	2.5	2.8	15	14
36C	3.3	3.6	4.1	4.5	15	14
42C	3.4	3.8	4.3	4.8	15	14
48D	3.4	3.8	4.3	4.8	15	14
60D	7.6	7.6	9.5	9.5	15	14

1. OCP = Over Current Protection device, must be HACR type Circuit Breaker or Time Delay fuse.

TABLE 10: Electrical Data - 208/230-1-60

Models	Heater Models*	Max. Static	Min. Speed Tap	Total Heat ¹				kW Staging					
				kW		MBH		W1 Only		W2 Only		W1 + W2	
				208V	230V	208V	230V	208V	230V	208V	230V	208V	230V
18B	4HK*6500206	0.5	Lo	1.9	2.5	6.4	8.5	1.9	2.5	1.9	2.5	1.9	2.5
	4HK*6500506	0.5	Med	3.6	4.8	12.3	16.4	3.6	4.8	3.6	4.8	3.6	4.8
	4HK*6500806	0.5	Med	5.6	7.5	19.2	25.6	2.8	3.75	5.6	7.5	5.6	7.5
24B	4HK*6500206	0.5	Lo	1.9	2.5	6.4	8.5	1.9	2.5	1.9	2.5	1.9	2.5
	4HK*6500506	0.5	Lo	3.6	4.8	12.3	16.4	3.6	4.8	3.6	4.8	3.6	4.8
	4HK*6500806	0.5	Med	5.6	7.5	19.2	25.6	2.8	3.75	5.6	7.5	5.6	7.5
	4HK*6501006	0.5	Hi	7.2	9.6	24.6	32.8	3.6	4.8	7.2	9.6	7.2	9.6
30B	4HK16501306	0.5	Hi	9.8	13.0	33.3	44.4	3.3	4.3	6.5	8.6	9.8	13.0
	4HK*6500506	0.5	Lo	3.6	4.8	12.3	16.4	3.6	4.8	3.6	4.8	3.6	4.8
	4HK*6500806	0.5	Med	5.6	7.5	19.2	25.6	2.8	3.75	5.6	7.5	5.6	7.5
	4HK*6501006	0.5	Hi	7.2	9.6	24.6	32.8	3.6	4.8	7.2	9.6	7.2	9.6
	4HK16501306	0.5	Hi	9.8	13.0	33.3	44.4	3.3	4.3	6.5	8.6	9.8	13.0
36C	4HK*6500506	0.5	Lo	3.6	4.8	12.3	16.4	3.6	4.8	3.6	4.8	3.6	4.8
	4HK*6500806	0.5	Lo	5.6	7.5	19.2	25.6	2.8	3.75	5.6	7.5	5.6	7.5
	4HK*6501006	0.5	Med	7.2	9.6	24.6	32.8	3.6	4.8	7.2	9.6	7.2	9.6
	4HK16501506	0.5	Med	10.8	14.4	36.9	49.1	3.6	4.8	7.2	9.6	10.8	14.4
	4HK16501806	0.5	Hi	13.2	17.6	45.1	60.1	3.3	4.4	6.6	8.8	13.2	17.6
42C	4HK*6500506	0.5	Lo	3.6	4.8	12.3	16.4	3.6	4.8	3.6	4.8	3.6	4.8
	4HK*6500806	0.5	Med	5.6	7.5	19.2	25.6	2.8	3.75	2.8	7.5	5.6	7.5
	4HK*6501006	0.5	Med	7.2	9.6	24.6	32.8	3.6	4.8	7.2	9.6	7.2	9.6
	4HK16501506	0.5	Med	10.8	14.4	36.9	49.1	3.6	4.8	7.2	9.6	10.8	14.4
	4HK16501806	0.5	Hi	13.2	17.6	45.1	60.1	3.3	4.4	6.6	8.8	13.2	17.6
48D	4HK16502006	0.5	Hi	14.4	19.2	49.2	65.5	3.6	4.8	7.2	9.6	14.4	19.2
	4HK*6500506	0.5	Lo	3.6	4.8	12.3	16.4	3.6	4.8	3.6	4.8	3.6	4.8
	4HK*6500806	0.5	Med	5.6	7.5	19.2	25.6	2.8	3.75	2.8	7.5	5.6	7.5
	4HK*6501006	0.5	Med	7.2	9.6	24.6	32.8	3.6	4.8	7.2	9.6	7.2	9.6
	4HK16501506	0.5	Med	10.8	14.4	36.9	49.1	3.6	4.8	7.2	9.6	10.8	14.4
	4HK16501806	0.5	Hi	13.2	17.6	45.1	60.1	3.3	4.4	6.6	8.8	13.2	17.6
60D	4HK16502006	0.5	Hi	14.4	19.2	49.2	65.5	3.6	4.8	7.2	9.6	14.4	19.2
	4HK*6500506	0.5	#4	3.6	4.8	12.3	16.4	3.6	4.8	3.6	4.8	3.6	4.8
	4HK*6500806	0.5	#4	5.6	7.5	19.2	25.6	2.8	3.75	2.8	7.5	5.6	7.5
	4HK*6501006	0.5	#3	7.2	9.6	24.6	32.8	3.6	4.8	7.2	9.6	7.2	9.6
	4HK16501506	0.5	#2	10.8	14.4	36.9	49.1	3.6	4.8	7.2	9.6	10.8	14.4
	4HK16501806	0.5	#2	13.2	17.6	45.1	60.1	3.3	4.4	6.6	8.8	13.2	17.6

1. See conversion Table 9.

2. AHP30B w/4HK165N1506 only approved for use up to 0.4" static.

* May be 0 (no breaker) or 1 (with breaker).

TABLE 11: Electrical Data - (For Single Source Power Supply) - Copper Wire - 208/230-1-60

Models	Heater Models*	Heater Amps 240V	Field Wiring					
			Min. Circuit Ampacity		Max. O.C.P. ¹ Amps/Type		75°C Wire Size - AWG	
			208V	230V	208V	230V	208V	230V
18B	4HK*6500206	10.4	13.5	15.4	15	20	12	12
	4HK*6500506	20.0	23.8	27.4	25	30	10	10
	4HK*6500806	31.3	36.0	41.5	40	45	8	8
24B	4HK*6500206	10.4	13.0	14.9	15	15	12	12
	4HK*6500506	20.0	23.4	26.9	25	30	10	10
	4HK*6500806	31.3	35.6	41.0	40	45	8	8
	4HK*6501006	40.0	45.1	51.9	45	60	8	6
	4HK16501306	54.2	60.4	69.6	70	70	4	4
30B	4HK*6500506	20.0	24.2	27.8	25	30	10	10
	4HK*6500806	31.3	36.4	41.9	40	45	8	8
	4HK*6501006	40.0	45.8	52.8	50	60	8	6
	4HK16501306	54.2	60.1	70.5	70	90	4	3
	4HK165N1506	60.0	67.5	77.8	70	90	4	3
36C	4HK*6500506	20.0	25.8	29.5	30	30	10	10
	4HK*6500806	31.3	38.0	43.6	40	45	8	8
	4HK*6501006	40.0	47.5	54.5	50	60	8	6
	4HK16501506	60.0	69.1	79.5	70	90	4	3
	4HK16501806	73.3	83.6	96.1	90	100	3	3
42C	4HK*6500506	20.0	25.9	29.8	30	30	8	8
	4HK*6500806	31.3	38.1	43.9	40	45	8	8
	4HK*6501006	40.0	47.6	54.8	50	60	6	6
	4HK16501506	60.0	69.3	79.8	70	90	4	3
	4HK16501806	73.3	83.7	96.4	90	100	3	3
	4HK16502006	80.0	90.9	104.8	100	110	3	2
48D	4HK*6500506	20.0	25.9	29.8	30	30	10	10
	4HK*6500806	31.3	38.1	43.9	40	45	8	8
	4HK*6501006	40.0	47.6	54.8	50	60	8	6
	4HK16501506	60.0	69.3	79.8	70	90	4	3
	4HK16501806	73.3	83.7	96.4	90	100	3	3
	4HK16502006	80.0	90.9	104.8	100	110	3	2
60D	4HK*6500506	20.0	31.2	34.5	35	35	8	8
	4HK*6500806	31.3	43.4	48.6	45	50	8	8
	4HK*6501006	40.0	52.8	59.5	60	60	6	6
	4HK16501506	60.0	74.5	84.5	90	90	3	3
	4HK16501806	73.3	88.9	101.1	90	110	3	2
	4HK16502006	80.0	96.2	109.5	100	125	3	1
	4HK16502506	100.0	117.8	134.5	125	150	1	1/0

1. O.C.P. = Over Current Protection device, must be HACR type Circuit Breaker or Time Delay fuse.

* May be 0 (no breaker) or 1 (with breaker).

TABLE 12: Electrical Data - (For **Multi-Source** Power Supply) - Copper Wire - 208/230-1-60

Models	Heater Models	Min. Circuit Ampacity			Max. O.C.P. ¹ Amps/Type			75°C Wire Size - AWG		
		Circuit			Circuit			Circuit		
		1st	2nd	3rd	1st	2nd	3rd	1st	2nd	3rd
		208/230	208/230	208/230	208/230	208/230	208/230	208/230	208/230	208/230
24B	4HK16501306	40.9/47.0	19.5/22.5	–	45/50	20/25	–	8/8	10/10	–
30B	4HK16501306	41.6/47.9	19.5/22.5	–	45/50	20/25	–	8/8	10/10	–
	4HK165N1506	45.8/52.8	21.7/25.0	–	50/60	25/25	–	8/6	10/10	–
36C	4HK16501506	47.5/54.5	21.7/25.0	–	50/60	25/25	–	8/6	10/10	–
	4HK16501806	43.9/50.3	39.8/45.8	–	45/60	40/50	–	8/6	8/8	–
42C	4HK16501506	47.6/54.8	21.7/25.0	–	50/60	25/25	–	8/6	10/10	–
	4HK16501806	44.0/50.6	39.8/45.8	–	45/60	40/50	–	8/6	8/8	–
	4HK16502006	47.6/54.8	43.4/50.0	–	50/60	40/50	–	8/6	8/8	–
48D	4HK16501506	47.6/54.8	21.7/25.0	–	50/60	25/25	–	8/6	10/10	–
	4HK16501806	44.0/50.6	39.8/45.8	–	45/60	40/50	–	8/6	8/8	–
	4HK16502006	47.6/54.8	43.4/50.0	–	50/60	40/50	–	8/6	8/8	–
60D	4HK16501506	52.9/59.5	21.7/25.0	–	60/60	25/25	–	6/6	10/10	–
	4HK16501806	49.3/55.3	39.8/45.8	–	50/60	45/60	–	6/6	8/6	–
	4HK16502006	52.9/59.5	43.4/50.0	–	60/60	45/50	–	6/6	8/8	–
	4HK16502506	52.9/59.5	43.4/50.0	21.68/25.00	60/60	45/50	25/25	6/6	8/8	10/10

1. O.C.P. = Over Current Protection device, must be HACR type Circuit Breaker or Time Delay fuse.

TABLE 13: Electrical Data - 208/230-3-60

Models	Heat Kit - Three Phase	Max. Static	Min. Speed Tap	Total Heat ¹				KW Staging					
				KW		MBH		W1 Only		W2 Only		W1 + W2	
				208V	230V	208V	230V	208V	230V	208V	230V	208V	230V
24B	4HK06501025	0.5	Hi	7.2	9.6	24.6	32.8	7.2	9.6	7.2	9.6	7.2	9.6
30B	4HK06501025	0.5	Hi	7.2	9.6	24.6	32.8	7.2	9.6	7.2	9.6	7.2	9.6
	4HK065N1525	0.5	Hi	10.8	14.4	36.9	49.1	10.8	14.4	10.8	14.4	10.8	14.4
36C	4HK06501025	0.5	Med	7.2	9.6	24.6	32.8	7.2	9.6	7.2	9.6	7.2	9.6
	4HK06501525	0.5	Med	10.8	14.4	36.9	49.1	10.8	14.4	10.8	14.4	10.8	14.4
42C	4HK06501025	0.5	Med	7.2	9.6	24.6	32.8	7.2	9.6	7.2	9.6	7.2	9.6
	4HK06501525	0.5	Med	10.8	14.4	36.9	49.1	10.8	14.4	10.8	14.4	10.8	14.4
	4HK06501825	0.5	Hi	12.9	17.2	44.7	58.7	12.9	17.2	12.9	17.2	12.9	17.2
48D	4HK06501025	0.5	Med	7.2	9.6	24.6	32.8	7.2	9.6	7.2	9.6	7.2	9.6
	4HK06501525	0.5	Med	10.8	14.4	36.9	49.1	10.8	14.4	10.8	14.4	10.8	14.4
	4HK06501825	0.5	Hi	12.9	17.2	44.7	58.7	12.9	17.2	12.9	17.2	12.9	17.2
60D	4HK06501025	0.5	#3	7.2	9.6	24.6	32.8	7.2	9.6	7.2	9.6	7.2	9.6
	4HK06501525	0.5	#4	10.8	14.4	36.9	49.1	10.8	14.4	10.8	14.4	10.8	14.4
	4HK16501825	0.5	#4	12.9	17.2	44.7	58.7	12.9	17.2	12.9	17.2	12.9	17.2
	4HK16502525	0.5	#4	18.0	24.0	61.4	81.4	9.0	12.0	18.0	24.0	18.0	24.0

1. See conversion Table 10.

TABLE 14: Electrical Data - (For **Single Source** Power Supply) - Copper Wire - 208/230-3-60

Models	Heat Kit - Three Phase	Heater Amps 240V	Field Wiring					
			Min. Circuit Ampacity		Max. O.C.P. ¹ Amps/Type		75°C Wire Size - AWG	
			208V	230V	208V	230V	208V	230V
24B	4HK06501025	23.1	27.1	31.3	30	35	10	8
30B	4HK06501025	23.1	26.8	30.8	30	35	10	8
	4HK065N1525	34.7	40.0	46.1	40	50	8	8
36C	4HK06501025	23.1	27.5	31.6	30	35	10	8
	4HK06501525	34.7	40.0	46.1	40	50	8	8
42C	4HK06501025	23.1	29.1	33.4	30	35	10	8
	4HK06501525	34.7	41.6	47.9	50	50	8	8
	4HK06501825	41.4	48.9	56.3	50	60	8	6
48D	4HK06501025	23.1	29.3	33.6	30	35	10	8
	4HK06501525	34.7	41.8	48.1	50	50	8	8
	4HK06501825	41.4	49.0	56.5	50	60	8	6
60D	4HK06501025	23.1	34.5	38.4	35	40	8	8
	4HK06501525	34.7	47.0	52.9	50	60	8	6

- O.C.P. = Over Current Protection device, must be HACR type Circuit Breaker or Time Delay fuse.
- Heaters are 3 Phase.

TABLE 15: Electrical Data - (For **Multi-Source** Power Supply) - Copper Wire - 208/230-3-60

Models	Heater Model	Minimum Circuit Ampacity			Max. O.C.P. ¹ Amps/Type			75°C Wire Size - AWG		
		Circuit								
		1st	2nd	3rd	1st	2nd	3rd	1st	2nd	3rd
		208/230	208/230	208/230	208/230	208/230	208/230	208/230	208/230	208/230
60D	4HK16501825	31.9/35.4	22.4/25.9	-/-	35/40	25/30	-/-	8/8	10/10	-/-
	4HK16502525	40.8/45.6	31.3/36.1	-/-	45/50	35/40	-/-	8/8	8/8	-/-

- O.C.P. = Over Current Protection device, must be HACR type Circuit Breaker or Time Delay fuse.

TABLE 16: Air Flow Data - 60 Hz Models - 208 Volt

Models	Blower Motor Speed	208 Volt																			
		CFM ¹ @ External Static Pressure - IWC										m ³ /min @ External Static Pressure - kPa									
		0.10	0.20	0.30	0.40	0.50	0.60	0.70	0.80	0.90	1.00	.025	.050	.075	.100	.125	.150	.175	.200	.225	.250
18B	High-1	1142	1096	1053	997	925	828	721	210	N/A	N/A	32.3	31.0	29.8	28.2	26.2	23.4	20.4	5.9	N/A	N/A
	Medium-3	677	652	634	615	572	486	295	120	N/A	N/A	19.2	18.5	18.0	17.4	16.2	13.8	8.4	3.4	N/A	N/A
	Low-5	442	427	395	361	289	209	114	N/A	N/A	N/A	12.5	12.1	11.2	10.2	8.2	5.9	3.2	N/A	N/A	N/A
24B	High-1	1084	1038	985	935	856	762	665	602	484	333	30.7	29.4	27.9	26.5	24.2	21.6	18.8	17.0	13.7	9.4
	Medium-3	840	807	767	693	610	550	485	387	323	221	23.8	22.9	21.7	19.6	17.3	15.6	13.7	11.0	9.1	6.3
	Low-5	654	614	548	483	420	349	302	218	179	130	18.5	17.4	15.5	13.7	11.9	9.9	8.6	6.2	5.1	3.7
30B	High-1	1244	1184	1138	1079	1004	903	841	674	580	457	35.2	33.5	32.2	30.6	28.4	25.6	23.8	19.1	16.4	12.9
	Medium-3	956	913	868	815	748	663	574	487	384	N/A	27.1	25.9	24.6	23.1	21.2	18.8	16.3	13.8	10.9	N/A
	Low-5	941	904	862	806	731	643	566	480	361	226	26.6	25.6	24.4	22.8	20.7	18.2	16.0	13.6	10.2	6.4
36C	High-1	1719	1650	1572	1482	1386	1273	1108	925	785	644	48.7	46.7	44.5	42.0	39.2	36.0	31.4	26.2	22.2	18.2
	Medium-3	1119	1097	1062	1019	935	827	743	637	479	337	31.7	31.1	30.1	28.9	26.5	23.4	21.0	18.0	13.6	9.5
	Low-5	929	910	877	825	760	685	616	508	372	221	26.3	25.8	24.8	23.4	21.5	19.4	17.4	14.4	10.5	6.3
42C	High-1	1719	1650	1572	1482	1386	1273	1108	925	785	644	48.7	46.7	44.5	42.0	39.2	36.0	31.4	26.2	22.2	18.2
	Medium-3	1119	1097	1062	1019	935	827	743	637	479	337	31.7	31.1	30.1	28.9	26.5	23.4	21.0	18.0	13.6	9.5
	Low-5	929	910	877	825	760	685	616	508	372	221	26.3	25.8	24.8	23.4	21.5	19.4	17.4	14.4	10.5	6.3
048D	High-1	1941	1818	1675	1532	1269	870	703	362	146	N/A	55.0	51.5	47.4	43.4	35.9	24.6	19.9	10.3	4.1	N/A
	Medium-3	1594	1474	1409	1260	1021	802	524	215	144	N/A	45.1	41.7	39.9	35.7	28.9	22.7	14.8	6.1	4.1	N/A
	Low-5	1241	1204	1128	1014	819	659	385	165	N/A	N/A	35.1	34.1	31.9	28.7	23.2	18.7	10.9	4.7	N/A	N/A
60D	High-1	2126	2093	2074	2048	1991	1941	1801	1569	1461	1366	60.2	59.3	58.7	58.0	56.4	55.0	51.0	44.4	41.4	38.7
	Med-High/-2	1863	1842	1804	1800	1758	1730	1662	1503	1383	1306	52.8	52.2	51.1	51.0	49.8	49.0	47.1	42.6	39.2	37.0
	Medium-3	1642	1603	1593	1568	1523	1471	1410	1334	1307	1216	46.5	45.4	45.1	44.4	43.1	41.7	39.9	37.8	37.0	34.4
	Med-Low/-4	1482	1468	1427	1370	1324	1274	1233	1196	1153	1099	42.0	41.6	40.4	38.8	37.5	36.1	34.9	33.9	32.6	31.1
	Low-5	1268	1220	1169	1118	1070	1037	983	949	892	831	35.9	34.5	33.1	31.7	30.3	29.4	27.8	26.9	25.3	23.5

1. Includes return air filter and coil.

Air handler units are UL Listed up to 1/2" w.c. external static pressure, including air filter, wet coil, and largest kW size heater, unless otherwise noted.

TABLE 17: Air Flow Data - 60 Hz Models - 230 Volt

Models	Blower Motor Speed	230 Volt																			
		CFM ¹ @ External Static Pressure - IWC										m ³ /min @ External Static Pressure - Pascal									
		0.10	0.20	0.30	0.40	0.50	0.60	0.70	0.80	0.90	1.00	.003	.005	.008	.010	.013	.015	.018	.020	.023	.025
18B	High-1	1054	989	923	862	791	665	581	202	N/A	N/A	29.9	28.0	26.1	24.4	22.4	18.9	16.5	5.7	N/A	N/A
	Medium-3	782	762	716	670	613	536	315	121	N/A	N/A	22.1	21.6	20.3	19.0	17.4	15.2	8.9	3.4	N/A	N/A
	Low-5	541	519	479	445	397	298	168	N/A	N/A	N/A	15.3	14.7	13.6	12.6	11.2	8.4	4.8	N/A	N/A	N/A
24B	High-1	1232	1167	1098	1025	940	826	731	622	486	345	34.9	33.0	31.1	29.0	26.6	23.4	20.7	17.6	13.8	9.8
	Medium-3	966	915	868	799	724	641	540	452	347	224	27.4	25.9	24.6	22.6	20.5	18.2	15.3	12.8	9.8	6.3
	Low-5	785	740	684	618	532	446	364	296	192	131	22.2	21.0	19.4	17.5	15.1	12.6	10.3	8.4	5.4	3.7
30B	High-1	1434	1359	1297	1220	1138	1050	916	782	640	519	40.6	38.5	36.7	34.6	32.2	29.7	25.9	22.1	18.1	14.7
	Medium-3	1112	1076	1031	970	907	802	629	507	394	380	31.5	30.5	29.2	27.5	25.7	22.7	17.8	14.4	11.2	10.8
	Low-5	885	854	821	751	686	625	547	459	350	N/A	25.1	24.2	23.3	21.3	19.4	17.7	15.5	13.0	9.9	N/A
36C	High-1	1760	1681	1607	1538	1456	1360	1322	1260	966	770	49.8	47.6	45.5	43.6	41.2	38.5	37.4	35.7	27.4	21.8
	Medium-3	1320	1284	1255	1207	1146	1075	988	846	729	572	37.4	36.4	35.5	34.2	32.5	30.4	28.0	24.0	20.6	16.2
	Low-5	1146	1119	1090	1038	992	972	841	725	617	496	32.5	31.7	30.9	29.4	28.1	27.5	23.8	20.5	17.5	14.0
42C	High-1	1883	1764	1657	1543	1435	1327	1210	912	714	527	53.3	50.0	46.9	43.7	40.6	37.6	34.3	25.5	20.2	14.9
	Medium-3	1625	1510	1429	1339	1256	1172	1038	765	609	412	46.0	42.8	40.5	37.9	35.6	33.2	29.4	21.7	17.2	11.7
	Low-5	1260	1225	1179	1110	1047	973	785	638	500	340	35.7	34.7	33.4	31.4	29.7	27.6	22.2	18.1	14.2	9.6
48D	High-1	2029	1944	1837	1743	1643	1537	1435	1320	1064	789	57.5	55.0	52.0	49.4	46.5	43.5	40.6	37.4	30.1	22.3
	Medium-3	1805	1730	1649	1566	1479	1385	1286	1147	851	683	51.1	49.0	46.7	44.4	41.9	39.2	36.4	32.5	24.1	19.3
	Low-5	1491	1441	1388	1328	1253	1174	1076	867	726	555	42.2	40.8	39.3	37.6	35.5	33.2	30.5	24.6	20.6	15.7
60D	High-1	2256	2226	2198	2159	2095	1959	1914	1776	1519	1380	63.9	63.0	62.2	61.1	59.3	55.5	54.2	50.3	43.0	39.1
	Med-High-2	1990	1963	1935	1893	1857	1820	1783	1698	1486	1353	56.4	55.6	54.8	53.6	52.6	51.5	50.5	48.1	42.1	38.3
	Medium-3	1774	1748	1704	1670	1635	1593	1534	1480	1384	1325	50.2	49.5	48.3	47.3	46.3	45.1	43.4	41.9	39.2	37.5
	Med-Low-4	1557	1523	1483	1432	1389	1329	1265	1235	1198	1167	44.1	43.1	42.0	40.6	39.3	37.6	35.8	35.0	33.9	33.1
	Low-5	1340	1300	1253	1198	1126	1079	1037	1007	954	912	37.9	36.8	35.5	33.9	31.9	30.6	29.4	28.5	27.0	25.8

1. Includes return air filter and coil.

Air handler units are UL Listed up to 1/2" w.c. external static pressure, including air filter, wet coil, and largest kW size heater, unless otherwise noted.

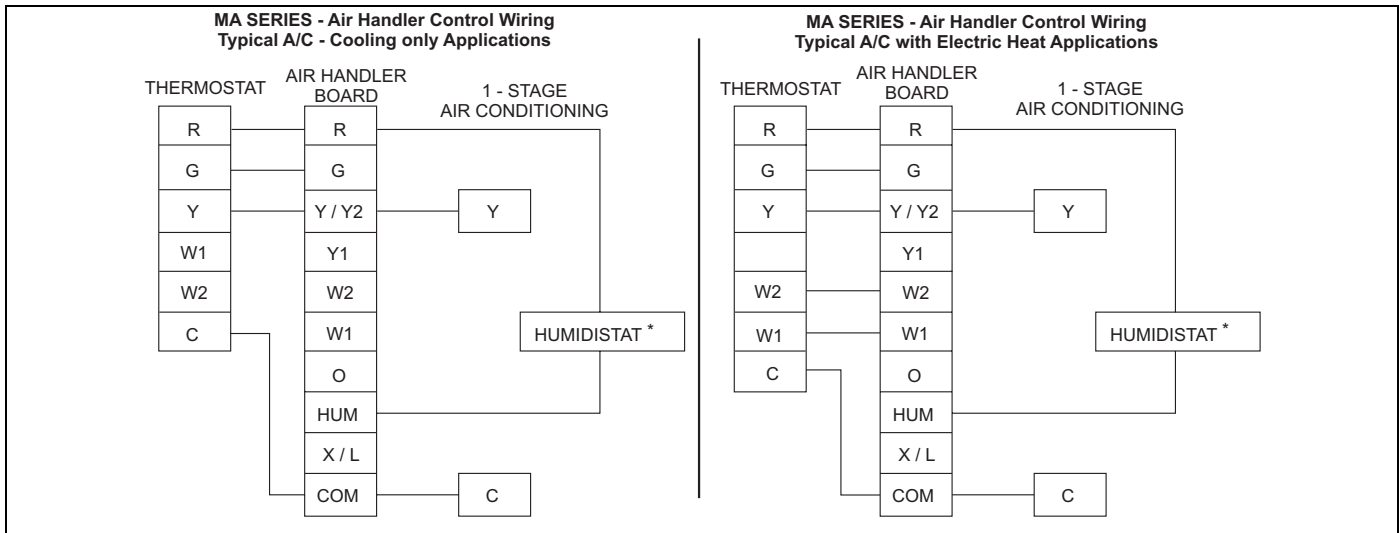

FIGURE 13: Cooling Models with Electric Heat Wiring

* Optional dehumidification humidistat switch contacts open on humidity rise.

Notes:

1. "Y" Terminal on Air Handler Control Board must be connected for full CFM and applications requiring 60 second blower off delay for SEER enhancement.
2. Move HUM STAT Jumper on AH Control Board to YES position if Humidistat is used.
3. MODE Jumper on AH control board should be set to A/C for air conditioners.

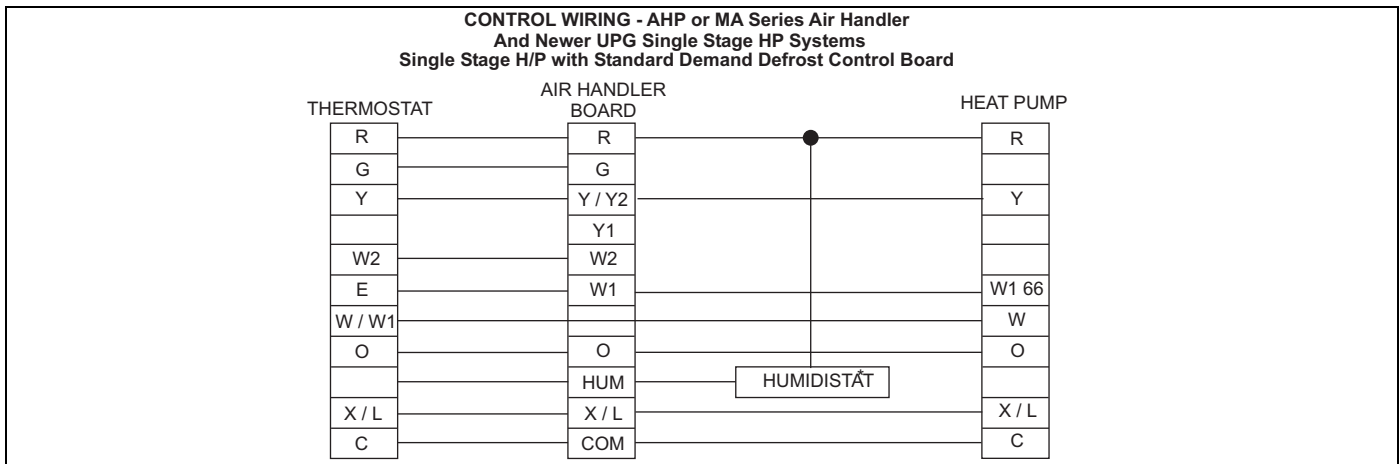

FIGURE 14: Single-Stage Cooling Wiring

* Optional dehumidification humidistat switch contacts open on rise.

Notes:

1. "Y" Terminal on Air Handler Control Board must be connected for full CFM and applications requiring 60 second blower off delay for SEER enhancement.
2. Move HUM STAT Jumper on AH Control Board to YES position if Humidistat is used.
3. MODE Jumper on AH control board should be set to HP for heat pumps.
4. To change quantity of heat during HP defrost cycle - Reverse connections at W1 & W2 on Air Handler Control Board.

SECTION X: MAINTENANCE

Filters must be cleaned or replaced when they become dirty. Inspect at least once per month. The frequency of cleaning depends upon the hours of operation and the local atmospheric conditions. Clean filters keep unit efficiency high.

COIL CLEANING

If the coil needs to be cleaned or replaced, it should be washed with Calgon CalClean (mix one part CalClean to seven parts water). Allow solution to remain on coil for 30 minutes before rinsing with clean water. Solution should not be permitted to come in contact with painted surfaces.

LUBRICATION

The bearings of the blower motor are permanently lubricated.

CONDENSATE DRAINS

During the cooling season check the condensate drain lines to be sure that condensate is flowing from the primary drain but not from the secondary drain. If condensate ever flows from the secondary drain the unit should be promptly shut off and the condensate pan and drains cleaned to insure a free flowing primary drain.