

Frigidaire

Freezers + Specialty Products



Frigidaire

Fresh thinking in every appliance.

When you think about innovation and convenience, think Frigidaire®.

And, when you think capacity, think the Frigidaire® Duo.

With over 33 cubic feet of food storage, our Professional Series® Duo is the largest capacity, counter-depth, side-by-side system in the industry. And, thanks to our dynamic condenser system, you have a unique built-in capability for a look that fits seamlessly in any room.

Crisp design? Think Frigidaire® upright and chest freezers.

From the industry's first frost-free chest freezer, to digital temperature controls and alarms, to unique storage dividers and sliding baskets, to the Extreme Freeze function that locks in freshness and nutrition, Frigidaire® offers the quality you expect and the convenience you deserve.

You expect all this from Frigidaire®... and we deliver.



All-Freezer/All-Refrigerator Duo Features



EasyCare™ Genuine Stainless Steel
All surfaces feature a protective micro-coating to minimize fingerprints and smudges and reduce maintenance.



Full-Access Sliding Storage Baskets
Allow you to organize and store frozen food easily. The wire construction securely stores larger packages and provides complete visibility of contents.



Door Storage
The clear adjustable bins and full-width gallon bin offer maximum storage capacity in the door with the convenience to lift and snap the adjustable bins into place with one hand.



Tilt-Out Wire Door Bins
Help you store a variety of frozen food items in a smaller space. The wire construction securely stores small packages and allows complete visibility of contents, while the tilt-out feature gives you easy access.

Frigidaire



Optional Trim Kits
To create a more built-in look, optional trim kits are available for a stand-alone refrigerator, stand-alone freezer, or for both units together in a side-by-side configuration.



Professional Series®

All-Freezer/All-Refrigerator Duo

PLFU1778E S / PLRU1778E S

33.7 Total Cubic Feet

All Freezer:

- EasyCare™ Genuine Stainless Steel Door
- UltraPro Stainless Steel Handle
- 2 Full-Width Cantilever Glass Shelves
- 1 Full-Width Sliding Glass Shelf
- 2 Full-Access Sliding Storage Baskets
- 2 Tilt-Out Wire Door Bins
- 3 Full-Width Fixed White Door Bins
- Mid-Level Lighting
- Ice Maker-Ready (IM501)
- 4 Adjustable Leg Levelers
- Dynamic Condenser Allows for Built-In Applications
- Optional Trim Kit Available (ALLFRZKIT)

All Refrigerator:

- EasyCare™ Genuine Stainless Steel Door
- UltraPro Stainless Steel Handle
- 3 Full-Width Cantilever Glass Shelves
- 1 Full-Width Fixed Glass Shelf
- 4 Adjustable Clear Door Bins
- 1 Full-Width Fixed White Gallon Door Bin
- Clear Dairy Door
- Clear Deli Drawer
- 2 Clear Crispers
- 1 Humidity Control
- Mid-Level Lighting
- Tall Bottle Retainer
- Tall Bottle Caddy
- 4 Adjustable Leg Levelers
- Dynamic Condenser Allows for Built-In Applications
- Optional Trim Kit Available (ALLREFKIT)

Shown above with optional Duo Trim Kit (DUOTRIMKIT)

Why buy a freezer?

Freezing is the healthiest way to preserve the fresh, natural flavors and nutrients of produce, meats and fish. Just ask any gardener, hunter or fisherman. Even if the only hunting you do is for bargains in the frozen food aisle of your grocery store, an upright freezer provides cost-effective storage that lets you enjoy the full value of bulk purchasing. Frigidaire® is the world's largest manufacturer of residential freezers. Our 20 cu. ft. upright freezer with easy-to-organize StorMor™ shelves and baskets, holds up to 700 pounds of food while consuming no more floor space than a 5 cu. ft. chest freezer. So, you'll have ample storage capacity without taking up valuable floor space in your garage, laundry room or basement. And, the commercial grade Frigidaire® upright freezer is frost free. So you'll never have to unload, unplug or drain your freezer again.

Our upright freezers hold about 35 pounds of food per cubic foot. Frigidaire® has the right fit and storage capacity for any size family.

14 Cu. Ft.
Holds up to 490 lbs. of food.



17 Cu. Ft.
Holds up to 595 lbs. of food.



20 Cu. Ft.
Holds up to 700 lbs. of food.



Frigidaire

Choosing the right freezer for you.

According to the National Association of Home Builders, your purchase of a freezer today is an investment that you'll live with for twelve or more years. In addition to the purchase price, careful consideration should be given to style, safety, convenience, economy and warranty.



Style

Consider the product and its location in your home. Will an upright or chest freezer work better for you? Frigidaire® freezers look smart enough to fit in your kitchen but they're durable enough for your basement or garage.

Economy

Freezer Energy Consumption vs. 100 Watt Light Bulb

Freezer Model	Kwh/yr Usage	vs. 100 Watt Bulb
Upright 14 Cu. Ft.	621	41.06%
Upright 17 Cu. Ft.	685	28.45%
Upright 20 Cu. Ft.	763	14.81%
Chest 15 Cu. Ft.	398	120.65%
Chest 20 Cu. Ft.	484	82.50%
Chest 25 Cu. Ft.	569	53.95%

What you pay for a freezer is one thing. How the freezer pays for itself is another. Not only are Frigidaire® freezers affordable but they're economical to operate. For instance, a 14 cu. ft. Frigidaire® upright freezer annually consumes less than half the energy needed to light a 100 watt bulb for the same period of time.



Convenience

All Frigidaire® upright freezers have loads of shelf and bin storage to keep foods within sight and within reach. Many models are frost free for the ultimate in convenience.

Quality Construction

Frigidaire freezers utilize a durable epoxy powder coated finish on a rugged steel liner for many years of reliability and durability.



Food Safety

All upright models have a Door Closer feature, Magnetic Door Gaskets for an air-tight seal, a Power-On Light and a Temperature Alarm System which sounds if the interior temperature rises to an unsafe level.

Upright Freezer Features



Lock with Pop-Out Key
For maximum security, freezer key is automatically ejected upon locking.



Precision Set™ Digital Control
Digital Control panel makes temperature adjustments easy.



UltraPro Color-Coordinated Steel Handle
Designed for your complete comfort, UltraPro handles are color coordinated with the freezer exterior.



StorMor™ Tilt-Out Wire Door Bins
Store more in less space. The wire bin construction stores small packages and optimizes visibility while the tilt-out feature provides easy access.



Small Item Shelf
The Small Item Shelf attaches securely to any horizontal shelf and is ideal for juice cans and other small items.



StorMor™ Flexible Door Storage
Flexible shelf restraints expand to accommodate odd-sized items and give you just a little more storage room when you need it.



Temp Alarm System
Warning light and buzzer alert you to interior temperatures unsafe for proper food storage.



Extreme Freeze
Extreme Freeze allows you to quick-freeze meat, poultry, produce and dairy products to lock in flavor and minimize the risk of spoilage.

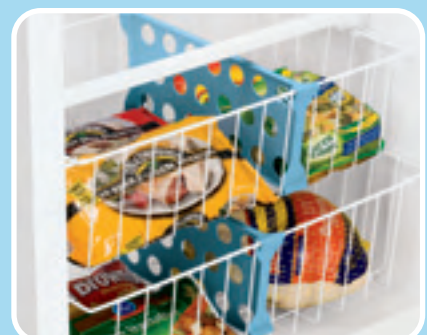

StorMor™ Full-Access Sliding Storage Baskets with Dividers
The wire bin construction securely stores larger packages while providing complete visibility. Bin dividers allow you to compartmentalize your storage for complete organization.

Frigidaire

Frigidaire
GALLERY™

GLFU2067F W

20.3 Cubic Feet

- Frost Free
- Precision Set™ Control
- 2 Full-Width Adjustable Glass Shelves
- 2 Full-Width Fixed Glass Shelves
- 2 Full-Access Sliding Storage Baskets with 2 Dividers
- 4 Full-Width Fixed Door Bins
- 2 Tilt-Out Wire Door Bins
- Small Item Shelf
- Lock with Pop-Out Key
- Interior Light
- Temp Alarm System
- Door Ajar Alarm
- Display Mode
- Child Lock
- Extreme Freeze
- 2 Adjustable Leg Levelers
- UltraPro Color-Coordinated Steel Handle
- Automatic Door Closer
- Ice Maker-Ready

Dimensions:

70" H x 32" W x 28-1/2" D
(Cabinet depth includes door)

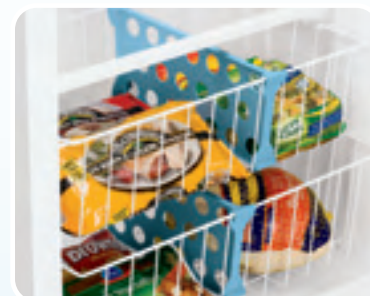

Frigidaire
GALLERY™

GLFU1767F W

16.7 Cubic Feet

- Frost Free
- Precision Set™ Control
- 2 Full-Width Adjustable Glass Shelves
- 2 Fixed Glass Shelves
- 2 Full-Access Sliding Storage Baskets with 2 Dividers
- 3 Full-Width Fixed Door Bins
- 2 Tilt-Out Wire Door Bins
- Small Item Shelf
- Lock with Pop-Out Key
- Interior Light
- Temp Alarm System
- Door Ajar Alarm
- Display Mode
- Child Lock
- Extreme Freeze
- 2 Adjustable Leg Levelers
- UltraPro Color-Coordinated Steel Handle
- Automatic Door Closer

Dimensions:

64-1/2" H x 32" W x 26-1/2" D

(Cabinet depth includes door)



Frigidaire
GALLERY™

GLFU1467F W

13.7 Cubic Feet

- Frost Free
- Precision Set™ Control
- 3 Fixed Glass Shelves
- 1 Full-Access Sliding Storage Basket with Divider
- 4 Full-Width Fixed Door Bins
- 1 Tilt-Out Wire Door Bin
- Small Item Shelf
- Lock with Pop-Out Key
- Interior Light
- Temp Alarm System
- Door Ajar Alarm
- Display Mode
- Child Lock
- Extreme Freeze
- 2 Adjustable Leg Levelers
- UltraPro Color-Coordinated Steel Handle
- Automatic Door Closer

Dimensions:

59" H x 28" W x 28-1/2" D

(Cabinet depth includes door)



Frigidaire



Frigidaire®
FFU2065F W
 20.3 Cubic Feet

- Frost Free
- Easy Set™ Control
- 4 Fixed Wire Shelves
- 1 Adjustable Wire Shelf
- 1 Full-Access Sliding Storage Basket
- 5 Full-Width Fixed Door Bins
- 1 Tilt-Out Wire Door Bin
- Lock with Pop-Out Key
- Interior Light
- Power-On Light
- Temp Alarm System
- 2 Adjustable Leg Levelers
- Color-Coordinated Handle
- Automatic Door Closer

Dimensions:
 70" H x 32" W x 28-1/2" D
 (Cabinet depth includes door)



Frigidaire®
FFH1767G W
 16.7 Cubic Feet



- Frost Free
- Reversible Door
- Easy Set™ Control
- 4 Fixed Wire Shelves
- 1 Full-Access Sliding Storage Basket
- 5 Full-Width Fixed Door Bins
- Interior Light
- 2 Adjustable Leg Levelers
- Color-Coordinated Handle
- Automatic Door Closer

Dimensions:
 64-1/2" H x 32" W x 26-1/2" D
 (Cabinet depth includes door)

NEW





Frigidaire® FFU1764F W

16.7 Cubic Feet

- Frost Free
- Easy Set™ Control
- 4 Fixed Wire Shelves
- 1 Trivet
- 5 Full-Width Fixed Door Bins
- Lock with Pop-Out Key
- Interior Light
- 2 Adjustable Leg Levelers
- Color-Coordinated Handle
- Automatic Door Closer

Dimensions:

64-1/2" H x 32" W x 26-1/2" D
(Cabinet depth includes door)



Frigidaire® FFU1464F W

13.7 Cubic Feet

- Frost Free
- Easy Set™ Control
- 3 Fixed Wire Shelves
- 1 Trivet
- 5 Full-Width Fixed Door Bins
- Lock with Pop-Out Key
- Interior Light
- 2 Adjustable Leg Levelers
- Color-Coordinated Handle
- Automatic Door Closer

Dimensions:

59" H x 28" W x 28-1/2" D
(Cabinet depth includes door)



Frigidaire® FFU1152D W

11.2 Cubic Feet

- Frost Free
- Adjustable Temp Control
- 2 Fixed Wire Shelves
- 1 Trivet
- 4 Full-Width Fixed Door Bins
- Black Pocket Handle
- Black Base Grille Inserts
- 2 Adjustable Leg Levelers
- Automatic Door Closer

Dimensions:

54-1/2" H x 28" W x 26-1/2" D
(Cabinet depth includes door)

Frigidaire



Frigidaire®
FFU2124D W
20.6 Cubic Feet

- Manual Defrost
- Adjustable Temp Control
- 4 White Evaporator Shelves
- 1 Full-Access Sliding Storage Basket
- 6 Full-Width Fixed Door Bins
- Lock with Pop-Out Key
- Interior Light
- Defrost Drain
- 2 Adjustable Leg Levelers
- Color-Coordinated Handle
- Automatic Door Closer

Dimensions:
70" H x 32" W x 28-1/2" D
(Cabinet depth includes door)



Frigidaire®
FFU1724D W
17.1 Cubic Feet

- Manual Defrost
- Adjustable Temp Control
- 3 White Evaporator Shelves
- 1 Full-Access Sliding Storage Basket
- 5 Full-Width Fixed Door Bins
- Lock with Pop-Out Key
- Interior Light
- Defrost Drain
- 2 Adjustable Leg Levelers
- Color-Coordinated Handle
- Automatic Door Closer

Dimensions:
64-1/2" H x 32" W x 26-1/2" D
(Cabinet depth includes door)



Frigidaire® FFU1423D W

14.1 Cubic Feet

- Manual Defrost
- Adjustable Temp Control
- 3 White Evaporator Shelves
- 1 Full-Access Sliding Storage Basket
- 5 Full-Width Fixed Door Bins
- Lock with Pop-Out Key
- Interior Light
- Defrost Drain
- 2 Adjustable Leg Levelers
- Color-Coordinated Handle
- Automatic Door Closer

Dimensions:

59" H x 28" W x 28-1/2" D
(Cabinet depth includes door)



Frigidaire® FFU1212D W

11.6 Cubic Feet

- Manual Defrost
- Adjustable Temp Control
- 3 White Evaporator Shelves
- 4 Full-Width Fixed Door Bins
- Black Pocket Handle
- Black Base Grille Inserts
- Defrost Drain
- 2 Adjustable Leg Levelers
- Automatic Door Closer

Dimensions:

54-1/2" H x 28" W x 26-1/2" D
(Cabinet depth includes door)

Also Available:

FFU0912D W

8.7 Cubic Feet

(Same Features as FFU1212D W)

Dimensions:

51" H x 24" W x 26-1/2" D
(Cabinet depth includes door)

Frigidaire

Chest Freezer Features



Lock with Pop-Out Key
Key is automatically ejected upon locking for maximum security.



Temp Alarm and Power-On Light
Warning light and buzzer alert you if interior temperature of freezer becomes unsafe for proper food storage.



Defrost Water Drain
Drain makes for easy water run-off during defrosting.



StorMor™ Lift-Out Sliding Baskets
Convenient lift-out storage for easy access to most small frozen items or items that are most frequently accessed.



Food Organization System
Heavy-duty dividers allow you to organize food storage like never before. System includes and accommodates pre-printed storage labels.



Interior Light
Molded directly into freezer lid to provide maximum visibility.



Frigidaire®
AFFC1466D W
13.8 Cubic Feet

- Frost Free
- Adjustable Temp Control
- 2 Upper/2 Lower StorMor™ Lift-Out Storage Baskets
- Lock with Pop-Out Key
- Interior Light
- Power-On Light

Dimensions:
35" H x 48" W x 29-1/2" D
(Cabinet depth includes door)



Frigidaire



Frigidaire
GALLERY™

GLFC2528F W

24.9 Cubic Feet

- Manual Defrost
- Electronic Controls
- Adjustable Temp Control
- 3 StorMor™ Lift-Out Storage Baskets
- Food Organization System
- Lock with Pop-Out Key
- Interior Light
- Power-On Light
- Temp Alarm System
- Defrost Drain with Drain Pan
- Oil Cooler

Dimensions:

35" H x 73-1/4" W x 29-1/2" D
(Cabinet depth includes door)



Frigidaire
GALLERY™

GLFC2027F W

19.7 Cubic Feet

- Manual Defrost
- Adjustable Temp Control
- 3 StorMor™ Lift-Out Storage Baskets
- Food Organization System
- Lock with Pop-Out Key
- Interior Light
- Power-On Light
- Defrost Drain
- Oil Cooler

Dimensions:

35" H x 61-1/4" W x 29-1/2" D
(Cabinet depth includes door)





Frigidaire
GALLERY™

GLFC1526F W

14.8 Cubic Feet

- **Manual Defrost**
- Adjustable Temp Control
- 2 StorMor™ Lift-Out Storage Baskets
- Food Organization System
- Lock with Pop-Out Key
- Interior Light
- Power-On Light
- Defrost Drain

Dimensions:

35" H x 48" W x 29-1/2" D
(Cabinet depth includes door)



Frigidaire
GALLERY™

GLFC1326F W

12.8 Cubic Feet

- **Manual Defrost**
- Adjustable Temp Control
- 2 StorMor™ Lift-Out Storage Baskets
- Food Organization System
- Lock with Pop-Out Key
- Interior Light
- Power-On Light
- Defrost Drain

Dimensions:

35" H x 42-3/4" W x 29-1/2" D
(Cabinet depth includes door)



Frigidaire



Frigidaire® FFC0923D W

8.8 Cubic Feet

- Manual Defrost
- Adjustable Temp Control
- 2 StorMor™ Lift-Out Storage Baskets
- Power-On Light
- Defrost Drain

Dimensions:

34-1/4" H x 41" W x 23-1/4" D
(Cabinet depth includes door)



Frigidaire® FFC0723D W

7.2 Cubic Feet

- Manual Defrost
- Adjustable Temp Control
- 2 StorMor™ Lift-Out Storage Baskets
- Power-On Light
- Defrost Drain

Dimensions:

34-1/4" H x 35" W x 23-1/4" D
(Cabinet depth includes door)



Frigidaire®
FFC0723G B

7.2 Cubic Feet

- Manual Defrost
- Adjustable Temp Control
- 2 StorMor™ Lift-Out Storage Baskets
- Power-On Light
- Defrost Drain

Dimensions:

34-1/4" H x 35" W x 23-1/4" D
(Cabinet depth includes door)



Frigidaire®
FFC0522D W

5.0 Cubic Feet

- Manual Defrost
- Adjustable Temp Control
- 1 StorMor™ Lift-Out Storage Basket
- Power-On Light
- Defrost Drain

Dimensions:

34-1/4" H x 27" W x 23-1/4" D
(Cabinet depth includes door)

Frigidaire

Accessories



Ice Maker

Allows you to add ice-making capabilities to upright freezer model GLFU2067F and to all-freezer duo model PLFU1778E. **IM501**



Kitchen Care Kit

Everything you need to keep your kitchen appliances looking new including nonabrasive kitchen cleaners, microfiber sponges and scraper. **5304436288**



Stainless Steel Cleaning Polish and Conditioner

Polish your stainless steel to a darker shine while removing fingerprints and smudges quickly and easily. **5304436717**



16-Oz. Stainless Steel Appliance Cleaner

Preserve the look of your stainless steel appliances for years to come. Provides protection from fingerprints and smudges. **5304433275**



Stainless Steel Cleaning Polish and Conditioner Wipes

Handy Stainless Steel Wipes remove fingerprints and smudges while adding a layer of protection. Available in a ready-to-use canister. **5305512345**



Small StorMor™ Freezer Basket

Organize your small chest freezer with durable, plastic storage baskets. Designed for 5 to 9 cubic foot chest freezer, the baskets have a weight capacity of 14 lbs. **216848200**



Large StorMor™ Freezer Basket

Made specifically for chest freezers larger than 13 cubic feet. With a weight capacity of 21 lbs., you'll have plenty of capacity to organize small items. **216916200**

UPRIGHT FREEZERS

Models	GLFU2067FW	GLFU1767FW	GLFU1467FW	FFU2124DW	FFU2065FW	FFH1767GW	FFU1764FW
Series	Gallery	Gallery	Gallery	Frigidaire	Frigidaire	Frigidaire	Frigidaire
ENERGY STAR®							
Capacities							
Total Volume (Cu. Ft.)	20.3	16.7	13.7	20.6	20.3	16.7	16.7
Shelf Area (Sq. Ft.)	23.4	18.4	14.26	21.87	23.9	18.4	18.4
Features							
Defrost	Frost Free	Frost Free	Frost Free	Manual	Frost Free	Frost Free	Frost Free
Adjustable Temp Control	Precision Set™	Precision Set™	Precision Set™	-	Easy Set™	Easy Set™	Easy Set™
Display Mode	-	-	-	-	-	-	-
Extreme Freeze	-	-	-	-	-	-	-
Temp Alarm System	-	-	-	-	-	-	-
Door Ajar Alarm	-	-	-	-	-	-	-
System Error Alarm	-	-	-	-	-	-	-
Interior Light	-	-	-	-	-	-	-
Power-On Light	Electronic Bezel	-	-	-	-	-	-
Interior Shelves	4 Glass (2 Adjustable)	4 Glass (2 Adjustable)	3 Glass	4 Fixed White	5 Wire (1 Adjustable)	4 Fixed Wire	4 Fixed Wire
Trivet	-	-	-	-	-	-	-
Basket(s)	2 Sliding	2 Sliding	1 Sliding	1 Sliding	1 Sliding	1 Sliding	-
Basket Dividers	2	2	1	-	-	-	-
Small Item Shelf	-	-	-	-	-	-	-
Fixed Door Bin(s)	4	3	4	-	-	-	-
Standard Door Bin(s)	-	-	-	6	5	5	5
Tilt-Out Wire Door Bin(s)	2	2	1	-	1	-	-
Defrost Drain	-	-	-	-	-	-	-
Door Handle	Powder Coated	Powder Coated	Powder Coated	Reach Through	Powder Coated	Powder Coated	Powder Coated
Reversible Door	-	-	-	-	-	-	-
Lock with Pop-Out Key	-	-	-	-	-	-	-
Ice Maker-Ready	-	-	-	-	-	-	-
Color / UPC (0-12505-)							
White (W)	22383-9	22382-2	22381-5	22273-3	22460-7	22531-4	22388-4
Dimensions / Specifications							
A - Height	70"	64-1/2"	59"	70"	70"	64-1/2"	64-1/2"
B - Width	32"	32"	28"	32"	32"	32"	32"
C - Depth	28-1/2"	26-1/2"	28-1/2"	28-1/2"	28-1/2"	26-1/2"	26-1/2"
D - Depth with Door Open 90°	59-1/8"	57-1/8"	55-1/8"	59-1/8"	59-1/8"	57-1/8"	57-1/8"
Shipping Weight (Approx.)	235 Lbs.	214 Lbs.	186 Lbs.	224 Lbs.	235 Lbs.	214 Lbs.	214 Lbs.
Carton Dimensions (WxHxD)	35"x73-5/8" x33-1/2"	35"x67-3/4" x31-1/2"	31"x62-1/2" x33-1/2"	35"x73-5/8" x33-1/2"	35"x73-5/8" x33-1/2"	35"x67-3/4" x31-1/2"	35"x67-3/4" x31-1/2"
Annual Energy (kWH)	763	682	621	527	763	615	682
Annual Energy Cost (.0906/kWH)	\$69	\$62	\$56	\$48	\$69	\$56	\$62
CSA Rating	Commercial	Commercial	Commercial	Commercial	Commercial	Commercial	Commercial

UPRIGHT FREEZER INSTALLATION

The following dimension and cutout information is for planning purposes only. For complete installation details consult manual packed with product, or download manual at Customer Service, online at frigidaire.com.

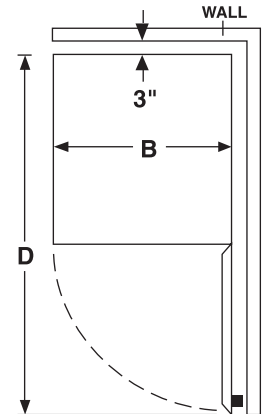
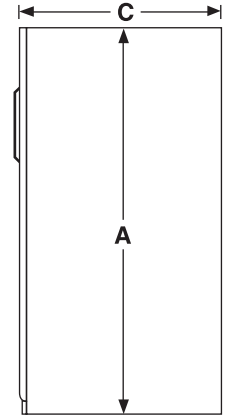

Allow sufficient clearance on hinge side of freezer when installing next to a wall where handle may make contact.

Refer to specification chart for variable dimensions.

Models	FFU1724DW	FFU1464FW	FFU1423DW	FFU1212DW	FFU1152DW	FFU0912DW
Series	Frigidaire	Frigidaire	Frigidaire	Frigidaire	Frigidaire	Frigidaire
Capacities						
Total Volume (Cu. Ft.)	17.1	13.7	14.1	11.6	11.2	8.7
Shelf Area (Sq. Ft.)	16.2	14.26	14.97	13	9.75	10.7
Features						
Defrost	Manual	Frost Free	Manual	Manual	Frost Free	Manual
Adjustable Temp Control	-	Easy Set™	-	-	-	-
Interior Light	-	-	-	-	-	-
Interior Shelves	3 Fixed White	3 Fixed Wire	3 Fixed White	3 Fixed White	2 Fixed Wire	3 Fixed White
Trivet	-	-	-	-	-	-
Basket(s)	1 Sliding	-	1 Sliding	-	-	-
Standard Door Bins	5	5	5	4	4	4
Defrost Drain	-	-	-	-	-	-
Door Handle	Reach Through	Powder Coated	Reach Through	Pocket	Pocket	Pocket
Lock with Pop-Out Key	-	-	-	-	-	-
Color / UPC (0-12505-)						
White (W)	22284-9	22387-7	22272-6	22299-3	22271-9	22308-2
Dimensions / Specifications						
A - Height	64-1/2"	59"	59"	54-1/2"	54-1/2"	51"
B - Width	32"	28"	28"	28"	28"	24"
C - Depth	26-1/2"	28-1/2"	28-1/2"	26-1/2"	26-1/2"	26-1/2"
D - Depth with Door Open 90°	57-1/8"	55-1/8"	55-1/8"	53-1/8"	53-1/8"	49-1/8"
Shipping Weight (Approx.)	200 Lbs.	186 Lbs.	178 Lbs.	164 Lbs.	178 Lbs.	144 Lbs.
Carton Dimensions (WxHxD)	35"x67-3/4" x31-1/2"	31"x62-1/2" x33-1/2"	31"x62-1/2" x33-1/2"	31"x58" x31-1/2"	31"x58" x31-1/2"	27"x54" x31-1/2"
Annual Energy (kWH)	480	621	442	409	564	372
Annual Energy Cost (.0906/kWH)	\$43	\$56	\$40	\$37	\$51	\$34
CSA Rating	Commercial	Commercial	Commercial	Household	Commercial	Household



White

CHEST FREEZERS

Models	GLFC2528FW	GLFC2027FW	GLFC1526FW	GLFC1326FW
Series	Gallery	Gallery	Gallery	Gallery
Capacities				
Total Volume (Cu. Ft.)	24.9	19.7	14.8	12.8
Features				
Defrost	Manual	Manual	Manual	Manual
Adjustable Temp Control	•	•	•	•
Power-On Light	•	•	•	•
Interior Light	•	•	•	•
Lift-Out Storage Baskets	3	3	2	2
Food Organization System	•	•	•	•
Defrost Drain	•	•	•	•
Lid Handle	•	•	•	•
Lock with Pop-Out Key	•	•	•	•
Temp Alarm System	•	•	•	•
Oil Cooler	•	•	•	•
Color / UPC (0-12505-)				
White (W)	22378-5	22377-8	22376-1	22375-4
Black (B)				
Dimensions / Specifications				
A - Height	35"	35"	35"	35"
B - Height with Lid Open 90°	60-13/16"	60-13/16"	60-13/16"	60-13/16"
C - Width	73-1/4"	61-1/4"	48"	42-3/4"
D - Depth	29-1/2"	29-1/2"	29-1/2"	29-1/2"
Shipping Weight (Approx.)	224 Lbs.	195 Lbs.	161 Lbs.	151 Lbs.
Carton Dimensions (WxHxD)	76-1/4" x 36-1/2" x 33-1/4"	64-1/4" x 36-1/2" x 33-1/4"	51-1/4" x 36-1/2" x 33-1/4"	46" x 36-1/2" x 33-1/4"
Annual Energy (kWH)	569	480	397	362
Annual Energy Cost (.0906/kWH)	\$52	\$43	\$36	\$33
CSA Rating	Commercial	Commercial	Commercial	Commercial

Models	AFFC1466DW	FFC0923DW	FFC0723DW	FFC0723GB	FFC0522DW
Series	Frigidaire	Frigidaire	Frigidaire	Frigidaire	Frigidaire
Capacities					
Total Volume (Cu. Ft.)	13.8	8.8	7.2	7.2	5.0
Features					
Defrost	Frost Free	Manual	Manual	Manual	Manual
Adjustable Temp Control	•	•	•	•	•
Power-On Light	•	•	•	•	•
Interior Light	•	•	•	•	•
Lift-Out Storage Baskets	2 Upper / 2 Lower	2	2	2	1
Food Organization System	•	•	•	•	•
Defrost Drain	•	•	•	•	•
Lid Handle	•	•	•	•	•
Lock with Pop-Out Key	•	•	•	•	•
Color / UPC (0-12505-)					
White (W)	22306-8	22270-2	22269-6		22314-3
Black (B)				22527-7	
Dimensions / Specifications					
A - Height	35"	34-1/4"	34-1/4"	34-1/4"	34-1/4"
B - Height with Lid Open 90°	60-13/16"	55-5/16"	55-5/16"	55-5/16"	55-5/16"
C - Width	48"	41"	35"	35"	27"
D - Depth	29-1/2"	23-1/4"	23-1/4"	23-1/4"	23-1/4"
Shipping Weight (Approx.)	161 Lbs.	127 Lbs.	115 Lbs.	115 Lbs.	99 Lbs.
Carton Dimensions (WxHxD)	51-1/4" x 36-1/2" x 33-1/4"	43-1/2" x 36-1/2" x 26-3/4"	37-3/4" x 36-1/2" x 26-3/4"	37-3/4" x 36-1/2" x 26-3/4"	29-3/4" x 36-1/2" x 26-3/4"
Annual Energy (kWH)	539	294	279	279	242
Annual Energy Cost (.0906/kWH)	\$49	\$27	\$25	\$25	\$22
CSA Rating	Commercial	Commercial	Commercial	Commercial	Commercial



CHEST FREEZER INSTALLATION

The following dimension and cutout information is for planning purposes only. For complete installation details consult manual packed with product, or download manual at Customer Service, online at frigidaire.com.

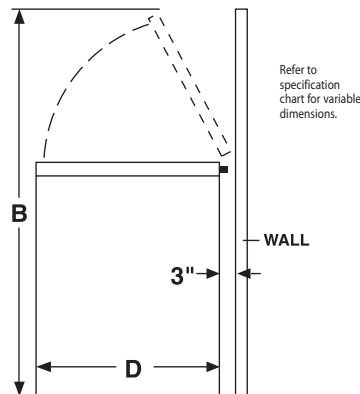
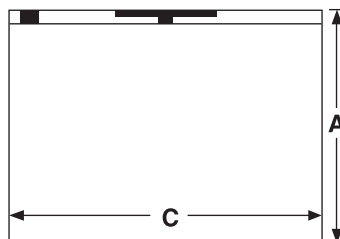

ALL-FREEZER/ALL-REFRIGERATOR DUO

34 Cu. Ft. Model	PLFU1778ES	PLRU1778ES
Series	Professional	Professional
Capacities		
Total Capacity (Cu. Ft.)	33.7	33.7
Total Shelf Area (Sq. Ft.)	34.8	34.8
Volume (Cu. Ft.)	16.8	16.9
Shelf Area (Sq. Ft.)	17.04	17.74
Exterior Conveniences		
Door Handle	UltraPro Stainless Steel	UltraPro Stainless Steel
Interior Conveniences		
Mid-Level Lighting (2 - 40W 4" Long Tubular per Unit)	•	•
Cantilever Glass Shelves	2 FW	3 FW
Fixed Glass Shelves		1 FW
Sliding Glass Shelves	1 FW	
Door Bins	2 Tilt-Out Wire / 3 FW Fixed White	4 Clear Adjustable / 1 FW White Gallon
Dairy Door		1 Clear
Deli Drawer		1 Clear
Crispers/Humidity Controls		2 Clear / 1
Full Access Sliding Baskets	2 FW	
Color/UPC (0-12505)		
Stainless Steel (S)	22355-6	22356-3
Specifications		
A-Height	64-1/2"	64-1/2"
B-Width (Single/Duo)	32"/64-1/4"	32"/64-1/4"
C-Depth (including Door)	26-1/2"	26-1/2"
D-Depth (with Door Open 90°)	57-1/4"	57-1/4"
Product Weight	207 Lbs.	205 Lbs.
Shipping Weight (Approx.)	229 Lbs.	227 Lbs.
Optional Accessories		
Duo Trim Kit	DUOTRIMKIT	DUOTRIMKIT
Single Unit Trim Kit	ALLFRZKIT	ALLREFKIT
Ice Maker	IMS01	



Stainless Steel

ALL-FREEZER/ALL-REFRIGERATOR DUO INSTALLATION

The following dimension and cutout information is for planning purposes only. For complete installation details consult manual packed with product, or download manual at Customer Service, online at frigidaire.com.

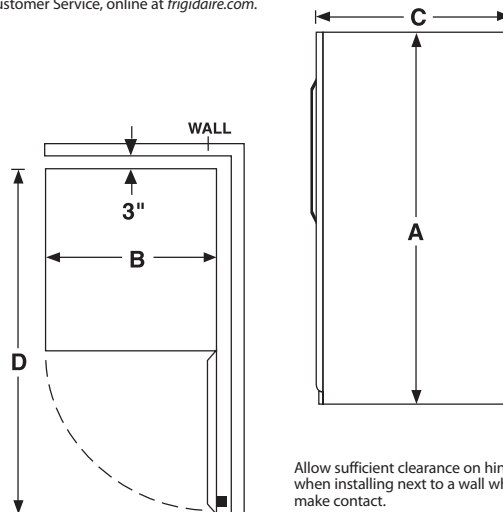

Allow sufficient clearance on hinge side of unit when installing next to a wall where handle may make contact.

CUTOUT DIMENSIONS

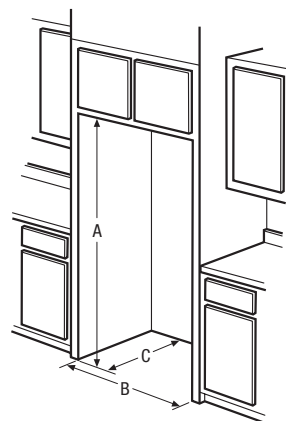

Single Unit Cutout Dimensions

Without Trim Kit	With Trim Kit
(A) 66"	(A) 75"
(B) 33"	(B) 33"
(C) 25 1/4" min.	(C) 25 1/4" min.

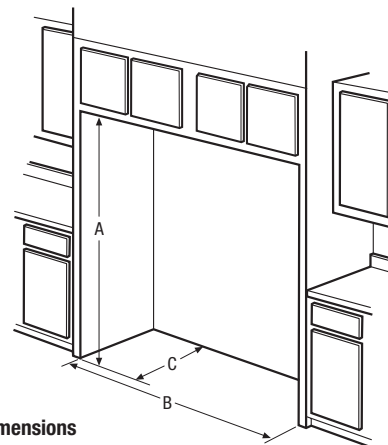

Dual Unit Cutout Dimensions

Without Trim Kit	With Trim Kit
(A) 66"	(A) 75"
(B) 66"	(B) 66"
(C) 25 1/4" min.	(C) 25 1/4" min.

TRIM KITS

The following information provides cutout dimensions for the single and duo trim kits.

Appliances Dimensions

	Single	Duo
(A)	64-1/2"	64-1/2"
(B)	32"	64-1/4"
(C)	26-1/2"	26-1/2"
(D)	34-1/2"	66-3/4"

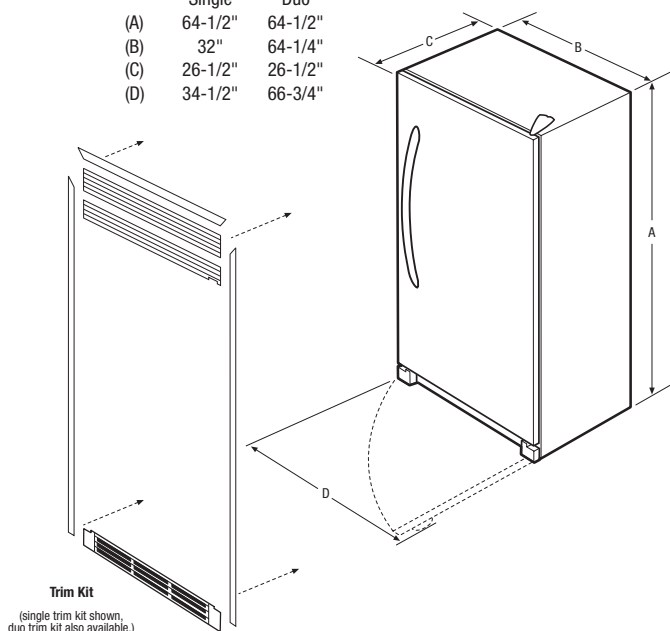

Trim Kit (single trim kit shown, duo trim kit also available.)



LIMITED ONE-YEAR WARRANTY

This warranty does not cover the following:

- Products with original serial numbers that have been removed, altered or cannot be readily determined.
- Product that has been transferred from its original owner to another party or removed outside the USA or Canada.
- Rust on the interior or exterior of the unit.
- Products purchased "as-is" are not covered by this warranty.
- Food loss due to any refrigerator or freezer failures.
- Products used in a commercial setting.
- Service calls which do not involve malfunction or defects in materials or workmanship, or for appliances not in ordinary household use or used other than in accordance with the provided instructions.
- Service calls to correct the installation of your appliance or to instruct you how to use your appliance.
- Expenses for making the appliance accessible for servicing, such as removal of trim, cupboards, shelves, etc., which are not a part of the appliance when it is shipped from the factory.
- Service calls to repair or replace appliance light bulbs, air filters, water filters, other consumables, or knobs, handles, or other cosmetic parts.
- Surcharges including, but not limited to, any after hour, weekend, or holiday service calls, tolls, ferry trip charges, or mileage expense for service calls to remote areas, including the state of Alaska.
- Damages to the finish of appliance or home incurred during installation, including but not limited to floors, cabinets, walls, etc.
- Damages caused by: services performed by unauthorized service companies; use of parts other than genuine Electrolux parts or parts obtained from persons other than authorized service companies; or external causes such as abuse, misuse, inadequate power supply, accidents, fires, or acts of God.

DISCLAIMER OF IMPLIED WARRANTIES; LIMITATION OF REMEDIES

Customer's sole and exclusive remedy under this limited warranty shall be product repair or replacement as provided herein. Claims based on implied warranties, including warranties of merchantability or fitness for a particular purpose, are limited to one year or the shortest period allowed by law, but not less than one year. Electrolux shall not be liable for consequential or incidental damages such as property damage and incidental expenses resulting from any breach of this written limited warranty or any implied warranty. Some states and provinces do not allow the exclusion or limitation of incidental or consequential damages, or limitations on the duration of implied warranties, so these limitations or exclusions may not apply to you. This written warranty gives you specific legal rights. You may also have other rights that vary from state to state.

IF YOU NEED SERVICE

Keep your receipt, delivery slip, or some other appropriate payment record to establish the warranty period should service be required. If service is performed, it is in your best interest to obtain and keep all receipts. Service under this warranty must be obtained by contacting Electrolux at the addresses or phone numbers below. Your appliance is covered by a one year limited warranty. For one year from your original date of purchase, Electrolux will pay all costs for repairing or replacing any parts of this appliance that prove to be defective in materials or workmanship when such appliance is installed, used, and maintained in accordance with the provided instructions. This warranty only applies in the USA and Canada. In the USA, your appliance is warranted by Electrolux Major Appliances North America, a division of Electrolux Home Products, Inc. In Canada, your appliance is warranted by Electrolux Canada Corp. Electrolux authorizes no person to change or add to any obligations under this warranty. Obligations for service and parts under this warranty must be performed by Electrolux or an authorized service company. Product features or specifications as described or illustrated are subject to change without notice.

USA

Electrolux Major Appliances, North America

250 Bobby Jones Expressway
Martinez, GA 30907
1-800-FRIGIDAIRE
frigidaire.com

CANADA

Electrolux Canada Corporation

5855 Terry Fox Way
Mississauga, ON L5V 3E4
1-800-668-4606



Every Frigidaire® appliance is backed by the global strength of the Electrolux Group, the world's largest manufacturer of kitchen and cleaning appliances.