

NOTES:

1. TO INSPECT ASSEMBLY, FOLLOW FIRST ARTICLE AND IN PROCESS INSPECTION SHEET.

**BILL OF MATERIAL (CURRENT LEVEL)**

ITEM	PT/ASSY	DESCRIPTION	TYPE	QTY.
1	7-732	CORNER BASKET	PART	1
2	55CC	BASKET MOUNTING	ASSEMBLY	2
3	1-206	HARDWARE PACK	ASSEMBLY	2

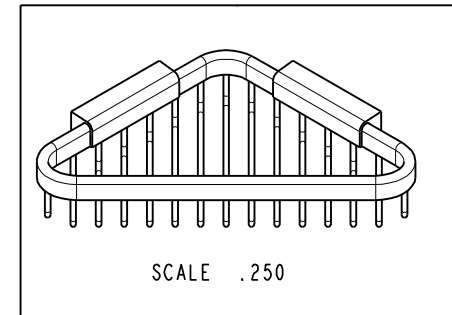
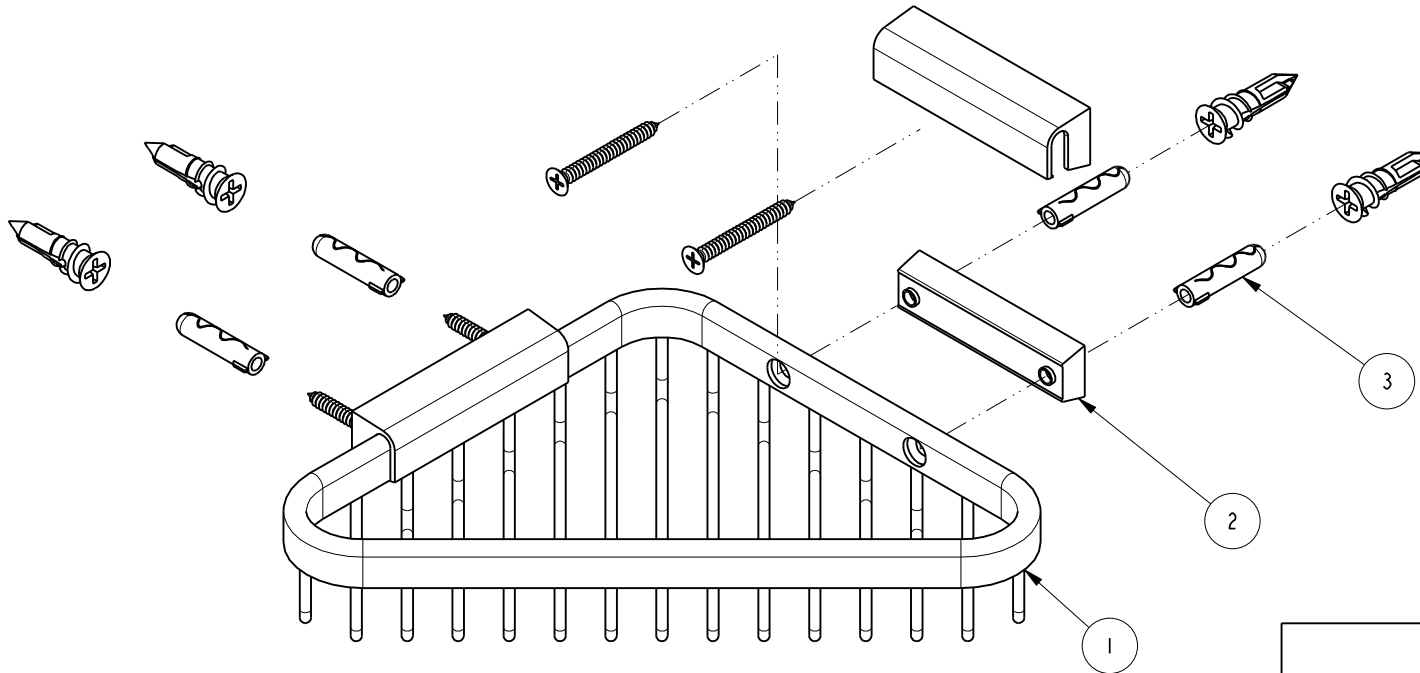

ZONE	REV	DESCRIPTION	DATE	APPROVED
-	B	EN-4422	12/21/21	R.S.
-	A	EN-3531	02/28/18	J.M.

COPYRIGHT 2005 BRASSTECH, INC. THESE DRAWINGS AND THE DESIGNS DEPICTED HEREIN ARE THE PROPRIETARY PROPERTY OF BRASSTECH. ANY USE OR REPRODUCTION IS SUBJECT TO THE EXPRESS APPROVAL OF BRASSTECH. UNAUTHORIZED USE IS STRICTLY PROHIBITED. ALL RIGHTS RESERVED.

TESTING	ASSEMBLY	PLATING	POLISHING	MACHINING	TOOLING FIXTURE #	APPLICATION
-	-	-	-	-	-	REMOVE ALL BURRS AND SHARP EDGES

UNITS ARE: INCHES [MM]		
TOLERANCES ARE:		
FRACTIONS DECIMALS	ANGLES	
±1/16"	±1°	
.X ±.1 [2.5]		
.XX ±.06 [1.5]		
(X.XXX) DENOTES CRITICAL DIMS.		
ALL THREADS ARE CRITICAL		
DRAWN	JINSON	02/28/18
CHECKED	J.M.	02/28/18
APPROVED	J.M.	02/28/18

**BRASSTECH** 2001 CARNEGIE AVE. SANTA ANA, CA 92705 (949) 417-5207  
INCORPORATED

**6" CORNER BASKET**

DWG NO. **553G** REV **B**

SCALE .500 REF. - SHEET 1 OF 2

