

5-1/4" AMERICAN-DARLING® B-84-B-5 PARTS LIST



Part No.	Qty.	Description	Material
84-1	1	Operating Nut	Bronze
84-2-1	2	Cover O-ring	Buna N
84-2-2	2	Housing O-ring	Buna N
84-4-4	1	Thrust Washer	Nylatron
84-5-3	1	Pipe Plug	Stainless Steel
84-7-7	1	Weather Cover	Gray Iron
84-9	1	Housing Cover	Gray Iron
84-11-2	4	Housing Cover Cap Screw	Plated Steel
84-13	1	Housing Cover Gasket	Fiber
84-14	1	Housing Gasket	Composition Rubber
84-15	1	Housing	Ductile Iron
84-16	6	Housing Bolt and Nut	Plated Steel
84-18-60	1	Upper Barrel	Ductile Iron
84-19-SR	1	Lower Barrel	Ductile Iron
84-20-60	2	Hose Nozzle	Bronze
84-20-61	2	Hose Nozzle O-ring Seal	Buna N
84-20-62	2	Hose Nozzle Retainer	Ductile Iron
84-20-63	2	Hose Nozzle Retainer Washer	Teflon
84-21	2	Hose Cap	See Note 8
84-22	2	Hose Cap Gasket	Rubber
84-23-1	1 Per Nozzle	Hose Cap Chain	Steel
84-23-2	1 Per Nozzle	S Hook	Steel
84-23-18	1 Per Nozzle	Pumper Cap Chain	Steel
84-25-60	1 or 0	Pumper Nozzle	Bronze
84-25-61	1 Per Nozzle	Pumper Nozzle O-ring Seal	Buna N
84-25-62	1 Per Nozzle	Pumper Nozzle Retainer	Ductile Iron
84-25-63	1 Per Nozzle	Pumper Nozzle Retainer Washer	Teflon
84-26	1 Per Nozzle	Pumper Cap	See Note 8
84-27	1 Per Nozzle	Pumper Cap Gasket	Rubber
84-29-13	1	Barrel Flange	Ductile Iron
84-29-13B	1	Base Flange	Ductile Iron
84-29-14	2	Snap Ring	Stainless Steel
84-29-30	1	Rod Coupling	Epoxy Coated Gray Iron
84-29-31	2	Rod Coupling Pin and Clip Pin	Stainless Steel
84-29-45	1	Breakable Flange	Gray Iron
84-30-03	1	Spring	Stainless Steel
84-30-04	1	Spring Plate	Stainless Steel
84-30-06	1	Travel Stop Nut	Bronze
84-30-07	1	Spring Plate Pin	Stainless Steel
84-30-11	1	Upper Rod	Steel
84-30-12	1	Lower Rod	Steel
84-31	1	Drain Lever	Bronze
84-35-02	1	Hydrant Seat	Bronze
84-36-1	2	Hydrant Seat O-ring	Buna N

5-1/4" AMERICAN-DARLING® B-84-B-5 REPAIR INSTRUCTIONS



Disassembling the Hydrant

[View Video](#)

WARNING: Special care should be taken in the installation, inspection and repair of pressure containing devices such as valves and hydrants. **FAILURE TO FOLLOW PROPER PRACTICE AND GUIDELINES CAN RESULT IN SERIOUS INJURY OR DEATH.** High pressure and water hammer, due to rapid opening or closing of a hydrant or valve, can also cause major damage to the hydrant, valve, water main, fire hose, or other attached equipment.

Removing Internal Parts

One person with hand tools and a lightweight seat wrench can quickly remove all the working parts, including hydrant valve, drain lever and hydrant seat. To repair, it is not necessary to excavate American-Darling hydrants; merely remove the internal parts.

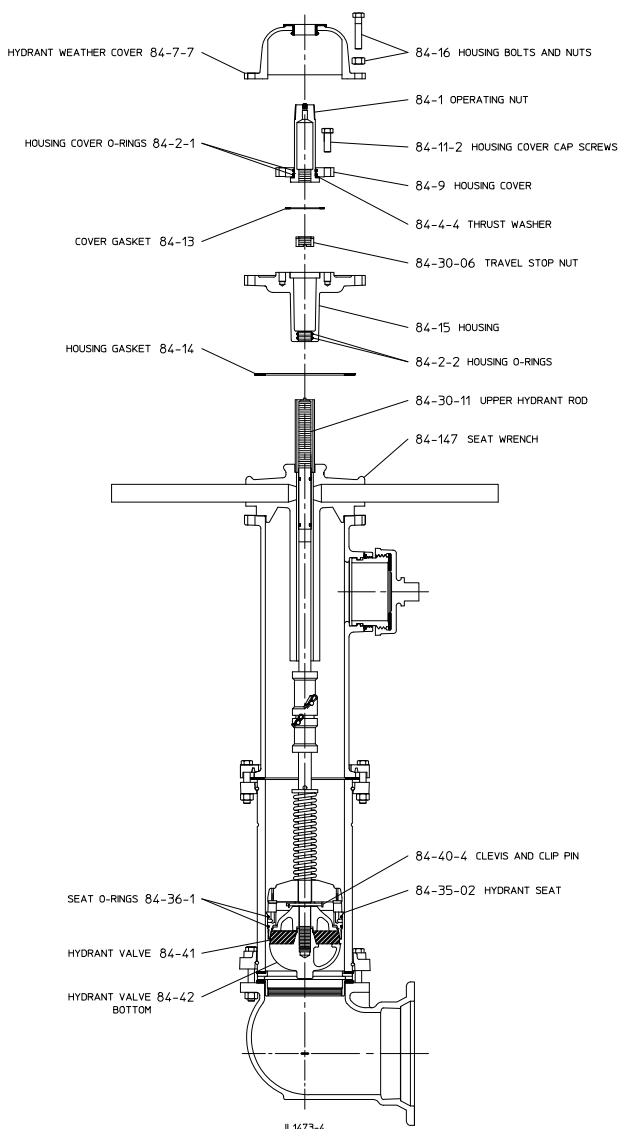

Directions for Removing Internal Parts of 5-1/4" American-Darling B-84-B-5 Hydrants

1. Shut off water line leading to hydrant making sure the hydrant is not under pressure. **FAILURE TO FOLLOW PROPER PRACTICE AND GUIDELINES CAN RESULT IN SERIOUS INJURY OR DEATH.**
2. Partially open hydrant valve to relieve trapped pressure.
3. Standing to the side of the hydrant and away from the direction of the hydrant cap(s), loosen one of the hose caps to relieve any pressure that may be present in the hydrant barrel. Close hydrant valve. From full open to full close takes approximately 17 1/2 turns.
4. Remove hydrant weather cover (84-7-7) with weather shield by removing two bolts and nuts (84-16).
5. Remove the four housing cover cap screws (84-11-2) on housing cover (84-9).
6. Unscrew and remove operating nut (84-1) from upper hydrant rod (84-30-11) together with housing cover (84-9) and thrust washer (84-4-4).
7. Use top of seat wrench to unscrew and remove travel stop nut (84-30-06).
8. Remove remaining housing bolts (84-16) then lift out housing (84-15). Inspect O-rings and replace if necessary. Special care must be taken to avoid damaging O-rings (84-2-2).
9. Place seat wrench over upper hydrant rod (84-30-11) and turn to the left (counterclockwise) to unscrew bronze hydrant seat (84-35-02) and lift out hydrant rod with completely assembled internal working parts attached, including hydrant seat, hydrant valve, drain lever and seat O-rings.

NOTE: When a supply of gaskets and O-rings are available, always install new ones when reassembling the hydrant. Clean dirt from O-ring grooves.



Reassembling the Hydrant

[View Video](#)

WARNING: Special care should be taken in the installation, inspection and repair of pressure containing devices such as valves and hydrants. **FAILURE TO FOLLOW PROPER PRACTICE AND GUIDELINES CAN RESULT IN SERIOUS INJURY OR DEATH.** High pressure and water hammer, due to rapid opening or closing of a hydrant or valve, can also cause major damage to the hydrant, valve, water main, fire hose, or other attached equipment.

1. On B-84-B hydrants manufactured prior to 1997 when the hydrant valve is replaced, use a locking compound to secure the valve ball assembly. On B-84-B hydrants manufactured after 1997, pin the valve ball assembly in place with the clevis and clip pin (84-40-4). Tighten lower valve bottom (84-42) to 145 ft-lbs. of torque. Advance slot in the valve top (84-40) to next pin location.
2. Thread the valve assembly (parts 84-40, 84-41, 84-42) to the lower hydrant rod. Grease the seat O-rings (84-36-1) and lower the parts through the hydrant barrel.
3. When the assembly has made contact with the drain ring (84-37), push the assembly straight down. To avoid cross threading, turn the seat wrench counterclockwise until an ajar is felt. This ajar indicates that the thread starts are properly aligned.
4. Turn the seat wrench clockwise approximately seven turns until it is tight. Pull upward on the rod to ensure it is securely fastened to the drain ring (84-37). Replace the housing gasket (84-14).
5. Grease the threads on the upper hydrant rod (84-30-11) and the O-rings (84-2-2) in the housing.
6. Slip the housing (84-15) over the rod. Note: Special care should be taken to avoid damaging housing O-rings. Thread the travel stop nut (84-30-06) onto the upper rod until contact is made with the brass rod sleeve. Care should be taken to not over tighten the travel stop nut or damage can occur to the sleeve.
7. Put the cover gasket (84-13) in place and then thread the bronze operating nut (84-1) onto the rod.
8. Bolt up the housing (84-15) using approximately 60 ft-lbs of torque.
9. Tighten the operating nut with the operating wrench and put the cover cap screws (84-11-2) in place. Then replace the weather cover (84-7-7) and bolt it up properly using approximately 60 ft-lbs of torque.
10. Carefully pressurize the hydrant and check for visual leaks.

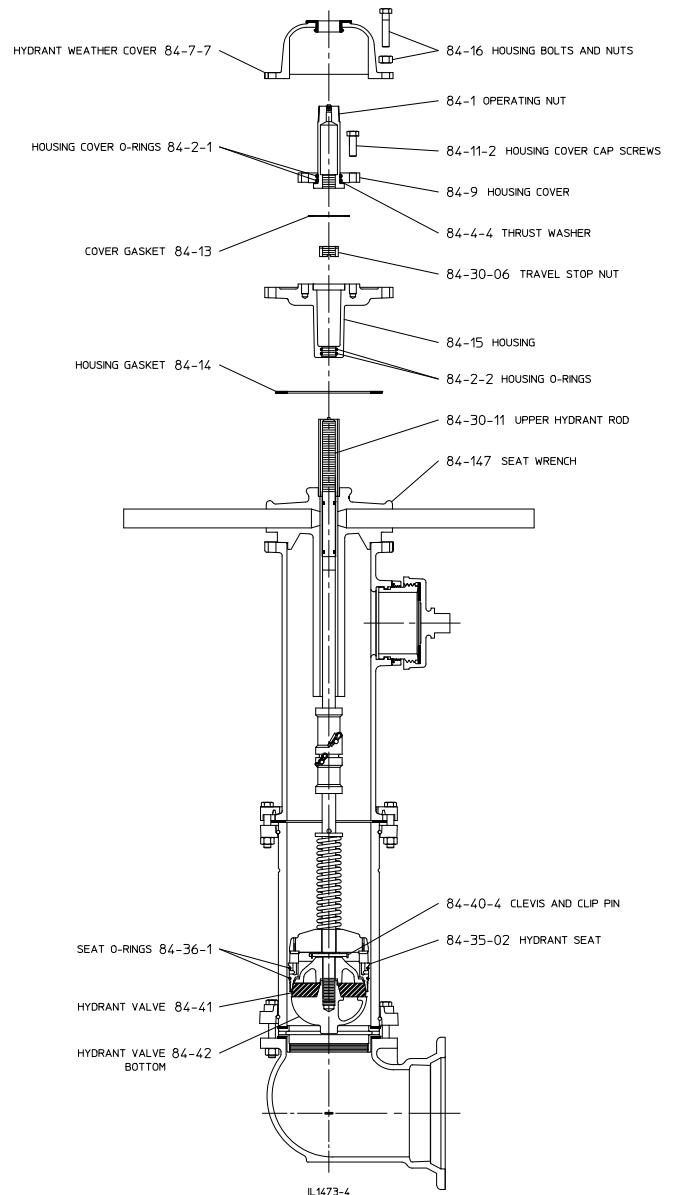

Note: Where grease is specified, use an AMERICAN Flow Control recommended food grade grease.