

TECHNICAL GUIDE

MODELS: MA

MODULAR AIR HANDLERS FOR USE WITH SPLIT SYSTEM COOLING & HEAT PUMP

600 - 2000 CFM BLOWERS

2 - 5 TON COILS

OPTIONAL 1 & 3 ϕ ELECTRIC HEATERS

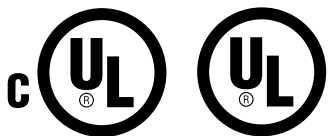

Due to continuous product improvement, specifications are subject to change without notice.

Visit us on the web at www.york.com

Additional rating information can be found at www.ahridirectory.org

DESCRIPTION

This unique modular system allows the flexibility to handle any application. These versatile coils and blowers may be used for upflow, down-flow, or horizontal left or right applications. They may be combined to function as a cooling only unit or with a heat pump including electric heat for 1 and 3 phase applications. The blower and electric heater could be used as stand alone electric furnaces.

FEATURES

Blowers - Models to match any air flow or voltage requirement. The compact size allows easy installation. Blowers are sized to deliver design air quantity both efficiently and quietly. The direct-drive, multi-speed blower motors provide a selection of air quantities to match any application. All models include a one-minute blower off delay as standard to enhance system efficiency ratings. The durable, pre-painted steel protects the unit against rust and corrosion. All models have 1 inch foil face fiber glass insulation, providing a thermal insulation value of R-4.2.

Coils - Staggered rows of rifled copper tubes are mechanically expanded into enhanced surface aluminum fins to provide high heat transfer and long-lasting quality. The MC multi-position coils may be used for upflow, downflow, and horizontal left or right applications. Coil cabinets are insulated with 3/4" foil face insulation to prevent sweating.

Thermal Expansion Valves - Available with R-22 or R-410A factory installed TXV's. Air Handlers maybe ordered as "Flex-coil" unit without a factory installed mertering device. Flex-coil models allow for field installed R-22 or R-410A TXV's for added flexibility to meet refrigerant system choice.

Electric Heaters - Both single and three phase electric heater models are available to match any requirement. All heaters include nickel-chromium elements with a 5-year limited warranty on 1 \emptyset heating elements and 1 year limited warranty on 3 \emptyset heating elements. Sequential operation is provided to control heaters in all models. Circuit breakers are used in 208/230 volt, single-phase heaters of 15 KW and larger.

Models equipped with circuit breakers may be altered in the field to use multi-source power supply. Over-temperature limit switches provide protection from airflow loss with fusible link backup protection.

NOTE: No heat kits are available for 115 Volt models.

Accessories - A full line of matching accessories available for use with the blower and coils to allow any type application.

LIMITATIONS

These units must be wired and installed in accordance with all national and local safety codes.

Voltage limits are as follows:

BLOWER VOLTAGE	VOLTAGE CODE	NORMAL OPERATING VOLTAGE RANGE*
115-1-60	11	104-126
208/230-1-60	21	187-253
460-3-60	41	432-504

* Rated in accordance with ARI Standard 110, utilization range "A".

Air flow must be within the minimum and maximum limits approved for electric heat, evaporator coils and outdoor units.

DIMENSIONS - (BLOWER WITH MC COILS)

NOTE: Power wiring may be brought into the unit through one of the knockouts in either the top or the left side panel. Multiple knockouts are provided to accommodate all of the electric heat and transformer accessories that are available. Use the knockouts that provide the best wire routing for the accessory being used.

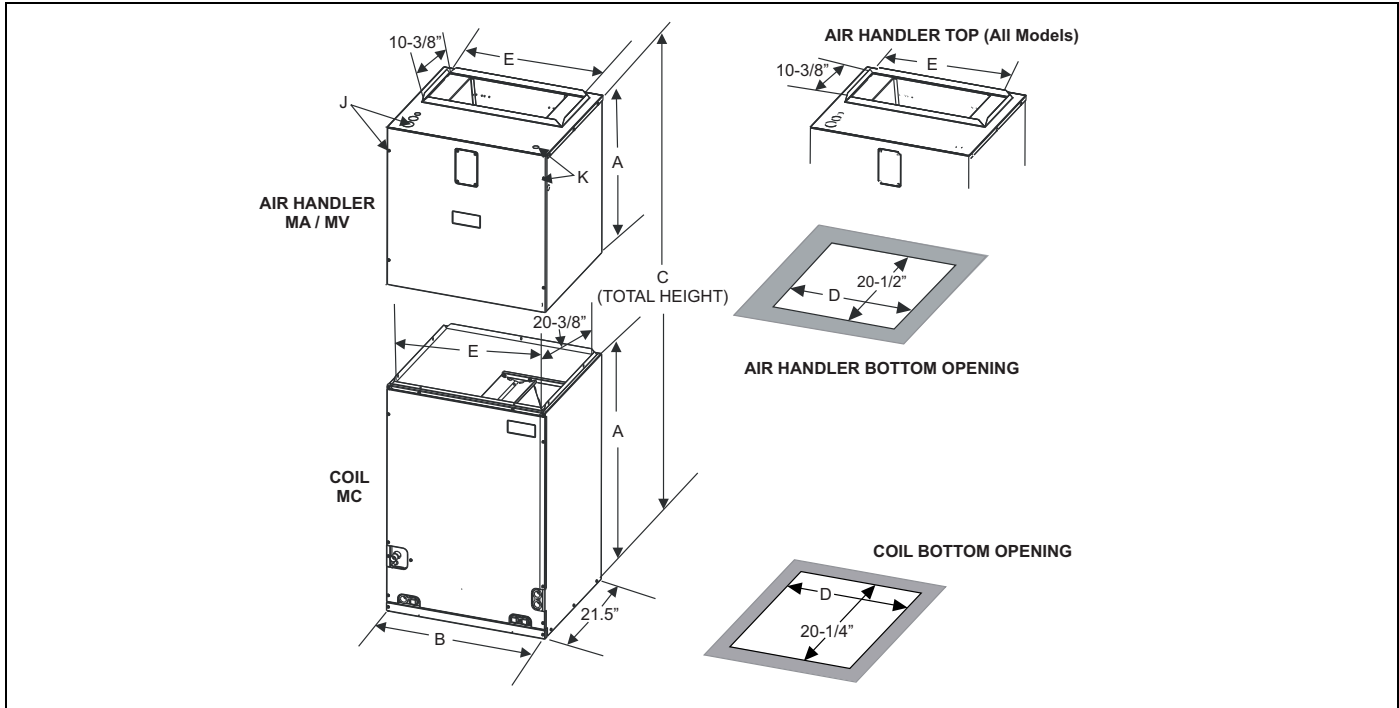

DIMENSIONS

Models	Dimensions					Wiring K.O.'s ¹		Refrigerant Connections	
	A	B	C	D	E	J	K	Line Size	
	Height	Width	Total Height			Power	Control	Liquid	Vapor
MA08B	25	17-1/2	47 to 57 Depending on combination	16-1/2	14-19/32	7/8 (1/2), 1-3/8(1) 1-23/32, (1-1/4) 1-31/32, (1-1/2)	7/8 (1/2)	-	-
MA12B ²	25	17-1/2		16-1/2	14-19/32			-	-
MA14D	25	24-1/2		23-1/2	21-19/32			-	-
MA16C ²	25	21		20	18-3/32			-	-
MA20D ²	25	24-1/2		23-1/2	21-19/32			-	-
MC18B2AH1	22	17.5	47 to 57 Depending on combination	16.5	16 3/8	-	-	3/8	3/4
MC18B3XH1	22	17.5		16.5	16 3/8	-	-	3/8	3/4
MC18B4EH1	22	17.5		16.5	16 3/8	-	-	3/8	3/4
MC24B2AH1	26.5	17.5	47 to 57 Depending on combination	16.5	16 3/8	-	-	3/8	3/4
MC24B3XH1	26.5	17.5		16.5	16 3/8	-	-	3/8	3/4
MC24B4FH1	26.5	17.5		16.5	16 3/8	-	-	3/8	3/4
MC30B2AH1	26.5	17.5	47 to 57 Depending on combination	16.5	16 3/8	-	-	3/8	3/4
MC30B3XH1	26.5	17.5		16.5	16 3/8	-	-	3/8	3/4
MC30B4EH1	26.5	17.5		16.5	16 3/8	-	-	3/8	3/4
MC30B4FH1	26.5	17.5		16.5	16 3/8	-	-	3/8	3/4
MC35B2AH1	22	17.5	47 to 57 Depending on combination	16.5	16 3/8	-	-	3/8	3/4
MC35B3XH1	22	17.5		16.5	16 3/8	-	-	3/8	3/4
MC35B4FH1	22	17.5		16.5	16 3/8	-	-	3/8	3/4
MC35B4GH1	22	17.5		16.5	16 3/8	-	-	3/8	3/4
MC35B4HH1	22	17.5		16.5	16 3/8	-	-	3/8	3/4
MC35B4MH1	22	17.5		16.5	16 3/8	-	-	3/8	3/4
MC35C2AH1	22	21		20	19 7/8	-	-	3/8	3/4
MC35C3XH(1,2)	26.5/22	21		20	19 7/8	-	-	3/8	3/4
MC35C4FH1	22	21		20	19 7/8	-	-	3/8	3/4
MC35C4GH1	22	21		20	19 7/8	-	-	3/8	3/4
MC35C4HH1	22	21		20	19 7/8	-	-	3/8	3/4
MC35C4MH1	22	21		20	19 7/8	-	-	3/8	3/4

For notes, see Page 3.

DIMENSIONS

Models	Dimensions					Wiring K.O.'s ¹		Refrigerant Connections		
	A	B	C	D	E	J	K	Line Size		
	Height	Width	Total Height			Power	Control	Liquid	Vapor	
MC36B2AH1	26.5	17.5	47 to 57 Depending on combination	16.5	16 3/8	-	-	3/8	7/8	
MC36B3XH1	26.5	17.5		16.5	16 3/8	-	-	3/8	7/8	
MC36B4EH1	26.5	17.5		16.5	16 3/8	-	-	3/8	7/8	
MC36B4FH1	26.5	17.5		16.5	16 3/8	-	-	3/8	7/8	
MC36B4GH1	26.5	17.5		16.5	16 3/8	-	-	3/8	7/8	
MC36B4HH1	26.5	17.5		16.5	16 3/8	-	-	3/8	7/8	
MC36C2AH1	26.5	21		20	19 7/8	-	-	3/8	7/8	
MC36C3XH1	26.5	21		20	19 7/8	-	-	3/8	7/8	
MC36C4EH1	26.5	21		20	19 7/8	-	-	3/8	7/8	
MC36C4GH1	26.5	21		20	19 7/8	-	-	3/8	7/8	
MC36C4HH1	26.5	21		20	19 7/8	-	-	3/8	7/8	
MC42B2CH1	32	17.5	47 to 57 Depending on combination	16.5	16 3/8	-	-	3/8	7/8	
MC42B3XH1	32	17.5		16.5	16 3/8	-	-	3/8	7/8	
MC42B4FH1	32	17.5		16.5	16 3/8	-	-	3/8	7/8	
MC42B4HH1	32	17.5		16.5	16 3/8	-	-	3/8	7/8	
MC42C2CH1	32	21		20	19 7/8	-	-	3/8	7/8	
MC42C3XH1	32	21		20	19 7/8	-	-	3/8	7/8	
MC42C4FH1	32	21		20	19 7/8	-	-	3/8	7/8	
MC42C4HH1	32	21		20	19 7/8	-	-	3/8	7/8	
MC43B2CH1	26.5	17.5	47 to 57 Depending on combination	16.5	16 3/8	-	-	3/8	7/8	
MC43B3XH1	26.5	17.5		16.5	16 3/8	-	-	3/8	7/8	
MC43B4GH1	26.5	17.5		16.5	16 3/8	-	-	3/8	7/8	
MC43B4KH1	26.5	17.5		16.5	16 3/8	-	-	3/8	7/8	
MC43B4MH1	26.5	17.5		16.5	16 3/8	-	-	3/8	7/8	
MC43C2CH1	26.5	21		20	19 7/8	-	-	3/8	7/8	
MC43C3XH1	26.5	21		20	19 7/8	-	-	3/8	7/8	
MC43C4GH1	26.5	21		20	19 7/8	-	-	3/8	7/8	
MC43C4KH1	26.5	21		20	19 7/8	-	-	3/8	7/8	
MC43C4MH1	26.5	21		20	19 7/8	-	-	3/8	7/8	
MC48C2CH1	32	21	47 to 57 Depending on combination	20	19 7/8	-	-	3/8	7/8	
MC48C3XH1	32	21		20	19 7/8	-	-	3/8	7/8	
MC48C4FH1	32	21		20	19 7/8	-	-	3/8	7/8	
MC48C4HH1	32	21		20	19 7/8	-	-	3/8	7/8	
MC48C4JH1	32	21		20	19 7/8	-	-	3/8	7/8	
MC48C4KH1	32	21		20	19 7/8	-	-	3/8	7/8	
MC48D2CH1	32	24.5		23.5	23 3/8	-	-	3/8	7/8	
MC48D3XH1	32	24.5		23.5	23 3/8	-	-	3/8	7/8	
MC48D4FH1	32	24.5		23.5	23 3/8	-	-	3/8	7/8	
MC48D4HH1	32	24.5		23.5	23 3/8	-	-	3/8	7/8	
MC48D4JH1	32	24.5		23.5	23 3/8	-	-	3/8	7/8	
MC48D4KH1	32	24.5		23.5	23 3/8	-	-	3/8	7/8	
MC60D2CH1	32	24.5		47 to 57 Depending on combination	23.5	23 3/8	-	-	3/8	7/8
MC60D3XH1	32	24.5			23.5	23 3/8	-	-	3/8	7/8
MC60D4GH1	32	24.5	23.5		23 3/8	-	-	3/8	7/8	
MC60D4HH1	32	24.5	23.5		23 3/8	-	-	3/8	7/8	
MC60D4JH1	32	24.5	23.5		23 3/8	-	-	3/8	7/8	
MC60D4KH1	32	24.5	23.5		23 3/8	-	-	3/8	7/8	
MC62D2CH1	36	24.5	61	23.5	23 3/8	-	-	3/8	7/8	
MC62D3XH1	36	24.5		23.5	23 3/8	-	-	3/8	7/8	
MC62D4HH1	36	24.5		23.5	23 3/8	-	-	3/8	7/8	
MC62D4JH1	36	24.5		23.5	23 3/8	-	-	3/8	7/8	
MC62D4KH1	36	24.5	23.5	23 3/8	-	-	3/8	7/8		

All MC coils include a factory installed horizontal drain pan.
(3X) = Models require field installed metering device.

1. Parenthesis indicate conduit size.

2. May be either 115-1-60, 208/230-1-60 or 460-3-60.

** Thermal Expansion Device Indicators - "2" indicates R-22 TXV is factory installed, "3X" indicates unit is a flex-coil model with a field installed R-22 or R-410A TXV, and "4" indicates R-410A TXV is factory installed. Letter indicates TXV size as required, see outdoor unit technical information for proper matches and requirements.

"H" models are available with a factory installed horizontal drain pan.

COOLING CAPACITY - Coil Only

Blower Models	Coil Models	Rated CFM	Entering Air °F (Dry / Wet Bulb)	MBH @ Evaporator Temperature and Corresponding Pressure °F / PSIG			
				35 / 61.5	40 / 68.5	45 / 76.0	50 / 84.0
Multi-Position - Upflow / Downflow / Horizontal							
MA08B	MC18B**H	650	85 / 72	28.7	26.1	23.3	20.2
			80 / 67	26.4	23.9	21.1	18.2
			75 / 62	21.6	19.2	16.6	14.0
			70 / 57	17.5	15.2	12.8	10.0
	MC24B**H	850	85 / 72	36.3	33.0	29.5	25.6
			80 / 67	33.4	30.2	26.7	23.1
			75 / 62	27.4	24.3	21.0	17.7
			70 / 57	22.2	19.3	16.2	12.6
MA12B	MC30B**H	1025	85 / 72	41.5	37.8	33.7	29.5
			80 / 67	36.2	32.4	28.6	24.5
			75 / 62	29.1	25.3	24.0	19.2
			70 / 57	24.1	21.5	18.7	15.8
	MC35B**H	1200	85 / 72	59.9	51.5	42.9	33.9
			80 / 67	48.0	40.3	32.8	25.1
			75 / 62	37.4	29.8	24.3	20.3
			70 / 57	32.1	28.1	22.9	19.2
	MC36B**H MC43B**H	1250	85 / 72	52.0	47.3	42.3	37.3
			80 / 67	41.7	36.8	32.3	27.4
			75 / 62	32.5	27.3	29.8	22.2
			70 / 57	27.9	25.8	23.8	22.2
MA14D	MC48D**H	1125	85 / 72	46.8	42.4	37.6	33.0
			80 / 67	37.4	33.3	29.4	24.3
			75 / 62	28.9	24.6	21.7	19.6
			70 / 57	25.1	23.3	21.7	19.6
	MC60D**H	1275	85 / 72	53.7	48.4	43.5	37.5
			80 / 67	43.0	38.0	33.3	27.7
			75 / 62	33.1	28.1	24.5	22.4
			70 / 57	28.8	26.5	24.5	22.4
	MC62D**H	1450	85 / 72	84.8	71.4	57.9	43.9
			80 / 67	67.9	56.0	44.2	32.4
			75 / 62	52.9	41.4	32.6	26.2
			70 / 57	45.4	39.1	31.4	25.9
MA16C	MC35C**H	1200	85 / 72	59.9	51.5	42.9	33.9
			80 / 67	48.0	40.3	32.8	25.1
			75 / 62	37.4	29.8	24.3	20.3
			70 / 57	32.1	28.1	22.9	19.2
	MC42C**H	1400	85 / 72	88.4	76.0	63.3	50.0
			80 / 67	70.8	59.4	48.4	37.0
			75 / 62	55.2	43.9	35.8	29.9
			70 / 57	47.4	41.5	35.8	29.9
	MC43C**H	1400	85 / 72	78.3	67.4	56.1	44.3
			80 / 67	62.7	52.6	42.9	32.8
			75 / 62	48.9	38.9	31.7	26.5
			70 / 57	42.0	36.8	29.9	25.1
	MC48C**H	1650	85 / 72	83.9	72.1	60.1	47.4
			80 / 67	67.2	56.4	45.9	35.1
			75 / 62	52.4	41.7	33.9	28.4
			70 / 57	45.0	39.4	33.0	27.0
MA20D	MC48D**H	1650	85 / 72	83.9	72.1	60.1	47.4
			80 / 67	67.2	56.4	45.9	35.1
			75 / 62	52.4	41.7	33.9	28.4
			70 / 57	45.0	39.4	33.0	27.0
	MC60D**H	1825	85 / 72	102.9	86.7	70.3	53.3
			80 / 67	82.4	68.0	53.7	39.4
			75 / 62	64.2	50.3	39.6	31.8
			70 / 57	55.1	47.5	38.1	30.3
	MC62D**H	2000	85 / 72	107.0	90.2	73.1	55.5
			80 / 67	85.7	70.7	55.8	40.9
			75 / 62	66.7	52.3	41.2	33.1
			70 / 57	57.4	49.4	39.7	31.6

Physical & Electrical Data

MA Models		MA08BN21	MA12BN11	MA12BN21	MA12BN41	MA14DN21	
Blower - Diameter x Width		10 x 9	10 x 9	10 x 9	10 x 9	10 x 10	
Motor	HP	1/4 HP	3/4 HP	3/4 HP	3/4 HP	1/2 HP	
	Nominal RPM	1075	1075	1075	1075	1075	
Voltage		208 / 230	115	208 / 230	460	208 / 230	
Amps	Full Load	1.5	9.8	3.5	2.3	2.4	
Permanent Filter ¹	Type	DISPOSABLE OR PERMANENT					
	Size	16 x 20 x 1	16 x 20 x 1	16 x 20 x 1	16 x 20 x 1	24 x 20 x 1	
	Filter Bulk Pack	1PF0601BK	1PF0601BK	1PF0601BK	1PF0601BK	1PF0604BK	
Shipping / Operating Weight (lbs.)		75 / 71	82 / 78	82 / 78	82 / 78	94 / 88	
MA Models		MA16CN11	MA16CN21	MA16CN41	MA20DN11	MA20DN21	MA20DN41
Blower - Diameter x Width		10 x 10	10 x 10	10 x 10	11 x 10	11 x 10	11 x 10
Motor	HP	1 HP	1 HP	1 HP	1 HP	1 HP	1 HP
	Nominal RPM	1075	1075	1075	1075	1075	1075
Voltage		115	208 / 230	460	115	208 / 230	460
Amps	Full Load	11.4	4.0	2.6	11.2	7.4	3.7
Permanent Filter ¹	Type	DISPOSABLE OR PERMANENT					
	Size	20 x 20 x 1	20 x 20 x 1	20 x 20 x 1	24 x 20 x 1	24 x 20 x 1	24 x 20 x 1
	Filter Bulk Pack	1PF0602BK	1PF0602BK	1PF0602BK	1PF0604BK	1PF0604BK	1PF0604BK
Shipping / Operating Weight (lbs.)		90 / 84	90 / 84	90 / 84	97 / 91	97 / 91	97 / 91

1. Field Supplied.

Full Cased "A" Type Multi-Postion

Model	Application	Refrig. Conn. Types	Face Area (Sq. Ft.)	Rows Deep	Fin Per In.	Coil Size	Tube Geometry	Tube Dia.	Fin Type	TXV	Operating Weight (Lbs.)
MC18B3XH1	Cooling / Heat Pump	Sweat	3.40	2	14	(2) 14 x 17.5	1 x 0.866	3/8	Enhanced	None	53
MC18B3XH1										None	53
MC18B2AH1	Cooling / Heat Pump	Sweat	3.40	2	14	(2) 14 x 17.5	1 x 0.866	3/8	Enhanced	2A	53
MC18B4EH1										4E	53
MC24B3XH1	Cooling / Heat Pump	Sweat	4.38	2	14	(2) 18 x 17.5	1 x 0.866	3/8	Enhanced	None	56
MC24B2AH1										2A	56
MC24B4FH1										4F	56
MC30B3XH1	Cooling / Heat Pump	Sweat	4.38	2	14	(2) 18 x 17.5	1 x 0.866	3/8	Enhanced	None	56
MC30B2AH1										2A	56
MC30B4EH1										4E	56
MC30B4FH1										4F	56
MC35B3XH2	Cooling / Heat Pump	Sweat	3.9	3	12	(2) 16 x 17.5	1 x 0.866	3/8	Enhanced	None	65
MC35B2AH1										2A	67
MC35B4FH1										4F	67
MC35B4GH1										4G	67
MC35B4HH1										4H	67
MC35B4MH1										4M	67
MC35C3XH(1,2)										Cooling / Heat Pump	Sweat
MC35C2AH1	2A	69									
MC35C4FH1	4F	69									
MC35C4GH1	4G	69									
MC35C4HH1	4H	69									
MC35C4MH1	4M	69									
MC36B3XH1	Cooling / Heat Pump	Sweat	4.86	2	14	(2) 20 x 17.5	1 x 0.866	3/8	Enhanced	None	65
MC36B2AH1										2A	65
MC36B4EH1										4E	65
MC36B4FH1										4F	65
MC36B4GH1										4G	65
MC36B4HH1										4H	65

For notes, see Page 6.

Full Cased "A" Type Multi-Postion (Continued)

Model	Application	Refrig. Conn. Types	Face Area (Sq. Ft.)	Rows Deep	Fin Per In.	Coil Size	Tube Geometry	Tube Dia.	Fin Type	TXV	Operating Weight (Lbs.)
MC36C3XH1	Cooling / Heat Pump	Sweat	4.86	2	14	(2) 20 x 17.5	1 x 0.866	3/8	Enhanced	None	65
MC36C2AH1										2A	65
MC36C4EH1										4E	65
MC36C4GH1										4G	65
MC36C4HH1										4H	65
MC42B3XH1	Cooling / Heat Pump	Sweat	5.83	2	14	(2) 24 x 17.5	1 x 0.866	3/8	Enhanced	None	72
MC42B2CH1										2C	72
MC42B4FH1										4F	72
MC42B4HH1										4H	72
MC42C3XH1	Cooling / Heat Pump	Sweat	5.83	2	14	(2) 24 x 17.5	1 x 0.866	3/8	Enhanced	None	72
MC42C2CH1										2C	72
MC42C4FH1										4F	72
MC42C4HH1										4H	72
MC43B3XH1	Cooling / Heat Pump	Sweat	4.86	3	12	(2) 20 x 17.5	1 x 0.866	3/8	Enhanced	None	73
MC43B2CH1										2C	73
MC43B4GH1										4G	73
MC43B4KH1										4K	73
MC43B4MH1										4M	73
MC43C3XH1	Cooling / Heat Pump	Sweat	4.86	3	12	(2) 20 x 17.5	1 x 0.866	3/8	Enhanced	None	75
MC43C2CH1										2C	75
MC43C4GH1										4G	75
MC43C4KH1										4K	75
MC43C4MH1										4M	75
MC48C3XH1	Cooling / Heat Pump	Sweat	5.35	3	12	(2) 22 x 17.5	1 x 0.866	3/8	Enhanced	None	82
MC48C2CH1										2C	82
MC48C4FH1										4F	82
MC48C4HH1										4H	82
MC48C4JH1										4J	82
MC48C4KH1										4K	82
MC48D3XH1	Cooling / Heat Pump	Sweat	5.35	3	12	(2) 22 x 17.5	1 x 0.866	3/8	Enhanced	None	82
MC48D2CH1										2C	82
MC48D4FH1										4F	82
MC48D4HH1										4H	82
MC48D4JH1										4J	82
MC48D4KH1										4K	82
MC60D3XH1	Cooling / Heat Pump	Sweat	5.83	3	12	(2) 24 x 17.5	1 x 0.866	3/8	Enhanced	None	86
MC60D2CH1										2C	86
MC60D4GH1										4G	86
MC60D4HH1										4H	86
MC60D4JH1										4J	86
MC60D4KH1										4K	86
MC62D3XH1	Cooling / Heat Pump	Sweat	6.80	3	12	(2) 28 x 17.5	1 x 0.866	3/8	Enhanced	None	98
MC62D2CH1										2C	98
MC62D4HH1										4H	98
MC62D4JH1										4J	98
MC62D4KH1										4K	98

Note: MC coils available with a factory installed horizontal drain pan option (H).

ELECTRICAL DATA - 208/230-1-60

MA Models	Heater Models*	Max. Static	Min. Speed Tap	Total Heat ¹				KW Staging					
				KW		MBH		W1 Only		W2 Only		W1 + W2	
				208V	240V	208V	240V	208V	240V	208V	240V	208V	240V
MA08BN2	4HK*6500206	0.5	Lo	1.9	2.5	6.4	8.5	1.9	2.5	1.9	2.5	1.9	2.5
	4HK*6500506	0.5	Lo	3.6	4.8	12.3	16.4	3.6	4.8	3.6	4.8	3.6	4.8
	4HK*6500806	0.5	Med	5.6	7.5	19.2	25.6	2.8	3.75	5.6	7.5	5.6	7.5
	4HK*6501006	0.5	Hi	7.2	9.6	24.6	32.8	3.6	4.8	7.2	9.6	7.2	9.6
	4HK16501306	0.5	Hi	9.8	13.0	33.3	44.4	3.3	4.3	6.5	8.6	9.8	13.0
MA12BN2	4HK*6500506	0.5	Lo	3.6	4.8	12.3	16.4	3.6	4.8	3.6	4.8	3.6	4.8
	4HK*6500806	0.5	Med	5.6	7.5	19.2	25.6	2.8	3.75	5.6	7.5	5.6	7.5
	4HK*6501006	0.5	Med	7.2	9.6	24.6	32.8	3.6	4.8	7.2	9.6	7.2	9.6
	4HK16501306	0.5	Med	9.8	13.0	33.3	44.4	3.3	4.3	6.5	8.6	9.8	13.0
	4HK165N1506	0.5	Med	10.8	14.4	36.9	49.1	3.6	4.8	7.2	9.6	10.8	14.4
MA14DN2	4HK*6500506	0.5	Lo	3.6	4.8	12.3	16.4	3.6	4.8	3.6	4.8	3.6	4.8
	4HK*6500806	0.5	Lo	5.6	7.5	19.2	25.6	2.8	3.75	5.6	7.5	5.6	7.5
	4HK*6501006	0.5	Med	7.2	9.6	24.6	32.8	3.6	4.8	7.2	9.6	7.2	9.6
	4HK16501506	0.5	Med	10.8	14.4	36.9	49.1	3.6	4.8	7.2	9.6	10.8	14.4
	4HK16501806	0.5	Hi	13.2	17.6	45.1	60.1	3.3	4.4	6.6	8.8	13.2	17.6
	4HK16502006	0.5	Hi	14.4	19.2	49.2	65.5	3.6	4.8	7.2	9.6	14.4	19.2
MA16CN2	4HK*6500506	0.5	Lo	3.6	4.8	12.3	16.4	3.6	4.8	3.6	4.8	3.6	4.8
	4HK*6500806	0.5	Lo	5.6	7.5	19.2	25.6	2.8	3.75	5.6	7.5	5.6	7.5
	4HK*6501006	0.5	Med	7.2	9.6	24.6	32.8	3.6	4.8	7.2	9.6	7.2	9.6
	4HK16501506	0.5	Med	10.8	14.4	36.9	49.1	3.6	4.8	7.2	9.6	10.8	14.4
	4HK16501806	0.5	Hi	13.2	17.6	45.1	60.1	3.3	4.4	6.6	8.8	13.2	17.6
	4HK16502006	0.5	Hi	14.4	19.2	49.2	65.5	3.6	4.8	7.2	9.6	14.4	19.2
MA20DN2	4HK*6500806	0.5	Lo	5.6	7.5	19.2	25.6	2.8	3.75	5.6	7.5	5.6	7.5
	4HK*6501006	0.5	Lo	7.2	9.6	24.6	32.8	3.6	4.8	7.2	9.6	7.2	9.6
	4HK16501506	0.5	Med	10.8	14.4	36.9	49.1	3.6	4.8	7.2	9.6	10.8	14.4
	4HK16501806	0.5	Med	13.2	17.6	45.1	60.1	3.3	4.4	6.6	8.8	13.2	17.6
	4HK16502006	0.5	Med	14.4	19.2	49.2	65.5	3.6	4.8	7.2	9.6	14.4	19.2
	4HK16502506	0.5	Med	18.0	24.0	61.5	81.9	3.6	4.8	10.8	14.4	18.0	24.0

1. See conversion Page 7.

* May be 0 (no breaker) or 1 (with breaker).

ELECTRICAL DATA - 208/230-3-60

MA Models	Heat Kit - Three Phase	Max. Static	Min. Speed Tap	Total Heat ¹				KW Staging					
				KW		MBH		W1 Only		W2 Only		W1 + W2	
				208V	240V	208V	240V	208V	240V	208V	240V	208V	240V
MA08BN2	4HK06501025	0.5	Hi	7.2	9.6	24.6	32.8	7.2	9.6	7.2	9.6	7.2	9.6
MA12BN2	4HK06501025	0.5	Med	7.2	9.6	24.6	32.8	7.2	9.6	7.2	9.6	7.2	9.6
	4HK065N1525	0.5	Hi	10.8	14.4	36.9	49.1	10.8	14.4	10.8	14.4	10.8	14.4
MA14DN2	4HK06501025	0.5	Med	7.2	9.6	24.6	32.8	7.2	9.6	7.2	9.6	7.2	9.6
	4HK06501525	0.5	Med	10.8	14.4	36.9	49.1	10.8	14.4	10.8	14.4	10.8	14.4
	4HK06501825	0.5	Hi	12.9	17.2	44.7	58.7	12.9	17.2	12.9	17.2	12.9	17.2
MA16CN2	4HK06501025	0.5	Med	7.2	9.6	24.6	32.8	7.2	9.6	7.2	9.6	7.2	9.6
	4HK06501525	0.5	Med	10.8	14.4	36.9	49.1	10.8	14.4	10.8	14.4	10.8	14.4
	4HK06501825	0.5	Hi	12.9	17.2	44.7	58.7	12.9	17.2	12.9	17.2	12.9	17.2
MA20DN2	4HK06501025	0.5	Lo	7.2	9.6	24.6	32.8	7.2	9.6	7.2	9.6	7.2	9.6
	4HK06501525	0.5	Med	10.8	14.4	36.9	49.1	10.8	14.4	10.8	14.4	10.8	14.4
	4HK16501825	0.5	Med	12.9	17.2	44.7	58.7	12.9	17.2	12.9	17.2	12.9	17.2
	4HK16502525	0.5	Med	18.0	24.0	61.4	81.4	9.0	12.0	18.0	24.0	18.0	24.0

1. See conversion Page 7.

ELECTRICAL DATA - 460-3-60

MA Models	Heater Models	MAX. STATIC & MIN. CFM		Total Heat ¹		KW Staging		
				KW	MBH	W1 Only	W2 Only	W1 + W2
		Static	Taps	480V	480V	480V	480V	480V
MA12BN41	4HK06501046	0.5"	Med	9.6	3.28	9.6	9.6	9.6
MA16CN41	4HK06501046	0.5"	Med	9.6	3.28	9.6	9.6	9.6
	4HK06501546	0.5"	Med	14.4	4.92	14.4	14.4	14.4
MA20DN41	4HK06501046	0.5"	Med	9.6	3.28	9.6	9.6	9.6
	4HK06501546	0.5"	Med	14.4	4.92	14.4	14.4	14.4
	4HK06502946	0.5"	Med	28.8	9.84	14.4	28.8	28.8

ELECTRICAL DATA (For Single Source Power Supply) - Copper Wire 208/230-1-60

MA Models	Heater Models*	Field Wiring							
		Heater Amps	Ampacity Min. Circuit			Max. O.C.P. ¹ Amps/Type		Wire Size - AWG 75°C	
		240V	208V	240V	208V	240V	208V	240V	
MA08B	4HK*6500206	10.4	13.03	14.88	15	15	14	14	
	4HK*6500506	20.0	23.42	26.88	30	30	10	10	
	4HK*6500806	31.3	35.60	41.00	40	45	8	8	
	4HK*6501006	40.0	45.08	51.88	50	60	8	6	
	4HK16501306	54.2	60.4	69.6	70	70	4	4	
MA12B	4HK*6500506	20.0	25.79	29.38	30	30	10	10	
	4HK*6500806	31.3	37.98	43.50	40	45	8	8	
	4HK*6501006	40.0	47.46	54.38	50	60	8	6	
	4HK16501306	54.2	61.3	72.1	70	90	4	3	
	4HK165N1506	60.0	69.13	79.38	70	90	4	3	
MA14D	4HK*6500506	20.0	24.29	28.00	30	30	8	8	
	4HK*6500806	31.3	36.48	42.13	40	45	8	8	
	4HK*6501006	40.0	45.96	53.00	50	60	8	6	
	4HK16501506	60.0	67.63	78.00	70	90	4	3	
	4HK16501806	73.3	82.07	94.63	90	100	4	3	
	4HK16502006	80.0	89.29	103.00	100	110	3	2	
MA16C	4HK*6500506	20.0	26.17	30.00	30	30	8	10	
	4HK*6500806	31.3	38.35	44.13	40	45	8	8	
	4HK*6501006	40.0	47.83	55.00	50	60	8	6	
	4HK16501506	60.0	69.50	80.00	70	90	4	3	
	4HK16501806	73.3	83.94	96.63	90	100	4	3	
	4HK16502006	80.0	91.17	105.00	100	110	3	2	
MA20D	4HK*6500806	31.3	42.60	48.38	45	50	8	8	
	4HK*6501006	40.0	52.08	59.25	60	60	8	6	
	4HK16501506	60.0	73.75	84.25	90	90	3	3	
	4HK16501806	73.3	88.19	100.88	90	110	3	2	
	4HK16502006	80.0	95.42	109.25	100	125	3	2	
	4HK16502506	100.0	117.08	134.25	125	150	1	1/0	

1. OCP = Over Current Protection device, must be HACR type Circuit Breaker or Time Delay fuse.

* May be 0 (no breaker) or 1 (with breaker).

ELECTRICAL DATA (For Single Source Power Supply) - Copper Wire 208/230-3-60

MA Models	Heat Kit - Three Phase ¹	Heater Amps 240V	Field Wiring					
			Min. Circuit Ampacity		Max. O.C.P. ² Amps/Type		75°C Wire Size - AWG	
			208V	240V	208V	240V	208V	240V
MA08B	4HK06501025	23.1	26.8	30.8	30	35	10	8
MA12B	4HK06501025	23.1	27.6	31.9	30	35	10	8
	4HK065N1525	34.7	40.1	47.8	45	50	8	8
MA14D	4HK06501025	23.1	29.1	33.3	30	35	10	8
	4HK06501525	34.7	41.6	46.4	45	50	8	8
	4HK06501825	41.4	48.9	56.1	50	60	8	6
MA16C	4HK06501025	23.1	29.5	33.9	30	35	10	8
	4HK06501525	34.7	42.0	48.4	45	50	8	8
	4HK06501825	41.4	49.3	56.8	50	60	6	6
MA20D	4HK06501025	23.1	33.8	38.1	35	40	8	8
	4HK06501525	34.7	43.5	52.6	45	60	8	6

1. Heaters are 3 Phase.

2. O.C.P. = Over Current Protection device, must be HACR type Circuit Breaker or Time Delay fuse.

ELECTRICAL DATA (For Single Source Power Supply) - Copper Wire 460-3-60

MA Models	Heater Models	Field Wiring		
		Min. Circuit Ampacity	Max. O.C.P. ¹ Amps/Type	Wire Size - AWG 75°C
		480V	480V	480V
MA12BN41	4HK06501046	17.4	20	12
MA16CN41	4HK06501046	17.8	25	10
	4HK06501546	24.9	25	10
MA20DN41	4HK06501046	19.1	25	10
	4HK06501546	26.3	30	8
	4HK06502946	48.0	50	8

1. OCP = Over Current Protection device, must be HACR type Circuit Breaker or Time Delay fuse.

ELECTRICAL DATA (For Multi Source Power Supply) - Copper Wire 208/230-1-60

MA Models	Heater Models	Min. Circuit Ampacity			Max. O.C.P. ¹ Amps/Type			75°C Wire Size - AWG		
		Circuit			Circuit			Circuit		
		1st	2nd	3rd	1st	2nd	3rd	1st	2nd	3rd
		208 / 240	208 / 240	208 / 240	208 / 240	208 / 240	208 / 240	208 / 240	208 / 240	208 / 240
MA12BN2	4HK16501306	41.8 / 49.5	19.5 / 22.5	- / -	45 / 50	20 / 25	- / -	8 / 8	10 / 10	- / -
	4HK165N1506	47.5 / 54.4	21.7 / 25.0	- / -	50 / 60	25 / 25	- / -	8 / 6	10 / 10	- / -
MA16CN2	4HK16501506	47.8 / 55.0	21.7 / 25.0	- / -	50 / 60	25 / 25	- / -	8 / 6	10 / 10	- / -
	4HK16501806	44.2 / 50.8	39.7 / 45.8	- / -	50 / 60	40 / 50	- / -	8 / 6	8 / 8	- / -
	4HK16502006	47.8 / 55.0	43.3 / 50.0	- / -	50 / 60	45 / 50	- / -	8 / 6	8 / 8	- / -
MA14DN2	4HK16501506	46.0 / 53.0	21.7 / 25.0	- / -	50 / 60	25 / 25	- / -	8 / 6	10 / 10	- / -
	4HK16501806	42.3 / 48.8	39.7 / 45.7	- / -	45 / 50	40 / 50	- / -	8 / 8	8 / 8	- / -
	4HK16502006	46.0 / 53.0	43.3 / 50.0	- / -	50 / 60	45 / 50	- / -	8 / 6	8 / 8	- / -
MA20DN2	4HK16501506	49.3 / 56.5	21.7 / 25.0	- / -	50 / 60	25 / 25	- / -	8 / 6	10 / 10	- / -
	4HK16501806	45.7 / 52.3	39.7 / 45.8	- / -	50 / 60	40 / 50	- / -	8 / 6	8 / 8	- / -
	4HK16502006	49.3 / 56.5	43.3 / 50.0	- / -	50 / 60	45 / 50	- / -	8 / 6	8 / 8	- / -
	4HK16502506	49.3 / 56.5	43.3 / 50.0	21.7 / 25.0	50 / 60	45 / 50	25 / 25	8 / 6	8 / 8	10 / 10

1. OCP = Over Current Protection device, must be HACR type Circuit Breaker or Time Delay fuse.

ELECTRICAL DATA (For Multi Source Power Supply) - Copper Wire 208/230-3-60

MA Models	Heater Model	Minimum Circuit Ampacity			Max OCP ¹ Amps/Type			75°C Wire Size - AWG		
		Circuit								
		1st	2nd	3rd	1st	2nd	3rd	1st	2nd	3rd
		208/240	208/240	208/240	208/240	208/240	208/240	208/240	208/240	208/240
MA20DN2	4HK16501825	31.1 / 35.1	22.4 / 25.9	- / -	35 / 40	25 / 30	- / -	8 / 8	10 / 10	- / -
	4HK16502525	40.0 / 45.4	31.3 / 36.1	- / -	40 / 50	35 / 40	- / -	8 / 8	8 / 8	- / -

1. OCP = Over Current Protection device, must be HACR type Circuit Breaker or Time Delay fuse.

KW & MBH Conversions

FOR	208-VOLT	OPERATION MULTIPLY	240-VOLT	TABULATED KW & MBH BY	.751
	230-VOLT		240-VOLT		.918
	220-VOLT		240-VOLT		.840

ELECTRICAL DATA - Cooling Only (60 Hz) - 208/230 - (Copper Wire)

Models MA	Total Motor Amps		Minimum Circuit Ampacity		Max. O.C.P. ¹ Amps/Type	Minimum Wire Size A.W.G.
	60 Hertz		60 Hertz			
	208V	230V	208V	230V		
MA08BN21	1.4	1.5	1.8	1.9	15	14
MA12BN21	2.1	3.5	2.6	3.0	15	14
MA14DN21	3.3	2.4	4.1	4.4	15	14
MA16CN21	3.6	4.0	4.5	5.0	15	14
MA20DN21	4.8	7.4	6.0	6.5	15	14

1. OCP = Over Current Protection device, must be HACR type Circuit Breaker or Time Delay fuse.

ELECTRICAL DATA - Cooling Only (60 Hz)- 115 - (Copper Wire)

Models MA	Total Motor Amps	Minimum Circuit Ampacity	Max. O.C.P. ¹ Amps/Type	Minimum Wire Size A.W.G.
	60 Hertz	60 Hertz		
	115V	115V		
MA12BN11	9.8	12.3	15	14
MA16CN11	11.4	14.0	15	14
MA20DN11	11.2	14.3	15	14

1. OCP = Over Current Protection device, must be HACR type Circuit Breaker or Time Delay fuse.

ELECTRICAL DATA - Cooling Only (60 Hz) - 460 - (Copper Wire)

Models MA	Total Motor Amps	Minimum Circuit Ampacity	Max. O.C.P. ¹ Amps/Type	Minimum Wire Size A.W.G.
	60 Hertz	60 Hertz		
MA12BN41	2.3	3.5	15	14
MA16CN41	2.6	3.9	15	14
MA20DN41	3.7	5.6	15	14

1. OCP = Over Current Protection device, must be HACR type Circuit Breaker or Time Delay fuse.

POWER WIRING

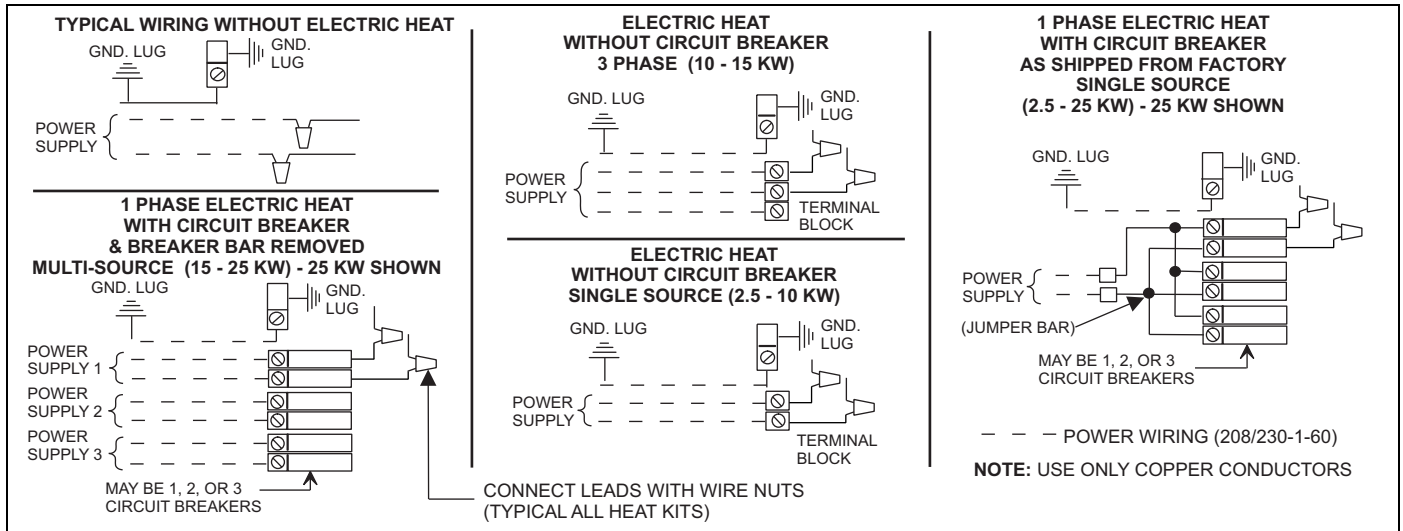

Line Connection

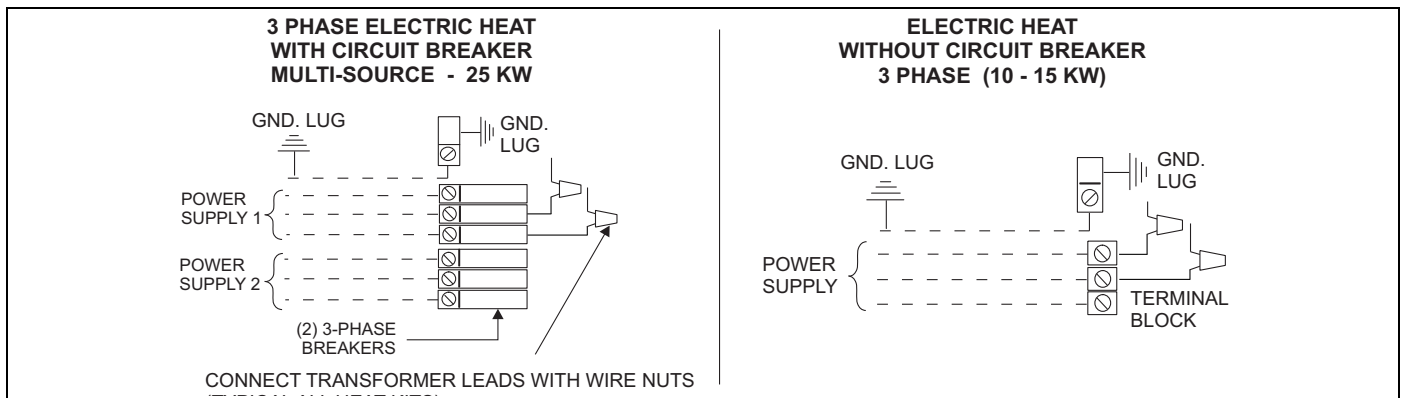

460V Line connections

BLOWER SPEED CONNECTIONS

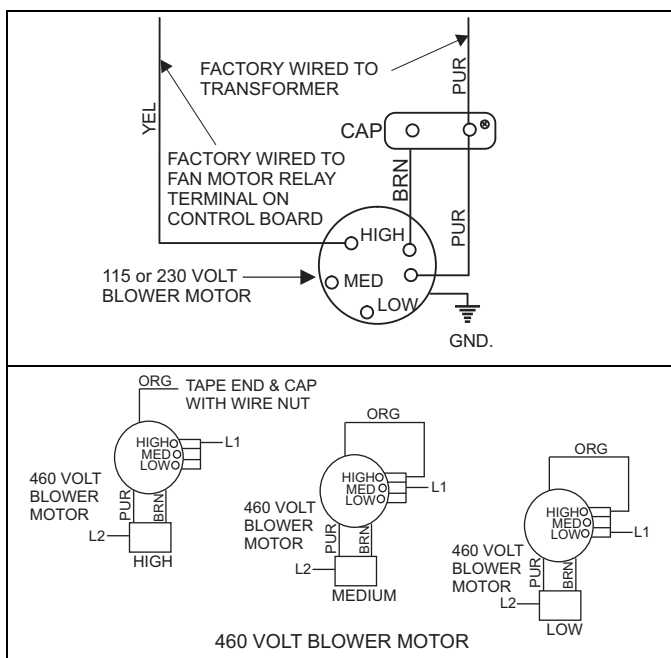

ACCESSORIES

Refer to Price Manual for specific model numbers.

Electric Heaters - Models shown under Electrical Data include sequencers and temperature limit switches and fusible links for safe, efficient operation. Circuit breakers are provided where shown. **Not for 115 Volt models.**

Suspension Kit - Suspension Kit Model 1BH0601 is designed specifically for upflow application of the units contained in this technical guide. For suspension of these units in horizontal applications, it is recommended to use angle support brackets with threaded rods at locations shown in air handler installation instructions.

Filter Rack - One of the following external filter rack accessories; 1FR0717, 1FR0721, 1FR0724 must be used when unit is installed in a downflow application.

Combustible Floor Base - If an electric heat accessory which is rated for greater than zero clearance to combustible surfaces is installed in these air handlers in the downflow operating positions on a combustible floor, one of the following combustible floor base accessories is required: 1FB1817, 1FB1821, or 1FB1824.

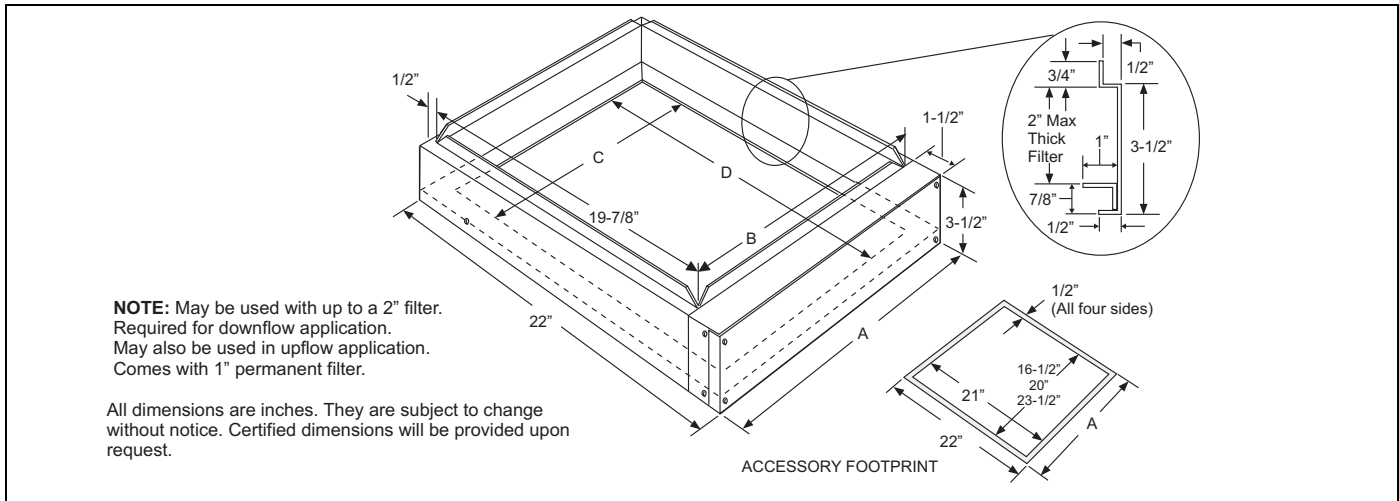

Filter Rack Accessory

DIMENSIONS

Filter Rack Models		Used With	Rack Dimensions Inches				Filter Dimensions Inches		
Multi-Position	Horizontal Only		A	B	C	D	Width	Length	Thickness
1FR0817	1FR0717	MA08B, MA12B	17-1/2	16-3/8	15-1/2	21	16	20	1
1FR0821	1FR0721	MA16C	21	19-7/8	19	21	20	20	1
1FR0824	1FR0724	MA14D, MA20D	24-1/2	23-3/8	22-1/2	21	24	20	1

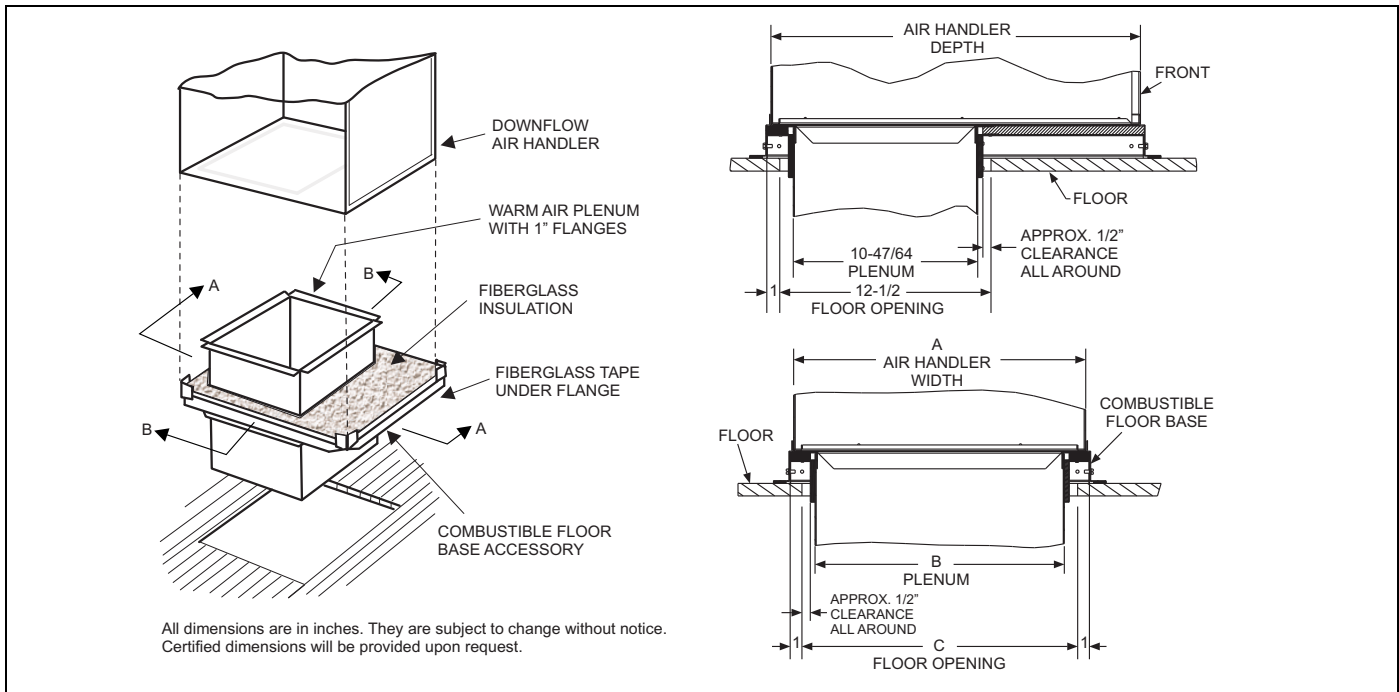

Combustible Floor Base Accessory

Floor Base Models	Used with	Dimensions			
		A	B	C	D
1FB1817	MA08B, MA12B	19.9	18.0	14.9	16.9
1FB1821	MA16C	23.4	21.5	18.4	20.4
1FB1824	MA14D, MA20D	26.9	25.0	21.9	23.9

NOTE: Air flow data shown above 0.50" W.C. external static pressure is for REFERENCE ONLY. Maximum allowable external static when electric heat is used is limited to 0.50" W.C. Maximum allowable external static pressure may also be limited by minimum CFM requirements for proper Heat Pump operation.

EXTENDED AIRFLOW DATA¹ - MA Models - 115 / 230 / 460 Volt - 60 Hz

MA Models	MC Models	Blower Motor Speed	CFM ¹ @ External Static Pressure - IWC									
			0.1	0.2	0.3	0.4	0.5	0.6	0.7	0.8	0.9	1
MA08B	MC18B	High	1102	986	870	754	638	521	405	289	173	57
		Med.	831	737	644	551	457	364	271	178	84	N/A
		Low	615	537	458	379	300	221	142	63	N/A	N/A
	MC24B	High	1112	1001	890	780	669	558	447	336	225	114
		Med.	851	759	667	576	484	392	300	208	116	25
		Low	643	562	480	399	317	236	154	73	N/A	N/A
MA12B	MC30B MC35B	High	1429	1363	1290	1212	1133	1037	929	670	534	375
		Med.	1213	1153	1097	1037	977	896	697	549	453	220
		Low	1075	1032	990	927	873	770	611	494	405	212
	MC36B	High	1607	1533	1463	1395	1319	1044	851	725	673	673
		Med.	1308	1258	1197	1146	1097	887	742	648	608	609
		Low	1148	1108	1061	1017	976	807	690	613	582	582
	MC43B	High	1462	1396	1322	1254	1172	1067	941	693	585	464
		Med.	1205	1154	1102	1046	980	897	704	560	441	220
		Low	1075	1020	969	906	842	735	592	470	364	190
MA14D	MC48D	High	1715	1671	1608	1547	1460	1338	1232	1003	727	508
		Med.	1471	1438	1367	1318	1263	1180	920	824	587	503
		Low	1379	1330	1276	1227	1157	1047	866	681	567	392
	MC60D	High	1763	1713	1649	1581	1511	1407	1276	995	852	N/A
		Med.	1487	1462	1412	1356	1280	1210	1087	795	726	N/A
		Low	1381	1353	1292	1225	1186	1057	863	780	669	N/A
	MC62D	High	1746	1699	1655	1579	1486	1399	1264	1093	796	581
		Med.	1486	1442	1393	1333	1270	1189	1081	776	628	450
		Low	1392	1336	1285	1226	1158	1061	882	740	680	445
MA16C	MC42C	High	1959	1874	1802	1708	1606	1486	1408	1264	953	810
		Med.	1631	1587	1542	1473	1395	1315	1218	967	821	533
		Low	1447	1431	1401	1363	1304	1241	1098	844	751	712
	MC43C MC35C	High	1825	1742	1660	1578	1486	1396	1306	1187	802	577
		Med.	1637	1572	1507	1431	1361	1276	1171	1043	722	493
		Low	1510	1456	1403	1341	1278	1202	1088	785	684	456
	MC48C	High	2018	1895	1772	1649	1525	1402	1279	1156	1033	910
		Med.	1684	1595	1506	1417	1328	1240	1151	1062	973	884
		Low	1561	1476	1392	1308	1223	1139	1055	970	896	801
MA20D	MC48D	High	2226	2190	2103	2035	1931	1845	1683	1541	1465	1328
		Med.	2115	2087	2017	1951	1851	1744	1542	1466	1406	1254
		Low	N/A	N/A	N/A	1716	1643	1554	1451	1379	1292	1151
	MC60D	High	2326	2235	2192	2107	2027	1906	1786	1538	1469	1368
		Med.	2150	2089	2036	2008	1944	1852	1692	1499	1416	1295
		Low	2012	1923	1834	1718	1676	1600	1447	1389	1311	1200
	MC62D	High	2357	2321	2254	2191	2139	1951	1859	1656	1556	1472
		Med.	2212	2144	2111	2069	1986	1862	1727	1566	1498	1369
		Low	2066	1934	1910	1817	1723	1646	1514	1442	1381	1245

NOTE: Air flow data shown above 0.50" W.C. external static pressure is for REFERENCE ONLY. Maximum allowable external static when electric heat is used is limited to 0.50" W.C. Maximum allowable external static pressure may also be limited by minimum CFM requirements for proper Heat Pump operation.

1. Includes Return Air Filter and Largest Electric Heater.

All AH, AV, MA, MV, SHP, SV series air handler units are UL Listed up to 0.50" w.c. external static pressure, including air filter, wet coil, and largest KW size heater.

EXTENDED AIRFLOW DATA¹ - MA Models

MA Models	MC Models	Blower Motor Speed	208 Volt - 60 Hz									
			CFM ¹ @ External Static Pressure - IWC									
			0.1	0.2	0.3	0.4	0.5	0.6	0.7	0.8	0.9	1
MA08B	MC18B	High	1080	964	848	732	615	499	383	267	150	34
		Med.	712	628	544	461	377	293	210	126	42	N/A
		Low	529	452	376	299	223	146	70	N/A	N/A	N/A
	MC24B	High	1039	932	825	717	610	502	395	288	180	73
		Med.	743	659	575	491	407	323	239	156	72	N/A
		Low	532	460	387	315	242	169	97	24	N/A	N/A
MA12B	MC30B MC35B	High	1399	1339	1267	1192	1098	1023	915	673	534	377
		Med.	1080	1039	994	943	876	778	639	525	415	211
		Low	932	895	868	829	776	656	543	447	351	214
	MC36B	High	1434	1267	1099	932	764	597	430	262	95	N/A
		Med.	1083	955	827	699	571	443	315	187	59	N/A
		Low	933	818	703	588	473	359	244	129	14	N/A
	MC43B	High	1444	1377	1311	1247	1172	1091	971	721	573	442
		Med.	1086	1047	1005	959	905	819	647	534	438	220
		Low	942	920	887	827	768	655	536	477	366	209
MA14D	MC48D	High	1549	1498	1448	1383	1325	1235	1125	936	658	548
		Med.	1275	1269	1225	1181	1115	997	811	684	548	392
		Low	1190	1162	1112	1074	975	817	737	625	493	358
	MC60D	High	1545	1490	1463	1378	1337	1231	1115	850	739	572
		Med.	1266	1248	1207	1140	1101	1005	839	687	564	469
		Low	1192	1186	1126	1067	992	842	740	638	507	347
	MC62D	High	1564	1520	1455	1400	1336	1257	1154	813	755	549
		Med.	1303	1262	1225	1165	1117	1028	827	744	590	398
		Low	1204	1161	1104	1060	1001	870	745	554	532	462
MA16C	MC42C	High	1782	1712	1619	1524	1435	1323	1213	985	798	557
		Med.	1468	1415	1355	1298	1233	1144	1005	791	669	493
		Low	1310	1278	1239	1185	1125	1045	934	725	561	424
	MC35C MC43C	High	1771	1705	1619	1528	1450	1361	1261	1102	721	504
		Med.	1486	1445	1393	1325	1265	1198	1041	791	663	457
		Low	1314	1300	1258	1214	1164	1108	891	753	550	410
	MC48C	High	1983	1865	1747	1629	1511	1393	1275	1157	1039	921
		Med.	1529	1446	1363	1280	1197	1114	1031	948	865	782
		Low	1312	1249	1185	1122	1059	995	932	868	805	742
MA20D	MC48D	High	2250	2180	2139	2062	1971	1855	1683	1553	1461	1342
		Med.	1953	1956	1905	1858	1755	1649	1528	1440	1355	1245
		Low	N/A	N/A	1544	1538	1455	1401	1346	1285	1195	1081
	MC60D	High	2251	2186	2144	2073	2003	1921	1809	1574	1478	1370
		Med.	1987	1945	1926	1887	1836	1761	1643	1472	1387	1213
		Low	1492	1517	1521	1523	1507	1436	1379	1308	1213	1128
	MC62D	High	2208	2123	2092	2054	1910	1762	1595	1496	1435	1298
		Med.	1959	1945	1913	1862	1766	1661	1513	1420	1315	1182
		Low	N/A	N/A	N/A	1546	1491	1407	1354	1258	1184	1088

NOTE: Air flow data shown above 0.50" W.C. external static pressure is for REFERENCE ONLY. Maximum allowable external static when electric heat is used is limited to 0.50" W.C. Maximum allowable external static pressure may also be limited by minimum CFM requirements for proper Heat Pump operation.

1. Includes Return Air Filter and Largest Electric Heater.

All AH, AV, MA, MV, SHP, SV series air handler units are UL Listed up to 0.50" w.c. external static pressure, including air filter, wet coil, and largest KW size heater.

APPLICATION FACTORS - Rated CFM vs. Actual CFM

% OF RATED AIR FLOW	80%	90%	RATED CFM	110%	120%
CAPACITY FACTOR	0.96	0.98	1.00	1.02	1.03

COOLING MODELS WITH/WITHOUT ELECTRIC HEAT WIRING

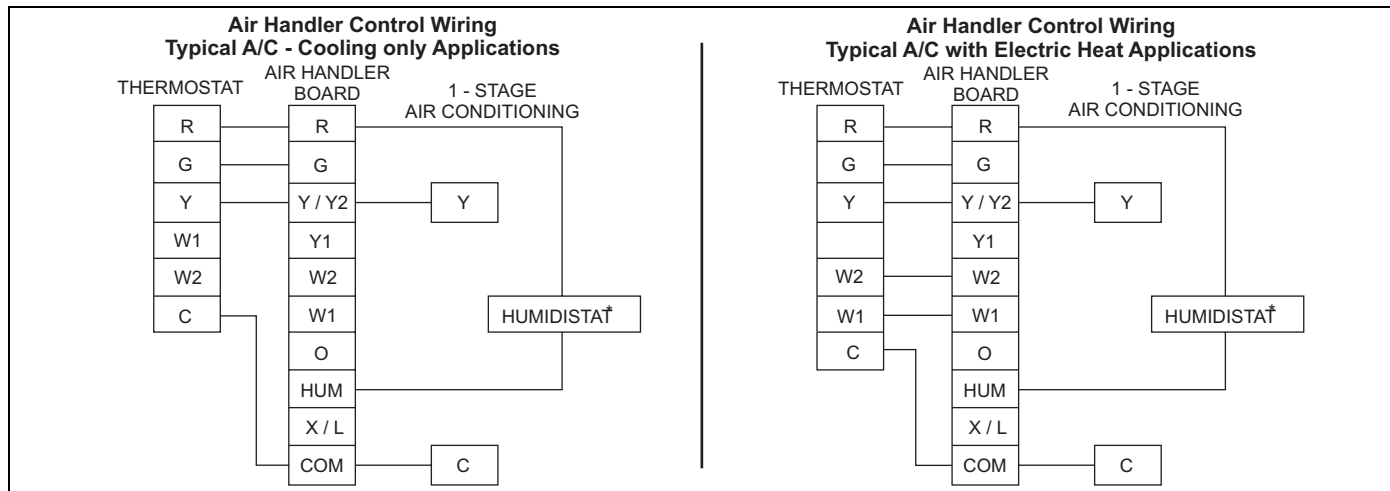

CONTROL WIRING

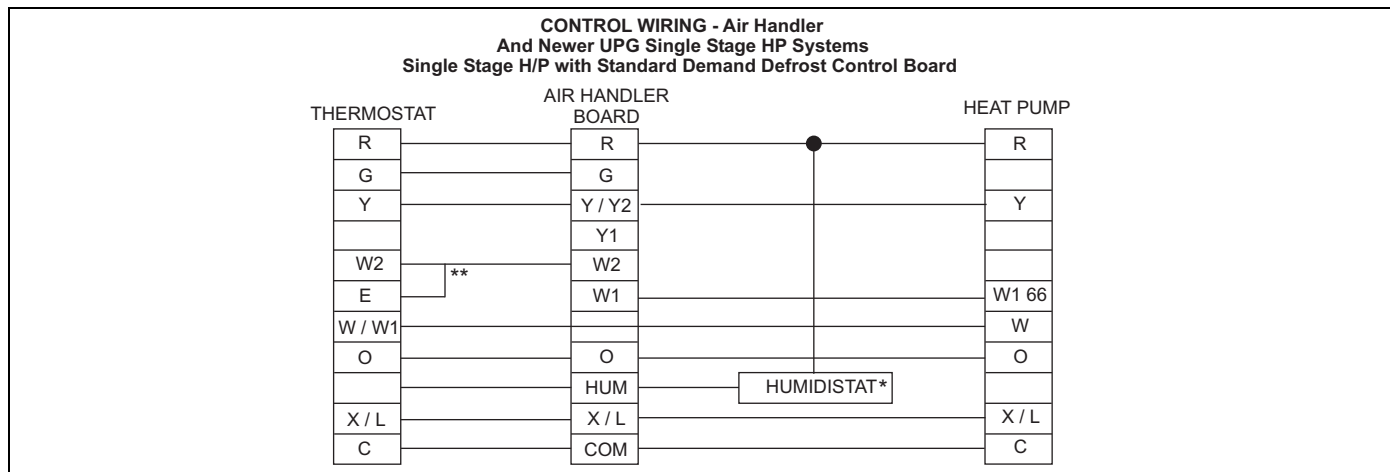

* Optional dehumidification humidistat switch contacts open on rise.
 ** Maybe required.

Note: Not applicable to 115 volt models.

1. "Y" Terminal on Air Handler Control Board must be connected for full CFM and applications requiring 60 second blower off delay for SEER enhancement.

2. Move HUM STAT Jumper on AH Control Board to YES position if Humidistat is used.

3. MODE Jumper on AH control board should be set to HP for heat pumps.

4. To change quantity of heat during HP defrost cycle - Reverse connections at W1 & W2 on Air Handler Control Board.

TYPICAL APPLICATIONS WITH MC MULTI-POSITION COILS

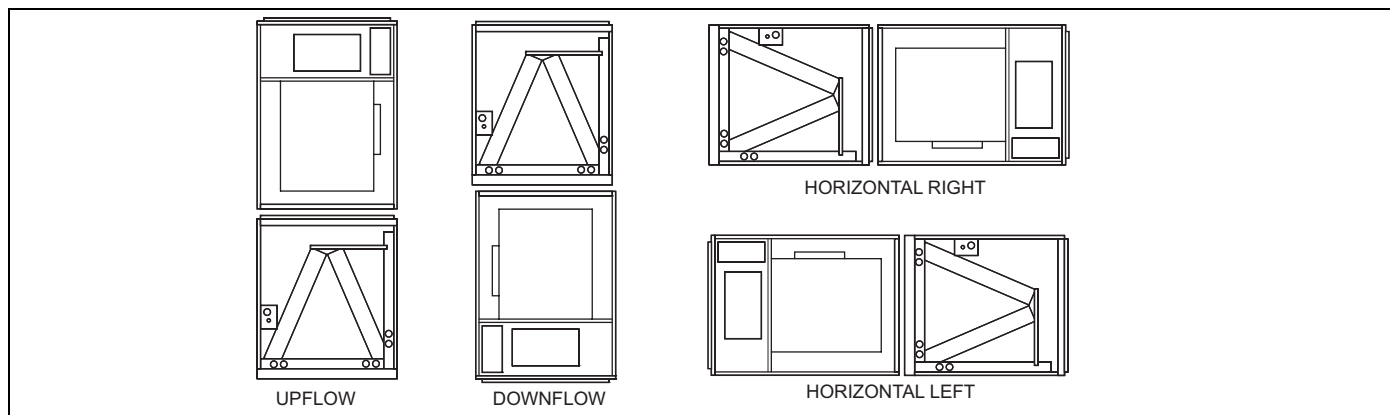

NOTES