

INSTALLATION MANUAL

MODULAR NON-VARIABLE SPEED AIR HANDLERS

MODELS: MA

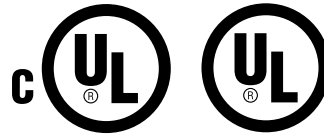

LIST OF SECTIONS

GENERAL	1	REQUIRED CONTROL SET-UP	6
SAFETY	1	LINE POWER CONNECTIONS	7
UNIT INSTALLATION	2	BLOWER SPEED CONNECTIONS	8
ELECTRIC HEATER INSTALLATION	5	UNIT DATA	9
LOW VOLTAGE CONTROL CONNECTIONS	5	MAINTENANCE	15

LIST OF FIGURES

Typical Installation with MC or FC Evaporator Coil	3	460V - Line Power Connections	8
Coil and Air Handler Attachment Details	3	Blower Speed Connections	8
Dimensions & Duct Connection Dimensions	4	460V - Blower Speed Connections	8
Typical Horizontal Installation	5	Cooling Models with Electric Heat Wiring	15
Control Board	5	Two-Stage Cooling Wiring	15
Line Power Connections	8		

LIST OF TABLES

Dimensions	4	Electrical Data - (For Single Source Power Supply) - Copper Wire 1 Ø - 208/230-1-60	11
Low Voltage Connections	6	Electrical Data - 3 Ø - 208/230-3-60	11
Fault Codes	6	Electrical Data - (For Multi-Source Power Supply) - Copper Wire 3 Ø - 208/230-3-60	12
Low Fan Control Inputs	7	Electrical Data - (For Single Source Power Supply) - Copper Wire 3 Ø - 208/230-3-60	12
Blower Delays	7	Electrical Data - 460-3-60	12
Heat Relays	7	Electrical Data - (For Single Source Power Supply) - Copper Wire 3 Ø - 460-3-60	12
Physical and Electrical Data	9	Air Flow Data - 60 Hz Models (230 & 460 Volt)	13
Electrical Data - Cooling Only (60 Hz) - 208/230	9	Air Flow Data - 60 Hz Models (208 Volt)	14
Electrical Data - Cooling Only (60 Hz) - 460	9		
Conversion Table	9		
Electrical Data - 1 Ø - 208/230-1-60	10		
Electrical Data - (For Multi-Source Power Supply) - Copper Wire 1 Ø - 208/230-1-60	10		

SECTION I: GENERAL

This modular air handler provides the flexibility for installation in any upflow, downflow, or horizontal application. These versatile models may be used for cooling or heat pump operation with or without electric heat.

A BRAND LABEL (available from Distribution) may be applied to the center of the blower access panel.

The unit can be positioned for bottom return air in the upflow position, top return air in the downflow position, and right or left return in the horizontal position.

Top and side power wiring and control wiring, accessible screw terminals for control wiring and easy to install electric heaters all combine to make the installation easy, and minimize installation cost.

SECTION II: SAFETY



This is a safety alert symbol. When you see this symbol on labels or in manuals, be alert to the potential for personal injury.

Understand and pay particular attention to the signal words **DANGER**, **WARNING**, or **CAUTION**.

DANGER indicates an **imminently** hazardous situation, which, if not avoided, **will result in death or serious injury**.

WARNING indicates a **potentially** hazardous situation, which, if not avoided, **could result in death or serious injury**.

CAUTION indicates a potentially hazardous situation, which, if not avoided **may result in minor or moderate injury**. It is also used to alert against unsafe practices and hazards involving only property damage.

WARNING

Improper installation may create a condition where the operation of the product could cause personal injury or property damage.

Improper installation, adjustment, alteration, service or maintenance can cause injury or property damage. Refer to this manual for assistance or for additional information, consult a qualified contractor, installer or service agency.

CAUTION

This product must be installed in strict compliance with the installation instructions and any applicable local, state, and national codes including, but not limited to building, electrical, and mechanical codes.

WARNING**FIRE OR ELECTRICAL HAZARD**

Failure to follow the safety warnings exactly could result in serious injury, death or property damage.

A fire or electrical hazard may result causing property damage, personal injury or loss of life.

1. Install this air handler only in a location and position as specified in SECTION III of these instructions.
2. Always install the air handler to operate within the air handler's intended maximum outlet air temperature. Only connect the air handler to a duct system which has an external static pressure within the allowable range, as specified on the air handler rating plate.
3. When an air handler is installed so that supply ducts carry air circulated by the air handler to areas outside the space containing the air handler, the return air shall also be handled by duct(s) sealed to the air handler casing and terminating outside the space containing the air handler.
4. The air handler is not to be used for temporary heating of buildings or structures under construction.
5. The size of the unit should be based on an acceptable heat loss or gain calculation for the structure. ACCA, Manual J or other approved methods may be used.

SAFETY REQUIREMENTS

1. This air handler should be installed in accordance with all national and local building/safety codes and requirements, local plumbing or wastewater codes, and other applicable codes.
2. Refer to the unit rating plate for the air handler model number, and then see the dimensions page of this instruction for supply air plenum dimensions in Figure 3. The plenum must be installed according to the instructions.
3. Provide clearances from combustible materials as listed under Clearances to Combustibles.
4. Provide clearances for servicing ensuring that service access is allowed for electric heaters and blower.
5. Failure to carefully read and follow all instructions in this manual can result in air handler malfunction, death, personal injury and/or property damage.
6. Check the rating plate and power supply to be sure that the electrical characteristics match.
7. Air handler shall be installed so the electrical components are protected from water.
8. Installing and servicing heating/cooling equipment can be hazardous due to the electrical components. Only trained and qualified personnel should install, repair, or service heating/cooling equipment. Untrained service personnel can perform basic maintenance functions such as cleaning and replacing the air filters. When working on heating/cooling equipment, observe precautions in the manuals and on the labels attached to the unit and other safety precautions that may apply.
9. These instructions cover minimum requirements and conform to existing national standards and safety codes. In some instances these instructions exceed certain local codes and ordinances, especially those who have not kept up with changing residential and non-HUD modular home construction practices. These instructions are required as a minimum for a safe installation.

INSPECTION

As soon as a unit is received, it should be inspected for possible damage during transit. If damage is evident, the extent of the damage should be noted on the carrier's freight bill. A separate request for inspection by the carrier's agent should be made in writing. Also, before installation the unit should be checked for screws or bolts, which may have loosened in transit. There are no shipping or spacer brackets which need to be removed.

Also check to be sure all accessories such as heater kits, suspension kits, and coils are available. Installation of these accessories or field conversion of the unit should be accomplished before setting the unit in place or connecting any wiring, electric heat, ducts or piping.

LIMITATIONS

These units must be wired and installed in accordance with all national and local safety codes.

Voltage limits are as follows:

Air Handler Voltage	Voltage code	¹ Normal Operating Voltage Range
208/230-1-60	21	187-253
460-3-60	41	432-504

1. Rated in accordance with ARI Standard 110, utilization range "A".

Airflow must be within the minimum and maximum limits approved for electric heat, evaporator coils and outdoor units.

Entering Air Temperature Limits			
Wet Bulb Temp. °F		Dry Bulb Temp. °F	
Min.	Max.	Min.	Max.
57	72	65	95

SECTION III: UNIT INSTALLATION**CLEARANCES**

Clearances must be taken into consideration, and provided for as follows:

1. Refrigerant piping and connections - minimum 12" recommended.
2. Maintenance and servicing access - minimum 36" from front of unit recommended for blower motor / coil replacement.
3. Condensate drain lines routed to clear filter and panel access.
4. Filter removal - minimum 36" recommended.
5. A combustible floor base accessory is available for downflow applications of this unit, if required by local code.

LOCATION

Location is usually predetermined. Check with owner's or dealer's installation plans. If location has not been decided, consider the following in choosing a suitable location:

1. Select a location with adequate structural support, space for service access, clearance for air return and supply duct connections.
2. Use hanging brackets to wall mount unit as shown.
3. Normal operating sound levels may be objectionable if the air handler is placed directly over some rooms such as bedrooms, study, etc.
4. Select a location that will permit installation of condensate line to an open drain or outdoors allowing condensate to drain away from structure.
5. When an evaporator coil is installed in an attic or above a finished ceiling, an auxiliary drain pan should be provided under the air handler as is specified by most local building codes.
6. Proper electrical supply must be available.

NOTE: In severe high humidity, high temperature indoor unit environments, seal completely with adequate fiberglass insulation using vapor barrier on the outside.

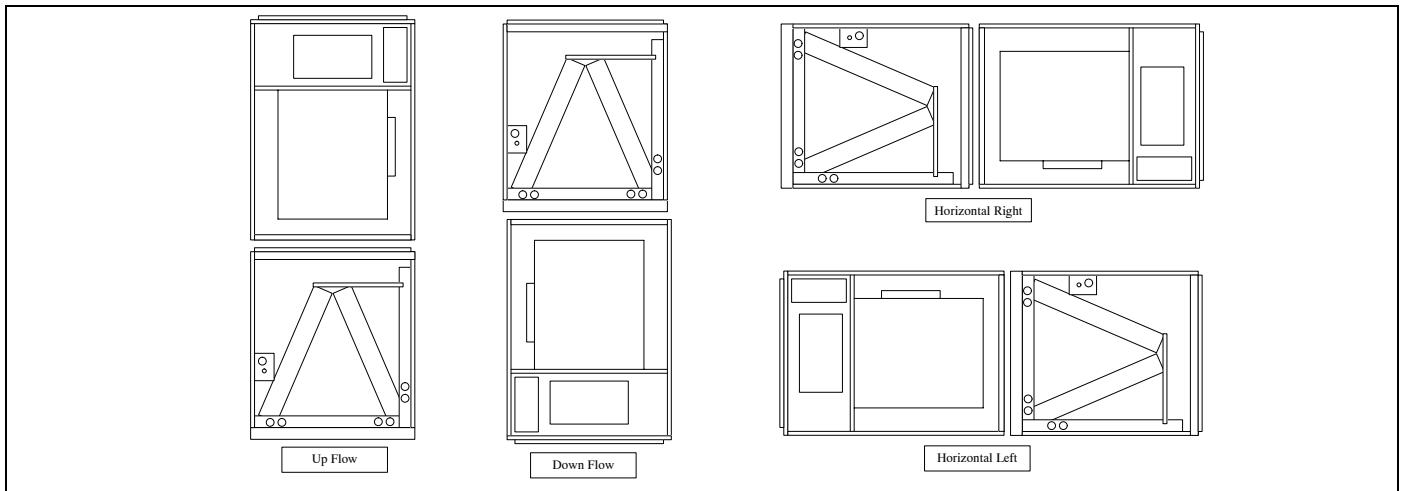

FIGURE 1: Typical Installation with MC or FC Evaporator Coil

DOWNFLOW AND HORIZONTAL CONVERSION

These air handler units are supplied ready to be installed in a upflow, downflow and left or right hand horizontal position.

If the unit is to be installed with an evaporator coil, refer to Figure 1 for unit positioning information.

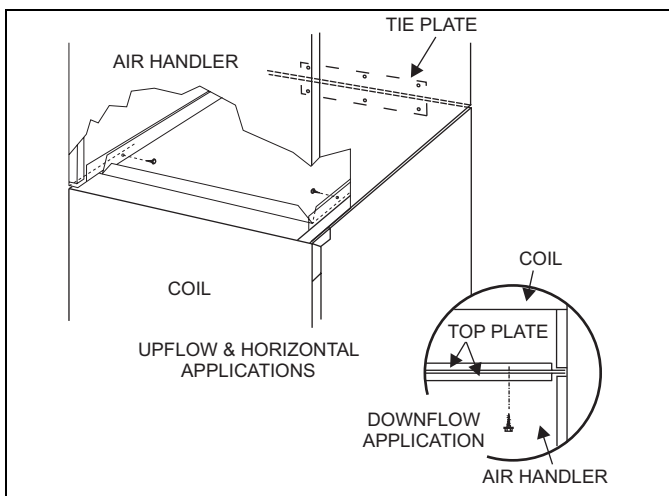

FIGURE 2: Coil and Air Handler Attachment Details

AIR HANDLER AND COIL UPFLOW AND HORIZONTAL INSTRUCTIONS

1. Apply neoprene gasket to top of coil.
 2. Position blower casing over coil opening.
- NOTE:** Tie plate and screws are provided with coils.
3. Attach tie plate to casings of air handler and coil using screws.
 4. Remove blower access panel.
 5. Fasten duct flanges of coil to duct flanges of air handler with screws. See Figure 2.
 6. Secure base of air handler to top of coil using screws.
 7. Complete electrical and blower speed connections as outlined in other sections of this document.
 8. Reposition and replace blower access panel.

AIR HANDLER AND COIL DOWNFLOW INSTRUCTIONS

1. Position blower casing over duct connection and secure such that the supply air end of the blower is down.
 2. Apply neoprene gasket to return-air side of air handler.
 3. Place coil casing over blower return opening.
- NOTE:** Tie plate and screws are provided with coils.
4. Attach tie plate to casings of air handler and coil using screws.
 5. Remove blower access panel and coil filter door.
 6. Fasten duct flanges of coil to base of air handler with screws. See Figure 2.
 7. Secure base of air handler to base of coil using screws.
 8. Complete electrical and blower speed connections as outlined in other sections of this document.
 9. Reposition and replace blower access panel.

CAUTION

Blowers with an electric heater kit may require a non-combustible floor base if installing on a combustible floor. See instructions for 1FB1817, 1FB1821, & 1FB1824, and local codes.

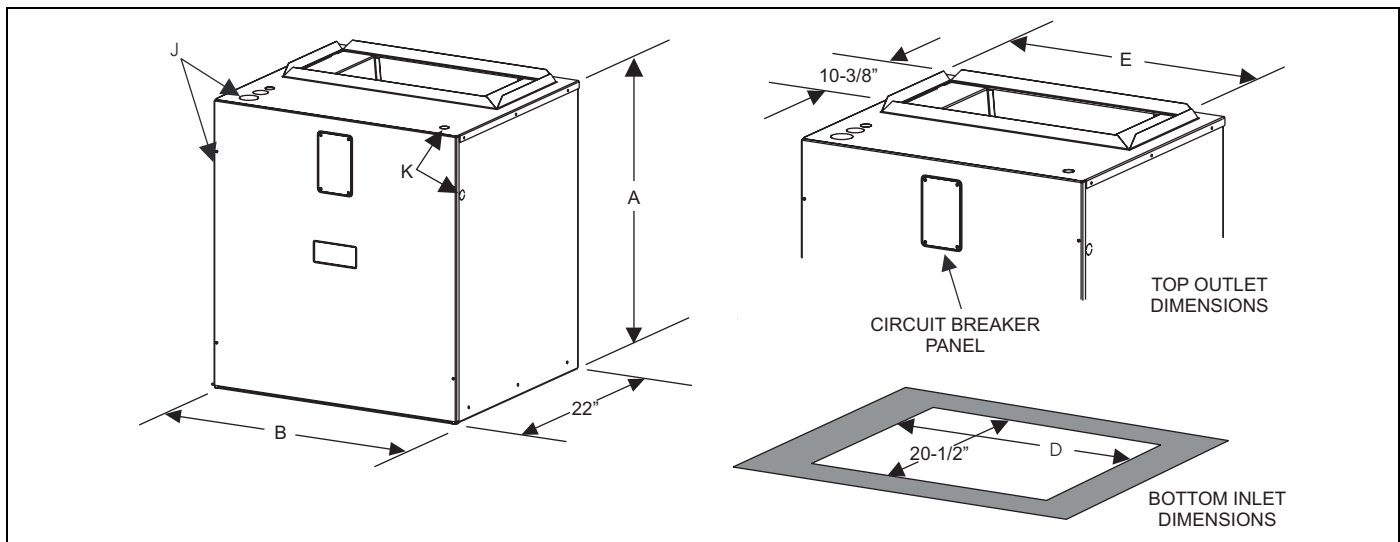

FIGURE 3: Dimensions & Duct Connection Dimensions

TABLE 1: Dimensions

MA MODELS	Dimensions				Wiring Knockouts ¹	
	A	B	D	E	J	K
	Height	Width			Power	Control
08B	25	17-1/2	16-1/2	14-19/32	7/8" (1/2") 1 3/8" (1") 1 23/32" (1 1/4")	7/8" (1/2")
12B		17-1/2	16-1/2	14-19/32		
14D		24-1/2	23-1/2	21-19/32		
16C		21	20	18-3/32		
20D		24-1/2	23-1/2	21-19/32		

1. Actual size (Conduit size).

DUCT CONNECTORS

▲ WARNING

Use 1/2" screws to connect ductwork to bottom of unit. Longer screws will pierce the drain pan and cause leakage. If pilot holes are drilled, drill only through field duct and unit bottom flange.

Air supply and return may be handled in one of several ways best suited to the installation. See Figure 3 for dimensions for duct inlet and outlet connections.

The vast majority of problems encountered with combination heating and cooling systems can be linked to improperly designed or installed duct systems. It is therefore highly important to the success of an installation that the duct system be properly designed and installed.

Use flexible duct collars to minimize the transmission of vibration/noise into the conditioned space. If electric heat is used, non-flammable material must be used.

Where return air duct is short, or where sound may be a problem, sound absorbing glass fiber should be used inside the duct. Insulation of duct work is a must where it runs through an unheated space during the heating season or through an uncooled space during the cooling season. The use of a vapor barrier is recommended to prevent absorption of moisture from the surrounding air into the insulation.

The supply air duct should be properly sized by use of a transition to match unit opening. All ducts should be suspended using flexible hangers and never fastened directly to the structure. This unit is not designed for non-ducted (freeblow) applications. Size outlet plenum or transition to discharge opening sizes shown in Figure 3.

Duct work should be fabricated and installed in accordance with local and/or national codes. This includes the standards of the National Fire Protection Association for Installation of Air-Conditioning and Ventilating Systems, NFPA No. 90B.

AIR FILTERS

Air filters and filter racks must be field supplied.

▲ CAUTION

Equipment should never be operated without filters.

SUSPENSION KITS

A suspension kit is available. Models 1BH0601 (unit size 018-060) is designed specifically for the units contained in this instruction (upflow application only). For installation of these accessory kits, see the instructions packed with the kit.

HORIZONTAL SUSPENSION

For suspension of these units in horizontal applications, it is recommended to use angle steel support brackets with threaded rods, supporting the units from the bottom, at the locations shown in Figure 4.

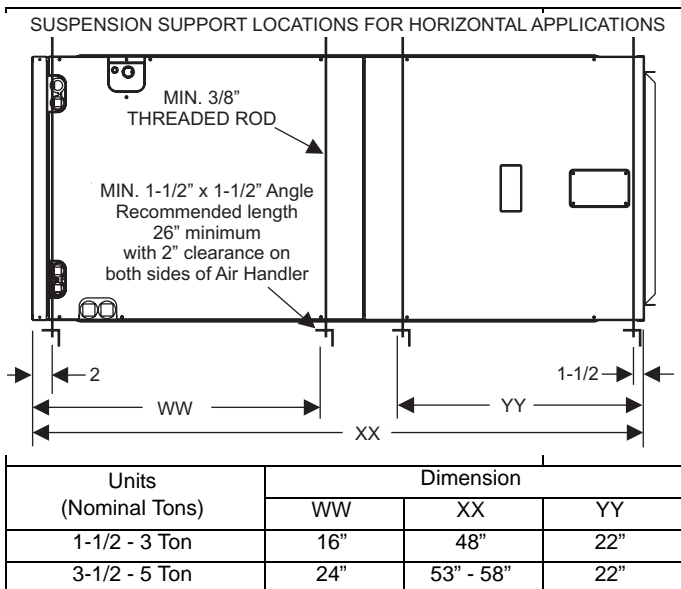

FIGURE 4: Typical Horizontal Installation

SECTION IV: ELECTRIC HEATER INSTALLATION

If the air handler requires electric heat, install the electric heat kit according to the installation instructions included with the kit. After installing the kit, mark the air handler nameplate to designate the heater kit that was installed. If no heater is installed, mark the name plate appropriately to indicate that no heat kit is installed.

The HEAT ENABLE jumper (See Figure 5) must be moved to the HEAT position to enable operation of the heater.

Use only 4HK heater kits, as listed on Air Handler name plate and in these Instructions. Use data from Tables 11 through 18 for information on required minimum motor speed tap to be used for heating operation, maximum over-current protection device required and minimum electrical supply wiring size required for listed combination of Air Handler and Heater Kit.

For Upflow, Downflow and Horizontal right hand applications the kits can be installed without modification.

Field modification is required for Horizontal left-hand airflow application only. Follow instructions with heater for modification.

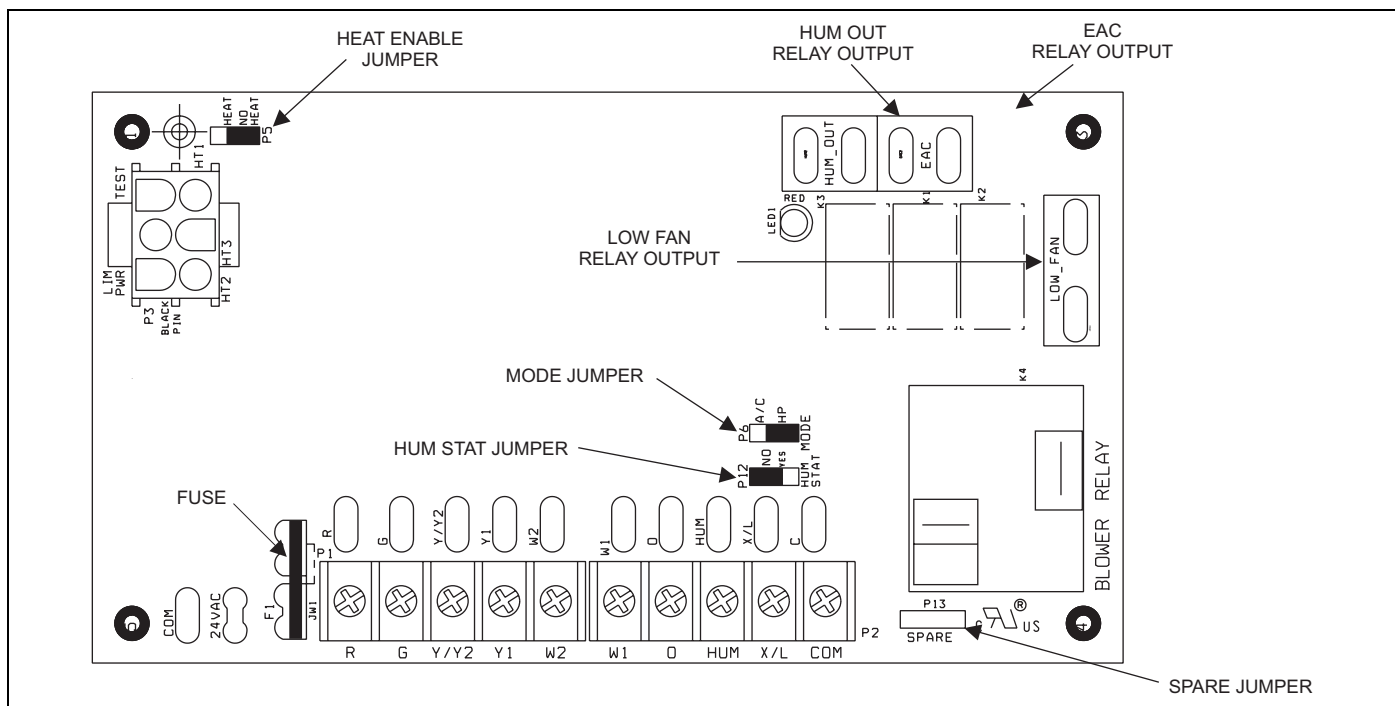

FIGURE 5: Control Board

SECTION V: LOW VOLTAGE CONTROL CONNECTIONS

The 24 volt power supply is provided by an internally wired low voltage transformer which is standard on all models. However, if the unit is connected to a 208 volt power supply, the low voltage transformer must be rewired to the 208 volt tap. See the unit wiring label.

Field supplied low voltage wiring can exit the unit on the top right hand corner or the right hand side panel. Refer to Figure 3.

Remove desired knockout and pierce foil faced insulation to allow wiring to pass through. Use as small of a hole as possible to minimize air leakage.

Install a 7/8" plastic bushing in the selected hole and keep low voltage wiring as short as possible inside the control box.

To further minimize air leakage, seal the wiring entry point at the outside of the unit.

The field wiring is to be connected at the screw terminals of the control board. Refer to Figures 10 & 11.

NOTE: All wiring must comply with local and national electrical code requirements. Read and heed all unit caution labels.

NOTE: It is possible to vary the amount of electric heat turned on during the defrost cycle of a heat pump. Standard wiring will only bring on the first stage of electric heat during defrost. See Heat Output and Limit Connections and Table 6 for additional information on heat during defrost cycle.

TABLE 2: Low Voltage Connections

Terminal	Signal	Comment
R	24 VAC power (fused)	
G	Continuous Fan operation	
Y/Y2	Second or full stage compressor operation	
Y1	First stage compressor operation	Not used with outdoor units having one stage compressors.
W2	Second stage heat operation	
W1	First stage heat operation	
O	Reversing valve operation	24 VAC will be present at this terminal when the MODE jumper is in the AC position. This is normal.
HUM	Humidity switch input	24 VAC will be present at this terminal when the HUM STAT jumper is in the NO position. This is normal.
X/L	Connection point for heat pump fault indicator	This terminal is a connection point only and does not affect air handler control operation.
COM	24 VAC common	

The low voltage connections may be connected to the screw terminals or the quick connect terminals. The screw terminals and the quick connect terminals are physically connected on the control board.

HUMIDITY SWITCH INPUT

The air handler control is designed to work with a humidity control that closes when the humidity is below the set-point. The control is open when the humidity is above the set-point. This humidity control may be referred to as a humidistat or a dehumidistat.

The humidity switch controls both humidification and de-humidification operation of the control. The control provides humidification using the HUM OUT relay output and de-humidification by lowering the blower speed. This is accomplished using the LOW FAN output and a field installed two-speed fan relay kit for non-variable speed models and the de-humidification input of the motor for variable speed models. The humidity switch should be connected to the R and HUM terminals of the control. See Figures 10 & 11.

SECTION VI: REQUIRED CONTROL SET-UP

IMPORTANT: The following steps must be taken at the time of installation to insure proper system operation.

1. Consult system wiring diagram to determine proper thermostat wiring for your system.
2. If heat kit is installed, change HEAT ENABLE jumper from NO HEAT to HEAT position.
3. If a humidistat is installed, change HUM STAT jumper from NO to YES.
4. Set the MODE jumper to A/C (Air Conditioner) or HP (Heat Pump) position depending on the outdoor unit included with the system.

FUNCTIONALITY AND OPERATION

Jumper Positions

Heat Enable Jumper

The HEAT ENABLE jumper configures the control for heat kit operation. The jumper must be in the HEAT position if a heat kit is installed with the air handler.

With the jumper in the NO HEAT position, the control will not energize the heat relay outputs or sense the limit switch input.

If the jumper is not present, the control will operate as if the jumper is in the HEAT position. If the jumper is not present and a heat kit is not present, the control will sense an open limit condition and the blower will run continuously.

Hum Stat Jumper

The HUM STAT jumper configures the control to monitor the humidity switch input. With the jumper in the NO position, the control will energize the HUM terminal with 24 VAC continually. With the jumper in the YES position, the control will monitor the HUM input to control the HUM OUT output to control an external humidifier.

If the jumper is not present, the control will operate as if the jumper is in the YES position.

Mode Jumper

The MODE jumper configures the control to operate properly with an air conditioner (AC position) or heat pump (HP position). With the jumper in the AC position, the control will energize the O terminal with 24 VAC continually. With the jumper in the HP position, the O input signal is received from the room thermostat.

If the jumper is not present, the control will operate as if the jumper is in the HP position.

SPARE Jumper

The control includes a spare jumper that can be used if a jumper is lost. The SPARE jumper does not have any effect on the operation of the control.

Status and Fault Codes

The control includes an LED that displays status and fault codes. These codes are shown in Table 3. The control will display the fault codes until power is removed from the control or the fault condition is no longer present.

TABLE 3: Fault Codes

Fault or Status Condition	LED1 (RED) Flash Code
Status	
No power to control	OFF
Normal operation	2s ON / 2s OFF
Control in test mode	Rapid Flash
Control failure	ON
Limit Faults	
Limit switch currently open (not in lockout)	1
Multiple limit openings with no call for heat	2
Multiple limit openings during one call for heat	3
Single long duration limit opening	4
Multiple long duration limit openings	5
Fan failure	6
Wiring Related Faults	
Simultaneous call for heating and cooling	7
Internal Control Faults	
Control recovered from internal event	9

External Relay Outputs

The control includes three outputs to drive external relays having 24 VAC coils. The outputs have a maximum rating of 1.0 Amp pilot duty at 24 VAC.

HUM OUT

The HUM OUT output can be used to drive an external relay or solenoid (24 VAC coil) to control a humidifier. The output is energized when the HUM input is energized, the HUM STAT is in the YES position, and the control has a thermostat call for heating (heat pump or electric heat).

EAC

The EAC output can be used to drive an external relay (24 VAC coil) to control an electronic air cleaner. The output is energized whenever the blower relay on the control is energized. Models having a high efficiency non-variable speed motor use the EAC output as an input to the motor. The EAC output can also be used to drive an electronic air cleaner relay as long as the load of the EAC relay does not exceed 1.0 Amp. An additional connection to the EAC terminals must be made using a piggyback terminal or similar device.

LOW FAN

The LOW FAN output can be used to drive an external relay (24 VAC coil) that switches the power input to the motor to a lower speed tap. An accessory kit is available for this application.

The LOW FAN output is energized when the control has the following inputs.

TABLE 4: Low Fan Control Inputs

Input	Operational Mode
G	Continuous Fan operation
Y1 or Y1 and O	First stage compressor operation
Y/Y2 and HUM de-energized with HUM STAT jumper in YES position	Dehumidification during cooling

Blower Delays

The control includes the following blower delays:

TABLE 5: Blower Delays

Condition	Blower Delay
Following call for cooling	60 seconds
Following call for heat pump heating	30 seconds
Following call for electric heat heating	10 seconds

Heat Output and Limit Connections

The control is connected to the heater relays and limit switch using the 6-pin connector. The relay outputs and the limit switch signal are 24 VDC.

The control energizes the heat relays and senses the limit switch input as shown in Table 6 when the HEAT ENABLE jumper is in the HEAT position.

TABLE 6: Heat Relays

Input	Heat Relay Output
W1	HT1
W2	HT1 and HT2
W1 and W2	HT1 and HT2 and HT3

The control energizes the first stage of electric heat immediately, the second stage 10 seconds after the call for second stage heat, and the third stage 20 seconds after the call for third stage heat.

Depending on the heat kit installed in the air handler, the control provides the flexibility to configure the amount of heat delivered with the first stage heating call. As an example, when the control's W1 input is connected to the room thermostat's first stage heat signal, a call for first stage heat will energize one heating element (HT1). If the control's W2 input is connected to the room thermostat's first stage heat signal, a call for first stage heat will energize two heating elements (HT1 & HT2). With either configuration, the control will energize three heating elements (HT1, HT2, & HT3) when it receives a first and second stage heat input from the thermostat.

Limit Switch and Lockout Operation

Limit Switch Operation

If the HEAT ENABLE jumper is in the HEAT position and the limit switch opens (fault code 1), the control will immediately de-energize all electric heat relay outputs and energize the blower (if it wasn't already energized). When the limit switch closes, the control will re-energize electric heat according to the thermostat inputs using normal timings.

Fan On Lock Condition

If the limit switch opens multiple times during a single call for electric heat (fault code 3) or if the limit switch opens for a long duration (fault code 4), the control will energize the blower until power is removed from the control. The control will cycle the heat outputs on and off as the limit re-closes and opens. The constant fan operation will signal the homeowner that a problem has occurred and a service call is required.

Soft Lockout

If the limit switch opens for a second long duration period during a single call for heat (fault code 5), the control will keep the blower locked on and lock out the heat outputs for one hour. The control will only reset this one hour lockout when the power is removed from the control. After the one hour period has passed, the control will re-energize electric heat according to the thermostat inputs using normal timings. The blower will remain locked on from the first long duration limit opening.

Hard Lockout

The control has a hard lockout condition during which the control will keep all heat outputs de-energized until power is removed from the control. The control de-energizes the blower five minutes after entering the hard lockout condition.

If the limit switch closes and re-opens during the one hour soft lockout period, the control will enter a hard lockout condition and continue to indicate a fault code 5.

If the limit switch opens twice when no call for electric heat is present (fault code 2), the control will enter a hard lockout condition.

If the limit switch opens multiple times soon after a soft lockout reset (fault code 6), the control will enter a hard lockout condition.

Wiring Related Faults

If the control receives a simultaneous call for heating and cooling (fault code 7), the control will perform both heating and cooling operations.

SECTION VII: LINE POWER CONNECTIONS

Power may be brought into the unit through the supply air end of the unit (top when unit is vertical) or the left side panel. Use the hole appropriate to the unit's orientation in each installation to bring conduit from the disconnect. The power lead conduit should be terminated at the electrical control box. To minimize air leakage, seal the wiring entry point at the outside of the unit. See Figure 3.

Refer to Tables to determine proper wire sizing:

Tables 8 & 9 for cooling only or,

Tables 12 & 13 for single phase or,

Tables 15 & 16 for three phase or,

Table 18 for 460V.

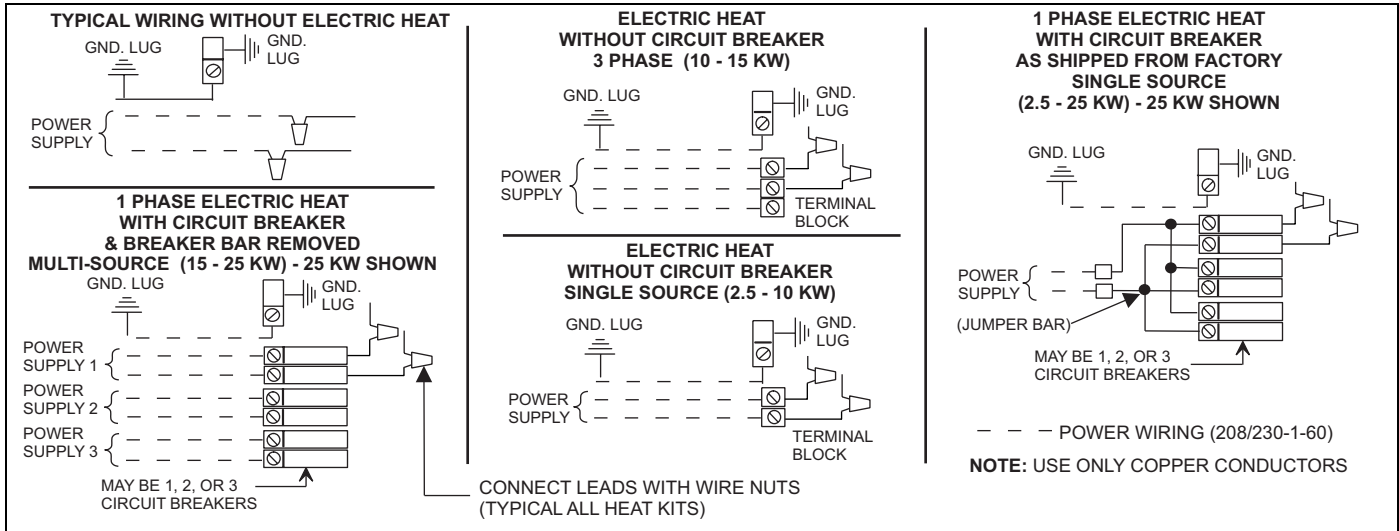

FIGURE 6: Line Power Connections

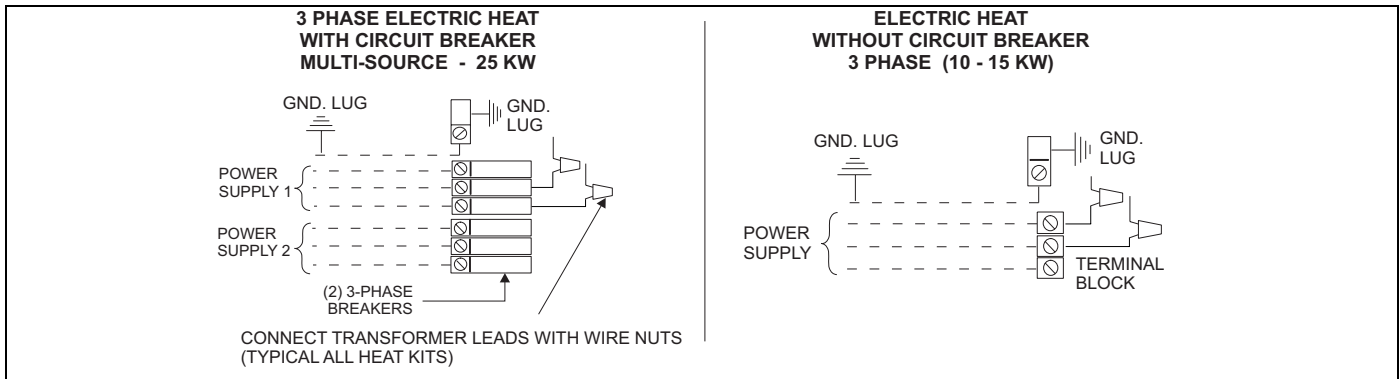

FIGURE 7: 460V - Line Power Connections

SECTION VIII: BLOWER SPEED CONNECTIONS

All air handlers contain 3-speed blower motors which are prewired to the control board.

Adjust blower motor speed to provide airflow within the minimum and maximum limits approved for evaporator coil, electric heat and outdoor unit. Speed tap adjustments are made at the motor terminal block. See Figure 8 or 9. Airflow data is shown in Tables 19 & 20.

Connect motor wires to motor speed tap receptacle for speed desired. See wiring label for motor wiring details.

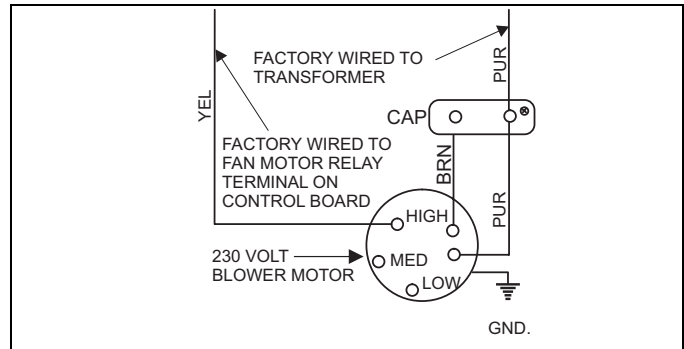

FIGURE 8: Blower Speed Connections

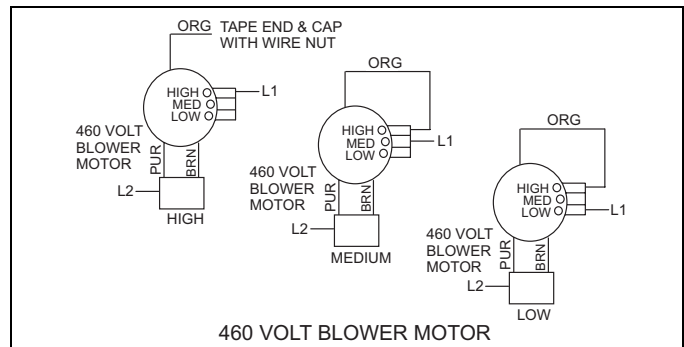

FIGURE 9: 460V - Blower Speed Connections

SECTION IX: UNIT DATA

TABLE 7: Physical and Electrical Data

Models: MA		08B21	12B21	12B41	14D21
Blower - Diameter x Width		10 x 9	10 x 9	10 x 9	10 x 10
Motor	HP	1/4 HP	3/4 HP	3/4 HP	1/2 HP
	Nominal RPM	1075	1075	1075	1075
Voltage		208 / 230	208 / 230	460	208 / 230
Amps	Full Load	1.5	3.5	2.3	2.4
Filter ¹	Type	DISPOSABLE OR PERMANENT			
	Size	16 x 20 x 1	16 x 20 x 1	16 x 20 x 1	22 x 20 x 1
	Permanent Type Kit	1PF0601BK	1PF0601BK	1PF0601BK	1PF0603BK
Filter Rack		1FR0617	1FR0617	1FR0617	1FR0624
Shipping / Operating Weight (lbs.)		128 / 122	132 / 126	132 / 126	162 / 156
Models: MA		16C21	16C41	20D21	20D41
Blower - Diameter x Width		10 x 10	10 x 10	11 x 10	11 x 10
Motor	HP	1 HP	1 HP	1 HP	1 HP
	Nominal RPM	1075	1075	1075	1075
Voltage		208 / 230	460	208 / 230	460
Amps	Full Load	4.0	2.6	7.4	3.7
Filter ¹	Type	DISPOSABLE OR PERMANENT			
	Size	20 x 20 x 1	20 x 20 x 1	22 x 20 x 1	22 x 20 x 1
	Permanent Type Kit	1PF0602BK	1PF0602BK	1PF0603BK	1PF0603BK
Filter Rack		1FR0621	1FR0621	1FR0624	1FR0624
Shipping / Operating Weight (lbs.)		139 / 133	139 / 133	162 / 156	162 / 156

1. Field Supplied.

TABLE 8: Electrical Data - Cooling Only (60 Hz) - 208/230

Models MA	Total Motor Amps		Minimum Circuit Ampacity		Max. O.C.P. ¹ Amps/Type	Minimum Wire Size A.W.G.
	60 Hertz		60 Hertz			
	208V	230V	208V	230V		
08BN21	1.4	1.5	1.8	1.9	15	14
12BN21	2.1	3.5	2.6	3.0	15	14
14DN21	3.3	2.4	4.1	4.4	15	14
16CN21	3.6	4.0	4.5	5.0	15	14
20DN21	4.8	7.4	6.0	6.5	15	14

1. OCP = Over Current Protection device, must be HACR type Circuit Breaker or Time Delay fuse.

TABLE 9: Electrical Data - Cooling Only (60 Hz) - 460

Models MA	Total Motor Amps	Minimum Circuit Ampacity	Max. O.C.P. ¹ Amps/Type	Minimum Wire Size A.W.G.
	60 Hertz	60 Hertz		
12BN41	2.3	3.5	15	14
16CN41	2.6	3.9	15	14
20DN41	3.7	5.6	15	14

1. OCP = Over Current Protection device, must be HACR type Circuit Breaker or Time Delay fuse.

TABLE 10: Conversion Table

KW & MBH Conversions - for Total Power Input Requirement					
FOR	208V	OPERATION MULTIPLY	240V	TABULATED KW & MBH BY	.751
	230V		240V		.918
	220V		240V		.840

TABLE 11: Electrical Data - 1 Ø - 208/230-1-60

Models MA	Heat Kit - Single Phase	Max. Static	Min. Speed Tap	Total Heat ¹				KW Staging					
				KW		MBH		W1 Only		W2 Only		W1 + W2	
				208V	240V	208V	240V	208V	240V	208V	240V	208V	240V
08BN21	4HK*6500206	0.5	Lo	1.9	2.5	6.4	8.5	1.9	2.5	1.9	2.5	1.9	2.5
	4HK*6500506	0.5	Lo	3.6	4.8	12.3	16.4	3.6	4.8	3.6	4.8	3.6	4.8
	4HK*6500806	0.5	Med	5.6	7.5	19.2	25.6	2.8	3.75	5.6	7.5	5.6	7.5
	4HK*6501006	0.5	Hi	7.2	9.6	24.6	32.8	3.6	4.8	7.2	9.6	7.2	9.6
12BN21	4HK*6500506	0.5	Lo	3.6	4.8	12.3	16.4	3.6	4.8	3.6	4.8	3.6	4.8
	4HK*6500806	0.5	Med	5.6	7.5	19.2	25.6	2.8	3.75	5.6	7.5	5.6	7.5
	4HK*6501006	0.5	Med	7.2	9.6	24.6	32.8	3.6	4.8	7.2	9.6	7.2	9.6
	4HK165N1506	0.5	Med	10.8	14.4	36.9	49.1	3.6	4.8	7.2	9.6	10.8	14.4
14DN21	4HK*6500506	0.5	Lo	3.6	4.8	12.3	16.4	3.6	4.8	3.6	4.8	3.6	4.8
	4HK*6500806	0.5	Lo	5.6	7.5	19.2	25.6	2.8	3.75	5.6	7.5	5.6	7.5
	4HK*6501006	0.5	Med	7.2	9.6	24.6	32.8	3.6	4.8	7.2	9.6	7.2	9.6
	4HK16501506	0.5	Med	10.8	14.4	36.9	49.1	3.6	4.8	7.2	9.6	10.8	14.4
	4HK16501806	0.5	Hi	13.2	17.6	45.1	60.1	3.3	4.4	6.6	8.8	13.2	17.6
	4HK16502006	0.5	Hi	14.4	19.2	49.2	65.5	3.6	4.8	7.2	9.6	14.4	19.2
16CN21	4HK*6500506	0.5	Lo	3.6	4.8	12.3	16.4	3.6	4.8	3.6	4.8	3.6	4.8
	4HK*6500806	0.5	Lo	5.6	7.5	19.2	25.6	2.8	3.75	5.6	7.5	5.6	7.5
	4HK*6501006	0.5	Med	7.2	9.6	24.6	32.8	3.6	4.8	7.2	9.6	7.2	9.6
	4HK16501506	0.5	Med	10.8	14.4	36.9	49.1	3.6	4.8	7.2	9.6	10.8	14.4
	4HK16501806	0.5	Hi	13.2	17.6	45.1	60.1	3.3	4.4	6.6	8.8	13.2	17.6
	4HK16502006	0.5	Hi	14.4	19.2	49.2	65.5	3.6	4.8	7.2	9.6	14.4	19.2
20DN21	4HK*6500806	0.5	Lo	5.6	7.5	19.2	25.6	2.8	3.75	5.6	7.5	5.6	7.5
	4HK*6501006	0.5	Lo	7.2	9.6	24.6	32.8	3.6	4.8	7.2	9.6	7.2	9.6
	4HK16501506	0.5	Med	10.8	14.4	36.9	49.1	3.6	4.8	7.2	9.6	10.8	14.4
	4HK16501806	0.5	Med	13.2	17.6	45.1	60.1	3.3	4.4	6.6	8.8	13.2	17.6
	4HK16502006	0.5	Med	14.4	19.2	49.2	65.5	3.6	4.8	7.2	9.6	14.4	19.2
	4HK16502506	0.5	Med	18.0	24.0	61.5	81.9	3.6	4.8	10.8	14.4	18.0	24.0

1. See conversion Table 10.

* May be 0 (no breaker) or 1 (with breaker).

TABLE 12: Electrical Data - (For Multi-Source Power Supply) - Copper Wire 1 Ø - 208/230-1-60

Models MA	Heater Model	Min. Circuit Ampacity			Max. O.C.P. ¹ Amps/Type			75°C Wire Size - AWG		
		Circuit			Circuit			Circuit		
		1st	2nd	3rd	1st	2nd	3rd	1st	2nd	3rd
		208/240	208/240	208/240	208/240	208/240	208/240	208/240	208/240	208/240
12BN21	4HK165N1506	47.5 / 54.4	21.7 / 25.0	–	50 / 60	25 / 25	–	8 / 6	10 / 10	–
14DN21	4HK16501506	46.0 / 53.0	21.7 / 25.0	–	50 / 60	25 / 25	–	8 / 6	10 / 10	–
	4HK16501806	42.3 / 48.8	39.7 / 45.8	–	45 / 50	40 / 50	–	8 / 8	8 / 8	–
	4HK16502006	46.0 / 53.0	43.3 / 50.0	–	50 / 60	45 / 50	–	8 / 6	8 / 8	–
16CN21	4HK16501506	47.8 / 55.0	21.7 / 25.0	–	50 / 60	25 / 25	–	8 / 6	10 / 10	–
	4HK16501806	44.2 / 50.8	39.7 / 45.8	–	50 / 60	40 / 50	–	8 / 6	8 / 8	–
	4HK16502006	47.8 / 55.0	43.3 / 50.0	–	50 / 60	45 / 50	–	8 / 6	8 / 8	–
20DN21	4HK16501506	49.3 / 56.5	21.7 / 25.0	–	50 / 60	25 / 25	–	8 / 6	10 / 10	–
	4HK16501806	45.7 / 52.3	39.7 / 45.8	–	50 / 60	40 / 50	–	8 / 6	8 / 8	–
	4HK16502006	49.3 / 56.5	43.3 / 50.0	–	50 / 60	45 / 50	–	8 / 6	8 / 8	–
	4HK16502506	49.3 / 56.5	43.3 / 50.0	21.7 / 25.0	50 / 60	45 / 50	25 / 25	8 / 6	8 / 8	10 / 10

1. O.C.P. = Over Current Protection device, must be HACR type Circuit Breaker or Time Delay fuse.

TABLE 13: Electrical Data - (For **Single Source** Power Supply) - Copper Wire 1 Ø - 208/230-1-60

Models MA	Heat Kit - Single Phase*	Heater Amps 240V	Field Wiring					
			Min. Circuit Ampacity		Max. O.C.P. ¹ Amps/Type		75°C Wire Size - AWG	
			208V	240V	208V	240V	208V	240V
08BN21	4HK*6500206	10.4	13.03	14.88	15	15	14	14
	4HK*6500506	20.0	23.42	26.88	30	30	10	10
	4HK*6500806	31.3	35.60	41.00	40	45	8	8
	4HK*6501006	40.0	45.08	51.88	50	60	8	6
12BN21	4HK*6500506	20.0	25.79	29.38	30	30	10	10
	4HK*6500806	31.3	37.98	43.50	40	45	8	8
	4HK*6501006	40.0	47.46	54.38	50	60	8	6
	4HK165N1506	60.0	69.13	79.38	70	90	4	3
14DN21	4HK*6500506	20.0	24.29	28.00	30	30	8	10
	4HK*6500806	31.3	36.48	42.13	40	45	8	8
	4HK*6501006	40.0	45.96	53.00	50	60	8	6
	4HK16501506	60.0	67.63	78.00	70	90	4	3
	4HK16501806	73.3	82.07	94.63	90	100	4	3
	4HK16502006	80.0	89.29	103.00	100	110	3	2
16CN21	4HK*6500506	20.0	26.17	30.00	30	30	8	8
	4HK*6500806	31.3	38.35	44.13	40	45	8	8
	4HK*6501006	40.0	47.83	55.00	50	60	8	6
	4HK16501506	60.0	69.50	80.00	70	90	4	3
	4HK16501806	73.3	83.94	96.63	90	100	4	3
	4HK16502006	80.0	91.17	105.00	100	110	3	2
20DN21	4HK*6500806	31.3	42.60	48.38	45	50	8	8
	4HK*6501006	40.0	52.08	59.25	60	60	8	6
	4HK16501506	60.0	73.75	84.25	90	90	3	3
	4HK16501806	73.3	88.19	100.88	90	110	3	2
	4HK16502006	80.0	95.42	109.25	100	125	3	2
	4HK16502506	100.0	117.08	134.25	125	150	1	1/0

1. O.C.P. = Over Current Protection device, must be HACR type Circuit Breaker or Time Delay fuse.

* May be 0 (no breaker) or 1 (with breaker).

TABLE 14: Electrical Data - 3 Ø - 208/230-3-60

Models MA	Heat Kit - Three Phase	Max. Static	Min. Speed Tap	Total Heat ¹				KW Staging					
				KW		MBH		W1 Only		W2 Only		W1 + W2	
				208V	240V	208V	240V	208V	240V	208V	240V	208V	240V
08B	4HK06501025	0.5	Hi	7.2	9.6	24.6	32.8	7.2	9.6	7.2	9.6	7.2	9.6
12B	4HK06501025	0.5	Med	7.2	9.6	24.6	32.8	7.2	9.6	7.2	9.6	7.2	9.6
14D	4HK06501025	0.5	Med	7.2	9.6	24.6	32.8	7.2	9.6	7.2	9.6	7.2	9.6
	4HK06501525	0.5	Med	10.8	14.4	36.9	49.1	10.8	14.4	10.8	14.4	10.8	14.4
	4HK06501825	0.5	Hi	12.9	17.2	44.7	58.7	12.9	17.2	12.9	17.2	12.9	17.2
16C	4HK06501025	0.5	Med	7.2	9.6	24.6	32.8	7.2	9.6	7.2	9.6	7.2	9.6
	4HK06501525	0.5	Med	10.8	14.4	36.9	49.1	10.8	14.4	10.8	14.4	10.8	14.4
	4HK06501825	0.5	Hi	12.9	17.2	44.7	58.7	12.9	17.2	12.9	17.2	12.9	17.2
20D	4HK06501025	0.5	Lo	7.2	9.6	24.6	32.8	7.2	9.6	7.2	9.6	7.2	9.6
	4HK06501525	0.5	Med	10.8	14.4	36.9	49.1	10.8	14.4	10.8	14.4	10.8	14.4
	4HK16502525	0.5	Med	18.0	24.0	61.4	81.4	9.0	12.0	18.0	24.0	18.0	24.0

1. See conversion Table 10.

TABLE 15: Electrical Data - (For **Multi-Source** Power Supply) - Copper Wire 3 Ø - 208/230-3-60

Models MA	Heater Model	Min. Circuit Ampacity			Max. O.C.P. ¹ Amps/Type			75°C Wire Size - AWG		
		Circuit			Circuit			Circuit		
		1st	2nd	3rd	1st	2nd	3rd	1st	2nd	3rd
		208/240	208/240	208/240	208/240	208/240	208/240	208/240	208/240	208/240
20D	4HK16502525	40.0 / 45.4	31.3 / 36.1	- / -	40 / 50	35 / 40	- / -	8 / 8	8 / 8	- / -

1. O.C.P. = Over Current Protection device, must be HACR type Circuit Breaker or Time Delay fuse.

TABLE 16: Electrical Data - (For **Single Source** Power Supply) - Copper Wire 3 Ø - 208/230-3-60

Models MA	Heat Kit - Three Phase	Heater Amps 240V	Field Wiring					
			Min. Circuit Ampacity		Max. O.C.P. ¹ Amps/Type		75°C Wire Size - AWG	
			208V	240V	208V	240V	208V	240V
08B	4HK06501025	23.1	26.8	30.8	30	35	10	8
12B	4HK06501025	23.1	27.6	31.9	30	35	10	8
14D	4HK06501025	23.1	29.1	33.3	30	35	10	8
	4HK06501525	34.7	41.6	46.4	45	50	8	8
	4HK06501825	41.4	48.9	56.1	50	60	8	6
16C	4HK06501025	23.1	29.5	33.9	30	35	10	8
	4HK06501525	34.7	42.0	48.4	45	50	8	8
	4HK06501825	41.4	49.3	56.8	50	60	6	6
20D	4HK06501025	23.1	33.8	38.1	35	40	8	8
	4HK06501525	34.7	43.5	52.6	45	60	8	6

1. O.C.P. = Over Current Protection device, must be HACR type Circuit Breaker or Time Delay fuse.

2. Heaters are 3 Phase.

TABLE 17: Electrical Data - 460-3-60

MA Models	Heater Models	MAX. STATIC & MIN. CFM		Total Heat1		KW Staging		
		Static	Taps	KW	MBH	W1 Only	W2 Only	W1 + W2
				480V	480V	480V	480V	480V
12BN41	4HK06501046	0.5"	Med	9.6	3.28	9.6	9.6	9.6
16CN41	4HK06501046	0.5"	Med	9.6	3.28	9.6	9.6	9.6
	4HK06501546	0.5"	Med	14.4	4.92	14.4	14.4	14.4
20DN41	4HK06501046	0.5"	Med	9.6	3.28	9.6	9.6	9.6
	4HK06501546	0.5"	Med	14.4	4.92	14.4	14.4	14.4
	4HK06502946	0.5"	Med	28.8	9.84	14.4	28.8	28.8

TABLE 18: Electrical Data - (For **Single Source** Power Supply) - Copper Wire 3 Ø - 460-3-60

MA Models	Heater Models	Field Wiring		
		Min. Circuit Ampacity	Max. O.C.P. ¹ Amps/Type	Wire Size - AWG 75°C
		480V	480V	480V
12BN41	4HK06501046	17.4	20	12
16CN41	4HK06501046	17.8	25	10
	4HK06501546	24.9	25	10
20DN41	4HK06501046	19.1	25	10
	4HK06501546	26.3	30	8
	4HK06502946	48.0	50	8

1. OCP = Over Current Protection device, must be HACR type Circuit Breaker or Time Delay fuse.

TABLE 19: Air Flow Data - 60 Hz Models (230 & 460 Volt)

Models MA	Models MC	Blower Motor Speed	230 / 460 Volt - 60 Hz									
			CFM ¹ @ External Static Pressure - IWC									
			0.1	0.2	0.3	0.4	0.5	0.6	0.7	0.8	0.9	1
08B	MC18B**H	High	1102	986	870	754	638	521	405	289	173	57
		Med.	831	737	644	551	457	364	271	178	84	N/A
		Low	615	537	458	379	300	221	142	63	N/A	N/A
	MC24B**H	High	1112	1001	890	780	669	558	447	336	225	114
		Med.	851	759	667	576	484	392	300	208	116	25
		Low	643	562	480	399	317	236	154	73	N/A	N/A
12B	MC30B**H	High	1511	1355	1199	1043	887	731	576	420	264	108
		Med.	1241	1107	973	839	705	572	438	304	170	36
		Low	1100	980	861	741	622	502	383	263	144	24
	MC36B**H	High	1464	1286	1108	929	751	573	394	216	38	N/A
		Med.	1195	1050	905	761	616	471	326	181	37	N/A
		Low	1073	944	815	687	558	429	300	172	43	N/A
16C	MC42C**H	High	1959	1874	1802	1708	1606	1486	1408	1264	953	810
		Med.	1631	1587	1542	1473	1395	1315	1218	967	821	533
		Low	1447	1431	1401	1363	1304	1241	1098	844	751	712
	MC48C**H	High	2018	1895	1772	1649	1525	1402	1279	1156	1033	910
		Med.	1684	1595	1506	1417	1328	1240	1151	1062	973	884
		Low	1561	1476	1392	1308	1223	1139	1055	970	896	801
14D	MC48D**H	High	1715	1671	1608	1547	1460	1338	1232	1003	727	508
		Med.	1471	1438	1367	1318	1263	1180	920	824	587	503
		Low	1379	1330	1276	1227	1157	1047	866	681	567	392
	MC60D**H	High	1763	1713	1649	1581	1511	1407	1276	995	852	N/A
		Med.	1487	1462	1412	1356	1280	1210	1087	795	726	N/A
		Low	1381	1353	1292	1225	1186	1057	863	780	669	N/A
	MC61D**H	High	1746	1699	1655	1579	1486	1399	1264	1093	796	581
		Med.	1486	1442	1393	1333	1270	1189	1081	776	628	450
		Low	1392	1336	1285	1226	1158	1061	882	740	680	445
20D	MC48D**H	High	2226	2190	2103	2035	1931	1845	1683	1541	1465	1328
		Med.	2115	2087	2017	1951	1851	1744	1542	1466	1406	1254
		Low	N/A	N/A	N/A	1716	1643	1554	1451	1379	1292	1151
	MC60D**H	High	2326	2235	2192	2107	2027	1906	1786	1538	1469	1368
		Med.	2150	2089	2036	2008	1944	1852	1692	1499	1416	1295
		Low	1737	1752	1745	1718	1676	1600	1447	1389	1311	1200
	MC61D**H	High	2357	2321	2254	2191	2139	1951	1859	1656	1556	1472
		Med.	2212	2144	2111	2069	1986	1862	1727	1566	1498	1369
		Low	1765	1783	1803	1779	1723	1646	1514	1442	1381	1245

1. Includes return air filter, coil, and 10kW electric heater.

All MA series air handler units are UL Listed up to 0.50" w.c. external static pressure, including air filter, wet coil, and largest KW size heater.

TABLE 20: Air Flow Data - 60 Hz Models (208 Volt)

Models MA	Models MC	Blower Motor Speed	208 Volt - 60 Hz									
			CFM ¹ @ External Static Pressure - IWC									
			0.1	0.2	0.3	0.4	0.5	0.6	0.7	0.8	0.9	1
08B	MC18B**H	High	1080	964	848	732	615	499	383	267	150	34
		Med.	712	628	544	461	377	293	210	126	42	N/A
		Low	529	452	376	299	223	146	70	N/A	N/A	N/A
	MC24B**H	High	1039	932	825	717	610	502	395	288	180	73
		Med.	743	659	575	491	407	323	239	156	72	N/A
		Low	532	460	387	315	242	169	97	24	N/A	N/A
12B	MC30B**H	High	1444	1271	1099	927	755	582	410	238	65	N/A
		Med.	1101	967	833	699	565	431	297	163	29	N/A
		Low	937	824	711	598	485	372	260	147	34	N/A
	MC36B**H	High	1434	1267	1099	932	764	597	430	262	95	N/A
		Med.	1083	955	827	699	571	443	315	187	59	N/A
		Low	933	818	703	588	473	359	244	129	14	N/A
16C	MC42C**H	High	1782	1712	1619	1524	1435	1323	1213	985	798	557
		Med.	1468	1415	1355	1298	1233	1144	1005	791	669	493
		Low	1310	1278	1239	1185	1125	1045	934	725	561	424
	MC48C**H	High	1983	1865	1747	1629	1511	1393	1275	1157	1039	921
		Med.	1529	1446	1363	1280	1197	1114	1031	948	865	782
		Low	1312	1249	1185	1122	1059	995	932	868	805	742
14D	MC48D**H	High	1549	1498	1448	1383	1325	1235	1125	936	658	548
		Med.	1275	1269	1225	1181	1115	997	811	684	548	392
		Low	1190	1162	1112	1074	975	817	737	625	493	358
	MC60D**H	High	1545	1490	1463	1378	1337	1231	1115	850	739	572
		Med.	1266	1248	1207	1140	1101	1005	839	687	564	469
		Low	1192	1186	1126	1067	992	842	740	638	507	347
	MC61D**H	High	1564	1520	1455	1400	1336	1257	1154	813	755	549
		Med.	1303	1262	1225	1165	1117	1028	827	744	590	398
		Low	1204	1161	1104	1060	1001	870	745	554	532	462
20D	MC48D**H	High	2250	2180	2139	2062	1971	1855	1683	1553	1461	1342
		Med.	1953	1956	1905	1858	1755	1649	1528	1440	1355	1245
		Low	N/A	N/A	1544	1538	1455	1401	1346	1285	1195	1081
	MC60D**H	High	2251	2186	2144	2073	2003	1921	1809	1574	1478	1370
		Med.	1987	1945	1926	1887	1836	1761	1643	1472	1387	1213
		Low	1492	1517	1521	1523	1507	1436	1379	1308	1213	1128
	MC61D**H	High	2208	2123	2092	2054	1910	1762	1595	1496	1435	1298
		Med.	1959	1945	1913	1862	1766	1661	1513	1420	1315	1182
		Low	N/A	N/A	N/A	1546	1491	1407	1354	1258	1184	1088

1. Includes return air filter, coil, and 10kW electric heater.

All MA series air handler units are UL Listed up to 0.50" w.c. external static pressure, including air filter, wet coil, and largest KW size heater.

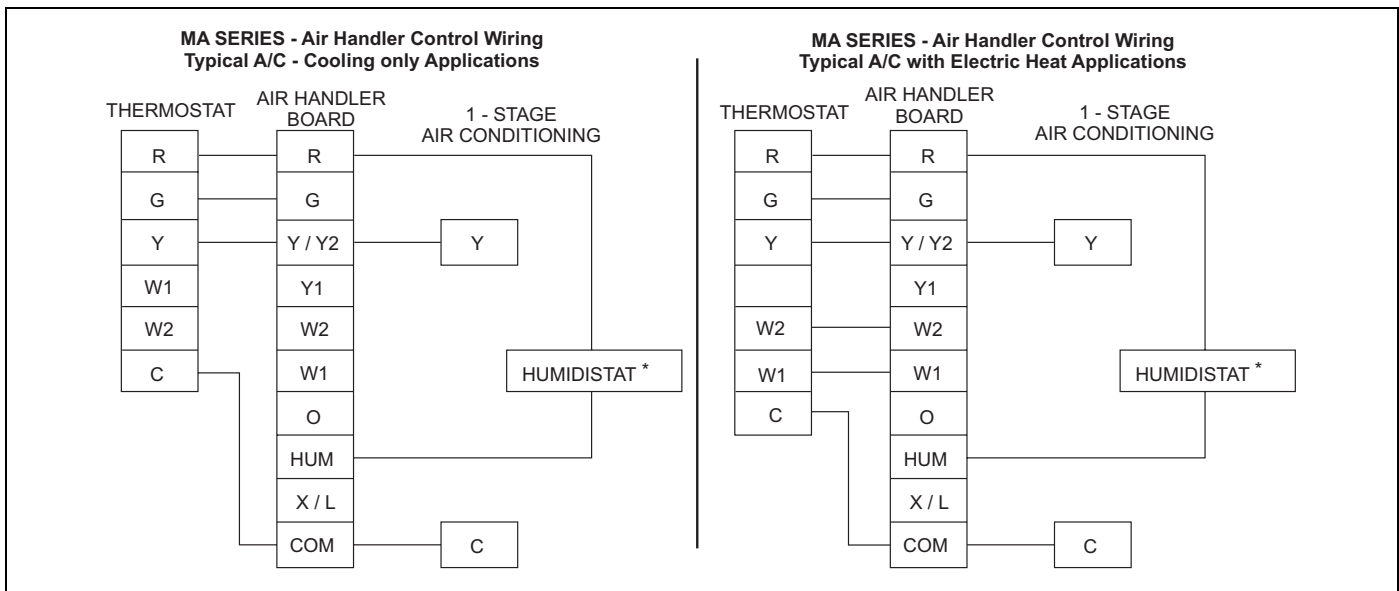

FIGURE 10: Cooling Models with Electric Heat Wiring

1. "Y" Terminal on Air Handler Control Board must be connected for full CFM and applications requiring 60 second blower off delay for SEER enhancement.
2. Optional humidity switch - contacts open on humidity rise.
3. Remove HUM STAT Jumper on AH Control Board
4. MODE Jumper on AH control board should be set to A/C for air conditioners and HP for heat pumps.
5. To change quantity of heat during HP defrost cycle - Reverse connections at W1 & W2 on Air Handler Control Board

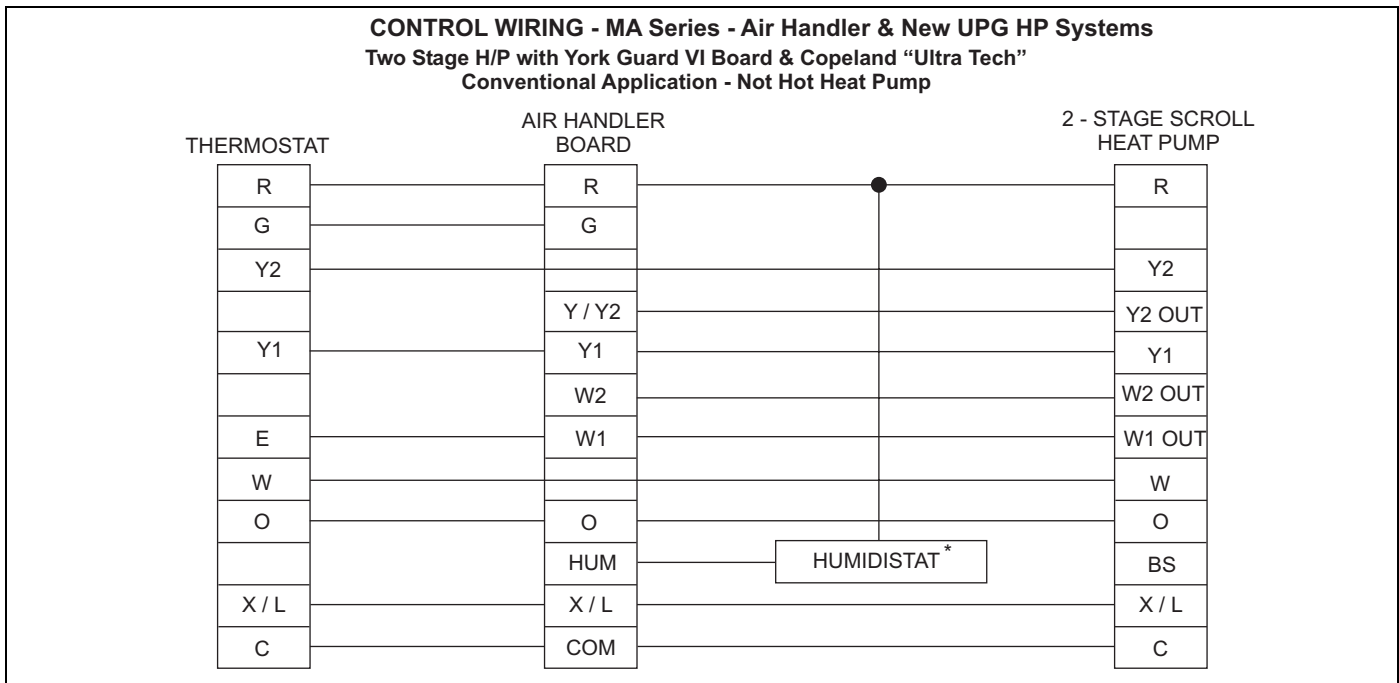

FIGURE 11: Two-Stage Cooling Wiring

1. "Y" Terminal on Air Handler Control Board must be connected for full CFM and applications requiring 60 second blower off delay for SEER enhancement.
2. Optional humidity switch - contacts open on humidity rise.
3. Remove HUM STAT Jumper on AH Control Board
4. MODE Jumper on AH control board should be set to A/C for air conditioners and HP for heat pumps.
5. To change quantity of heat during HP defrost cycle - Reverse connections at W1 & W2 on Air Handler Control Board

SECTION X: MAINTENANCE

Filters must be cleaned or replaced when they become dirty. Inspect at least once per month. The frequency of cleaning depends upon the hours of operation and the local atmospheric conditions. Clean filters keep unit efficiency high.

LUBRICATION

The bearings of the blower motor are permanently lubricated.