

SA1C-FK: Fiber Optic Analog Photoelectric Sensors

- High-speed, miniature photoelectric sensors with analog (4mA to 20mA) and digital output
- Senses gradual color changes
- Available in both red and green LEDs
- Through-beam and reflected-light sensing available
- Ideal for either color mark applications or simple presence and absence applications requiring analog output
- Compact size allows for DIN rail mounting
- Dozens of coordinating fiber optic units available to address specific application needs
- Simple to install and program
- IP66 protection rating



	SA1C-FK3	SA1C-FK3G
Light Source Element	Red LED	Green LED
Sensing Distance	Depends on the fiber unit (see pages 35–37)	
Power Voltage	12 to 24V DC (Operating voltage: 10 to 30V DC) ripple 10% maximum	
Current Draw	80mA maximum	
Analog Current Output	4 to 20mA, 5V DC maximum	
Digital Output	NPN open collector 30V DC, 100mA maximum, 1.5V maximum with short circuit protection	
Operation Mode	Dark ON (connect MODE line to GND line); Light ON (connect MODE line to power line)	
Response	0.5ms maximum	
Indicator	Operation LED: Red, Stable LED: Green	
Detectable Object	Translucent object, opaque object	
Hysteresis	20% maximum (using reflex fiber unit)	
Sensitivity	4-turn adjustment	
Operation Point Control	1 turn	
Receiver Element	Photo diode	
Operating Temperature	–25 to +55°C (performance will be adversely affected if the sensor becomes coated with ice)	
Storage Temperature	–30 to +70°C (performance will be adversely affected if the sensor becomes coated with ice)	
Operating Humidity	35 to 85% RH (avoid condensation)	
Extraneous Light Immunity	Sunlight: 10,000 lux maximum; Incandescent light: 3,000 lux (at the receiver)	
Noise Resistance	Normal mode: 500V (50ns to 1μs, 100Hz: Using a noise simulator) Common mode: 300V (50ns to 1μs, 100Hz: Using a noise simulator)	
Insulation Resistance	Between live and dead parts: 20MΩ minimum, with 500V DC megger	
Dielectric Strength	Between live and dead parts: 1,000V, 1 minute	
Vibration Resistance	Damage limits: 10 to 55Hz; Single amplitude: 0.75mm 20 cycles in each of 3 axes	
Shock Resistance	Damage limits: 500 m/sec ² 10 cycles in each of 3 axes	
Degree of Protection	IP66 — IEC Pub 529	
Cable	Cable type: Ø4.4mm 5-core vinyl cable 0.2mm ² , 6'-6-3/4" (2m) long	
Material	Housing: Polybutyleneterephthalate (PBT)	
Accessories	Mounting bracket, adjusting screwdriver, load resistor (249Ω) for converting analog amperage to voltage (1 to 5V)	
Interference Prevention	Up to 2 units can be installed in close proximity. For analog output, interference prevention is not possible.	
Weight	Approximately 75g	

General Specifications

Sensors



1. Analog current output specification is based on the power voltage range from 12 to 24V DC ($\pm 10\%$).
2. Use the attached resistor (249Ω, 1/4W) as a load resistance for converting analog output to voltage.
3. Response time for analog current output is between 10% and 90% of the rise or fall of the voltage signal when using a 249Ω resistor.

Part Numbers: SA1C-FK Sensors

Part Number	Light Source Element	Output
SA1C-FK3	Red LED	Analog output + NPN output (with short-circuit)
SA1C-FK3G	Green LED	

Ordering Details

The SA1C-FK series consists of the amplifier/receiver only. Fiber optic units must be ordered separately using part numbers beginning with SA9F. SA1C-FK amplifier/receivers can be used with either through-beam or diffuse-reflected fiber optic units.

The fiber optic cord is 6'-6-3/4" (2m) long. Fiber optic cords can be cut to the desired length using a fiber cutter, except for heat-resistant glass fiber cords. A fiber cutter is included with fiber optic units (order SA9Z-F01 separately for replacement). A set of two easy-insert adaptors is included with the following fiber optic units: SA9F-TT, SA9F-TL, SA9F-DT, and SA9F-DL (order SA9Z-F02 for replacement set).

Part Numbers: SA9F Diffuse-Reflected Light Fiber Optic Units

Part Number	Description	Amplifier	Range	Dimensions
SA9F-DS31 No sleeve SA9F-DS32 3.54" (90mm) sleeve SA9F-DS33 1.77" (45mm) sleeve	Straight: Two fibers Ø 0.04" (1mm) Threaded mount: Ø 0.24" (M6) Detects: Ø 0.0012" (0.03mm) minimum object	SA1C-FK3 SA1C-FK3G	2.36" (60mm) 0.28" (7mm)	
SA9F-DC31 No sleeve SA9F-DC32 3.54" (90mm) sleeve SA9F-DC33 1.77" (45mm) sleeve (All three not compatible with green LED)	Coiled: Two fibers Ø 0.04" (1mm) Threaded mount: Ø 0.24" (M6) Detects: Ø 0.0012" (0.03mm) minimum object	SA1C-FK3 SA1C-FK3G	0.98" (25mm) —	
SA9F-DT11 No sleeve SA9F-DT12 3.54" (90mm) sleeve SA9F-DT13 1.77" (45mm) sleeve (All three not compatible with green LED)	Straight: Two fibers Ø 0.02" (0.5mm) Threaded mount: Ø 0.12" (M3) Detects: Ø 0.0012" (0.03mm) minimum object	SA1C-FK3 SA1C-FK3G	0.78" (20mm) —	
SA9F-DD31	Coaxial: Core Ø 0.04" (1mm) + 16 fibers: Ø 0.01" (0.26mm) Threaded mount: Ø 0.24" (M6) Detects: Ø 0.0012" (0.03mm) minimum object	SA1C-FK3 SA1C-FK3G	2.36" (60mm) 0.28" (7mm)	

(continued on following page)

Part Numbers: SA9F Diffuse-Reflected Light Fiber Optic Units, continued

Part Number	Description	Amplifier	Range	Dimensions
<p>SA9F-DM74 1 row = 32 fibers SA9F-DM75 2 rows = 16 each (Not compatible with green LED) SA9F-DM76 3 rows = 16 center + 8 fibers each side (Not compatible with green LED)</p>	<p>Multicore: 32 fibers Ø 0.010" (0.26mm) Detects: Ø 0.0024" (0.06mm) minimum object</p>	<p>SA1C-FK SA1C-FK3G (not compatible with SA9F-DM75, SA9F-DM76)</p>	<p>2.36" (60mm) 0.16" (4mm)</p>	
<p>SA9F-DH21 No sleeve SA9F-DH22 3.54" (90mm) sleeve (Both not compatible with green LED)</p>	<p>Heat-resistant glass: Two fibers Ø 0.03" (0.7mm) Threaded mount: Ø 0.16" (M4) Detects: Ø 0.0012" (0.03mm) minimum object</p>	<p>SA1C-FK3 SA1C-FK3G</p>	<p>1.06" (27mm) —</p>	

Measuring Conditions

Amplifier = Applicable Amplifier

Range = Sensing Range
Sensing a 50 x 50mm piece of white paper

Minimum detectable object:
Sensing a copper-stranded wire with the SA1C-FK3

The sensing range varies depending upon the sensing conditions.

Part Numbers: SA9F Through-Beam Fiber Optic Units

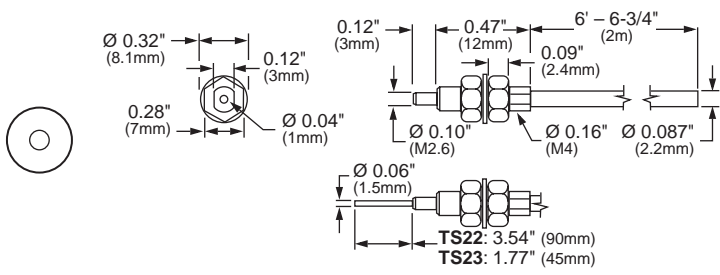
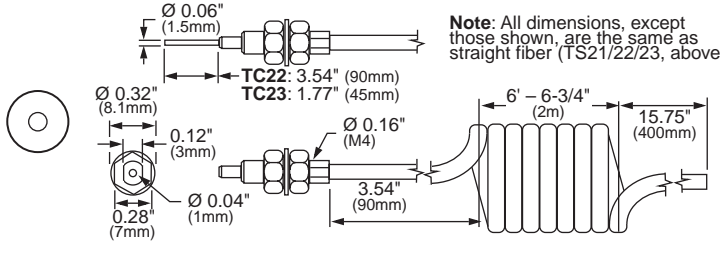
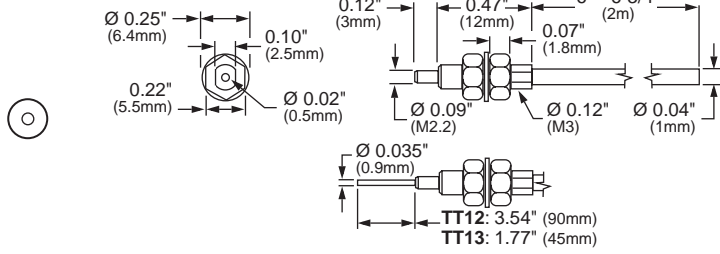
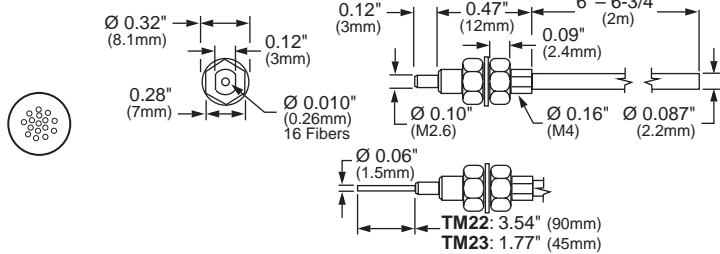
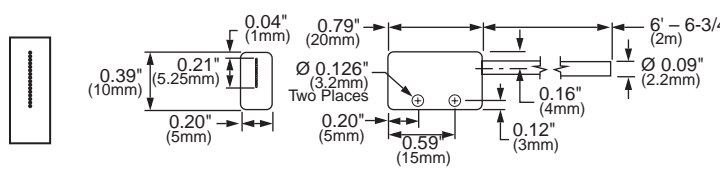
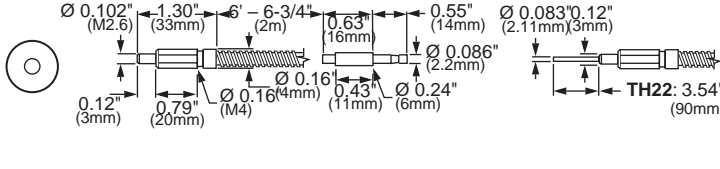
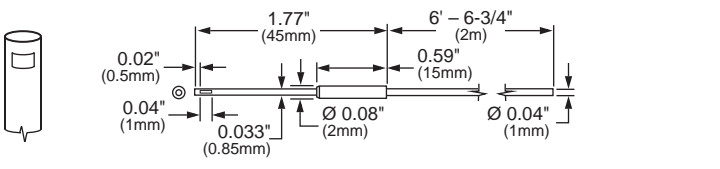
Part Number	Description	Amplifier	Range	Dimensions
SA9F-TS21 No sleeve SA9F-TS22 3.54" (90mm) sleeve SA9F-TS23 1.77" (45mm) sleeve	Straight fiber: Ø 0.04" (1mm) Threaded mount: Ø 0.16" (M4) Detects: Ø 0.012" (0.3mm) minimum object	SA1C-FK3 SA1C-FK3G	7.09" (180mm) 0.63" (16mm)	
SA9F-TC21 No sleeve SA9F-TC22 3.54" (90mm) sleeve SA9F-TC23 1.77" (45mm) sleeve	Coiled fiber: Ø 0.04" (1mm) Threaded mount: Ø 0.16" (M4) Detects: Ø 0.012" (0.3mm) minimum object	SA1C-FK3 SA1C-FK3G	5.91" (150mm) 0.55" (14mm)	
SA9F-TT11 No sleeve SA9F-TT12 3.54" (90mm) sleeve SA9F-TT13 1.77" (45mm) sleeve	Straight fiber: Ø 0.02" (0.5mm) Threaded mount: Ø 0.12" (M3) Detects: Ø 0.006" (0.15mm) minimum object	SA1C-FK3 SA1C-FK3G	1.97" (50mm) 0.2" (5mm)	
SA9F-TM21 No sleeve SA9F-TM22 3.54" (90mm) sleeve SA9F-TM23 1.77" (45mm) sleeve	Multicore: 16 fibers (cluster) Ø 0.010" (0.26mm) Threaded mount: Ø 0.16" (M4) Detects: Ø 0.012" (0.3mm) minimum object	SA1C-FK3 SA1C-FK3G	5.91" (150mm) 0.55" (14mm)	
SA9F-TM74 16 fibers in one row	Multicore: 16 fibers (one row) Ø 0.010" (0.26mm) Detects: Ø 0.0024" (0.06mm) minimum object	SA1C-FK3 SA1C-FK3G	5.91" (150mm) 0.55" (14mm)	
SA9F-TH21 No sleeve SA9F-TH22 3.54" (90mm) sleeve	Heat-resistant glass fiber: Ø 0.04" (1mm) Threaded mount: Ø 0.16" (M4) Detects: Ø 0.012" (0.3mm) minimum object	SA1C-FK3 SA1C-FK3G	3.94" (100mm) 0.31" (8mm)	
SA9F-TL53 (Not compatible with green LED)	Side view: one fiber 0.02" (0.5mm) Optical axis at 90° Detects: Ø 0.0024" (0.06mm) minimum object	SA1C-FK3 SA1C-FK3G	1.57" (40mm)	



Refer to page Q-36 for the measuring conditions.

Applications

Monitoring the gradual change in liquid densities

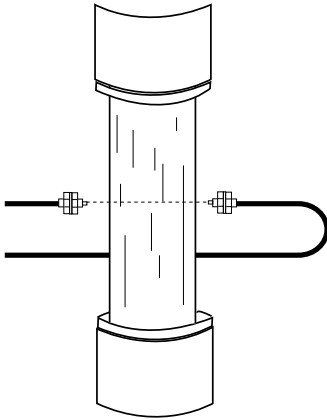

Detecting the roundness of rollers

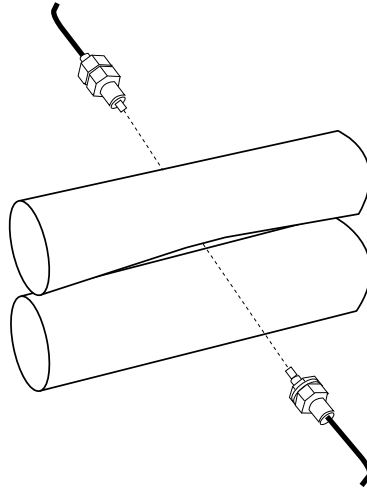

Sensing position or alignment

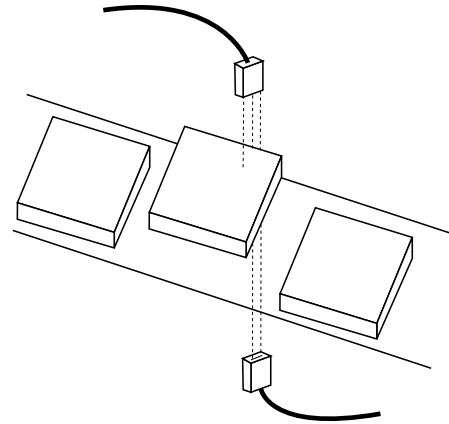

Checking size

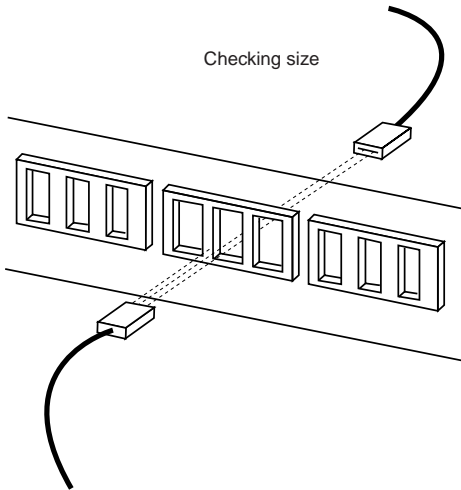

Checking height

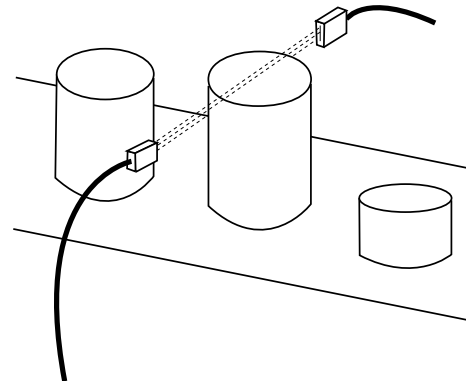

Controlling web tension

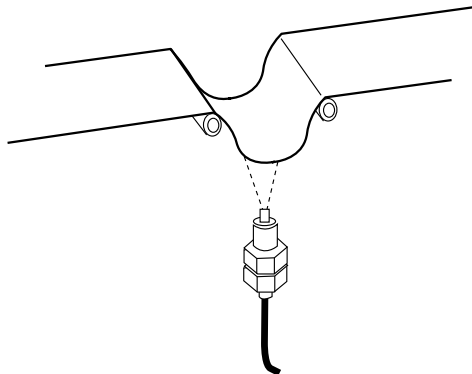

Sensing color marks

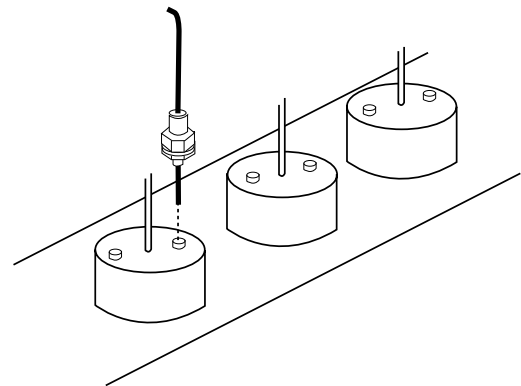

Dimensions

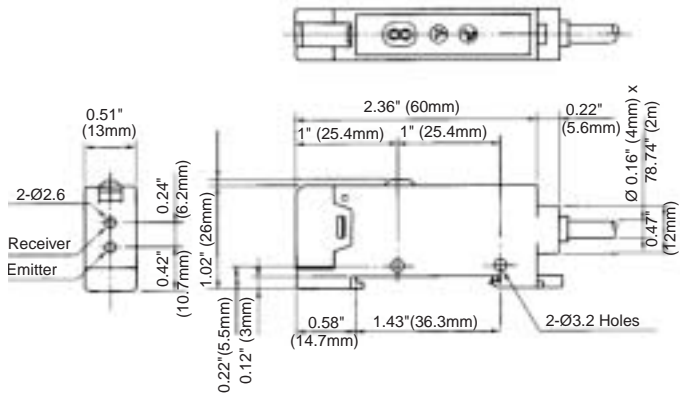

Mounting Bracket (attachment)
Not Required for DIN Rail Mounting

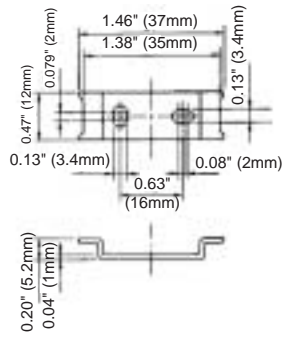

Mounting Hole Layout

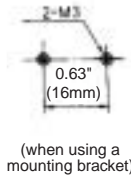

SA1C-F: High-Speed, Miniature Photoelectric Sensors with Fiber Optics

- Ideal for remote sensing applications
- Featuring quick-connect cable and easy-insert fiber optic units for simple installation
- Through-beam and reflected-light sensing available
- Sensing range up to 7.09" (180mm) for through-beam sensors
- Dual outputs: Select NPN and PNP transistor outputs or NPN transistor output combined with a self-diagnostic output
- Outputs selectable for light on or dark on
- High-speed, 50µs response time
- Featuring variable off-delay (0 to 100 ms) and fine-tune sensitivity adjustment
- Stable LED makes alignment easy
- Red or green LEDs available for detecting color marks
- Mount on a 1.378" (35mm) DIN rail
- Protection rated IP66

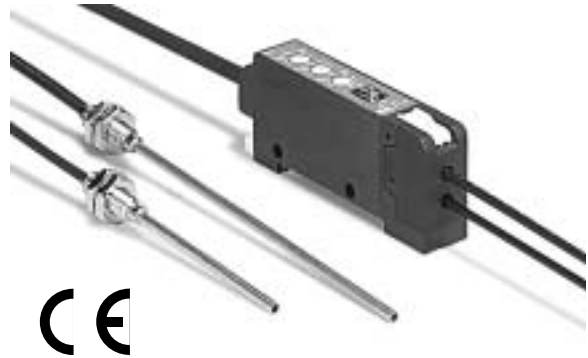

General Specifications	Power Voltage	12V to 24V DC
	Operating Voltage	10V to 30V DC, ripple 10% (maximum)
	Current Draw	Standard speed: 30mA (maximum) High-speed: 40mA (maximum)
	Operating Temperature	Amplifier only: -25° to +55°C Fiber optic cords (except heat-resistant types): -40° to +70°C Heat-resistant fiber optic cords: -40°C to +350°C (avoid ice coating)
	Operating Humidity	35 to 85% RH (avoid condensation)
	Extraneous Light Immunity	Sunlight: 10,000 lux (maximum); Incandescent light: 3,000 lux (maximum) on receiver surface— defined as incident or unwanted light received by a sensor, unrelated to the presence or absence of the intended object
	Material	Amplifier only: PBT resin (housing) with polycarbonate lens Fiber optic cords (except heat-resistant types): Nickel-plated brass (sensing head), polyethylene-covered PMMA (cord), and SUS304 stainless (sleeve) Heat-resistant fiber optic cords: SUS 304 stainless (sensing head) and SUS spiral tube around glass fiber cord
	Degree of Protection	IP66 — IEC Pub 529, sensors rated IP66 are dust-tight, water-resistant, and perform best when not subjected to heavy particle or water blasts
	Cable	Cable type: 0.2mm ² , Vinyl cabtyre cable #24 AWG, 6'-6-3/4' (2m) long Connector type: Ø 0.31" (8mm) 3- or 4-pin connector (cable ordered separately for quick connect sensors)
	Light Source	Red or green LED (pulse-modulated)
	Output	NPN transistor: 30V DC (1.2V residual), 100mA (maximum) PNP transistor: 30V DC (2.0V residual), 200mA (maximum) Self-diagnostic: 30V DC (1.2V residual), 50mA (maximum)
	Response	Standard-speed: 0.5ms (maximum) High-speed: 50µs (maximum)
	Off Delay	0 to 100 ms (adjustable)
	Sensitivity	4-turn adjustment
Minimum Bending Radius	Fiber optic cord (except SA9F-TT, -DT, -TL, and -DL): 1"R (25mm); Sleeve: 0.39"R (10mm) SA9F-TT and -DT: 0.59"R (15mm); Sleeve: 0.39"R (10mm) SA9F-TL and DL: 0.59"R (15mm); Sleeve: Unbendable	

	SA1C-FN, -FD (standard speed)	SA1C-F1N, -F1D (high-speed)
Operation Mode	Light on or dark on (selectable by switch on amplifier)	
Indicator	Operation indicator: Red LED (out) Stable level indicator: Green LED (stable)	
Noise Resistance	Normal mode: 500V Common mode: 300V Pulse width: 50ns –1µs, 100Hz (using a noise simulator)	Normal mode: 300V Common mode: 150V Pulse width: 50ns –1µs, 100Hz (using a noise simulator)
Storage Temperature	-30 to +70°C (avoid freezing)	
Insulation Resistance	20M minimum with 500V DC megger (between live and dead parts)	
Dielectric Strength	1000V, 1 minute (between live and dead parts)	
Vibration Resistance	Damage limits: 10 – 55Hz Amplitude: 1.5mm p-p, 20 cycles in each of 3 axes crossed (one cycle = 5 minutes)	
Shock Resistance	Damage limits: 500m/S ² (approximately 49G), 10 shocks in each of 3 axes	
Weight	Cable type: Approximately 75g Quick-connect type: Approximately 30g	

Part Numbers: SA1C-F Fiber Optic Sensors

Amplifier Part Number	Output	Light Source	Response	Through-Beam Units Part Number	Range	Diffuse-Reflected Units Part Number	Range
SA1C-FN3E (Cable) SA1C-FN3EC (Quick-Connect)	30V DC NPN transistor: 100mA (maximum) Self-diagnostic: 50mA (maximum)	Red LED	Standard speed: 0.5 ms	SA9F-TS: Ø 0.16" (M4) Straight SA9F-TC: Ø 0.16" (M4) Coiled SA9F-TT: Ø 0.12" (M3) Straight SA9F-TM: Ø 0.16" (M4) Multicore SA9F-TH: Heat-resistant glass fiber SA9F-TL: Side view	7.09" (180mm)	SA9F-DS: Ø 0.24" (M6) Straight SA9F-DC: Ø 0.24" (M6) Coiled SA9F-DD: Ø 0.24" (M6) Coaxial SA9F-DT: Ø 0.12" (M3) Straight SA9F-DM: Ø 0.01" (0.26mm) Multicore SA9F-DH: Heat-resistant glass fiber SA9F-DL: Side view	2.36" (60mm)
SA1C-FD3F (Cable) SA1C-FD3FC (Quick-Connect)	30V DC NPN transistor: 100mA (maximum) PNP transistor: 200mA (maximum)				5.91" (150mm)		0.98" (25mm)
SA1C-FN3EG (Cable) SA1C-FN3EGC (Quick-Connect)	30V DC NPN transistor: 100mA (maximum) Self-diagnostic: 50mA (maximum)	Green LED	Standard speed: 0.5 ms	SA9F-TS: Ø 0.16" (M4) Straight SA9F-TC: Ø 0.16" (M4) Coiled SA9F-TT: Ø 0.12" (M3) Straight SA9F-TM: Ø 0.16" (M4) Multicore SA9F-TH: Heat-resistant glass fiber SA9F-TL: Incompatible with green LED	0.63" (16mm)	SA9F-DS: Ø 0.24" (M6) Straight SA9F-DC: Incompatible with green LED SA9F-DD: Ø 0.24" (M6) Coaxial SA9F-DT: Incompatible with green LED SA9F-DM: Ø 0.01" (0.26mm) Multicore SA9F-DH: Incompatible with green LED SA9F-DL: Incompatible with green LED	0.28" (7mm)
SA1C-FD3FG (Cable) SA1C-FD3FGC (Quick-Connect)	30V DC NPN transistor: 100mA (maximum) PNP transistor: 200mA (maximum)				0.55" (14mm)		N/A
SA1C-F1N3E (Cable) SA1C-F1N3EC (Quick-Connect)	30V DC NPN transistor: 100mA (maximum) Self-diagnostic: 50mA (maximum)	Red LED	High- speed: 50 µs	SA9F-TS: Ø 0.16" (M4) Straight SA9F-TC: Ø 0.16" (M4) Coiled SA9F-TT: Ø 0.12" (M3) Straight SA9F-TM: Ø 0.16" (M4) Multicore SA9F-TH: Heat-resistant glass fiber SA9F-TL: Side view	1.97" (50mm)	SA9F-DS: Ø 0.24" (M6) Straight SA9F-DC: Ø 0.24" (M6) Coiled SA9F-DD: Ø 0.24" (M6) Coaxial SA9F-DT: Ø 0.12" (M3) Straight SA9F-DM: Ø 0.01" (0.26mm) Multicore SA9F-DH: Heat-resistant glass fiber SA9F-DL: Side view	0.79" (20mm)
SA1C-F1D3F (Cable) SA1C-F1D3FC (Quick-Connect)	30V DC NPN transistor: 100mA (maximum) PNP transistor: 200mA (maximum)				1.57" (40mm)		0.28" (7mm)
					0.59" (15mm)		0.79" (20mm)
					1.57" (40mm)		0.24" (6mm)
					1.18" (30mm)		0.71" (18mm)
					0.51" (13mm)		0.28" (7mm)
							0.12" (3mm)











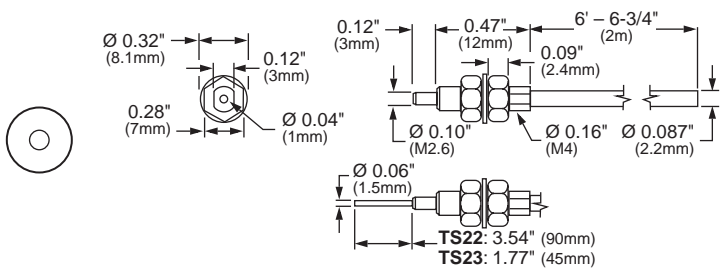

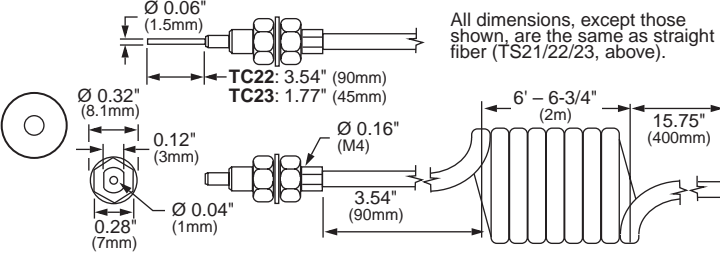

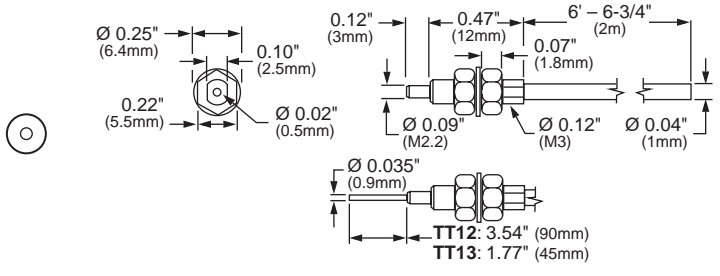
Ordering Details

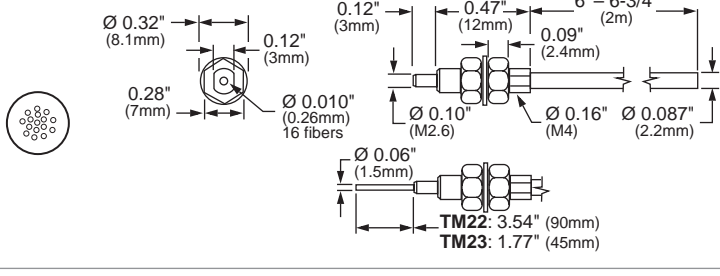
The SA1C-F series consists of the amplifier/receiver only. Fiber optic units must be ordered separately using part numbers beginning with SA9F. SA1C-F amplifier/receivers can be used with either the through-beam or diffuse-reflected fiber optic units.

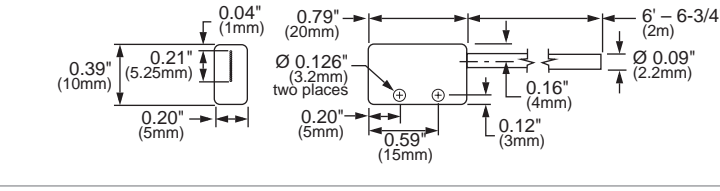
Amplifier/receiver units include a mounting bracket, screws, and a screwdriver. Cables for quick-connect sensors are ordered separately. Optional attachments, available for modifying beam size of through-beam sensors, are also ordered separately (see pages Q-44 through Q-45).

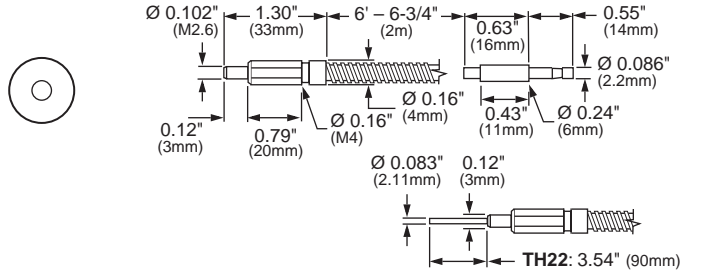
The fiber optic cord is 6' – 6-3/4" (2m) long. The fiber optic cord can be cut to desired length using a fiber cutter, except for the heat-resistant glass fiber. A fiber cutter is included with fiber optic units (order SA9Z-F01 separately for replacement). A set of two easy-insert adaptors is included with the following fiber optic units: SA9F-TT, SA9F-TL, SA9F-DT, and SA9F-DL (order SA9Z-F02 for replacement set).

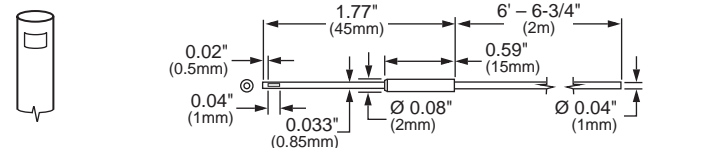
Part Numbers: SA9F Through-Beam Fiber Optic Units

Part Number	Description	Dimensions	Appearance
SA9F-TS21 No sleeve SA9F-TS22 3.54" (90mm) sleeve SA9F-TS23 1.77" (45mm) sleeve	Straight fiber: Ø 0.04" (1mm) Threaded mount: Ø 0.16" (M4) Detects: Ø 0.012" (0.3mm) minimum object		
SA9F-TC21 No sleeve SA9F-TC22 3.54" (90mm) sleeve SA9F-TC23 1.77" (45mm) sleeve	Coiled fiber: Ø 0.04" (1mm) Threaded mount: Ø 0.16" (M4) Detects: Ø 0.012" (0.3mm) minimum object		
SA9F-TT11 No sleeve SA9F-TT12 3.54" (90mm) sleeve SA9F-TT13 1.77" (45mm) sleeve	Straight fiber: Ø 0.02" (0.5mm) Threaded mount: Ø 0.12" (M3) Detects: Ø 0.006" (0.15mm) minimum object		
SA9F-TM21 No sleeve SA9F-TM22 3.54" (90mm) sleeve SA9F-TM23 1.77" (45mm) sleeve	Multicore: 16 fibers (cluster) Ø 0.010" (0.26mm) Threaded mount: Ø 0.16" (M4) Detects: Ø 0.012" (0.3mm) minimum object		
SA9F-TM74 16 fibers in one row	Multicore: 16 fibers (one row) Ø 0.010" (0.26mm) Detects: Ø 0.0024" (0.06mm) minimum object		
SA9F-TH2 No sleeve SA9F-TH22 3.54" (90mm) sleeve	Heat-resistant glass fiber: Ø 0.04" (1mm) Threaded mount: Ø 0.16" (M4) Detects: Ø 0.012" (0.3mm) minimum object		
SA9F-TL53 (not compatible with green LED)	Side view: One fiber 0.02" (0.5mm) Optical axis at 90° Detects: Ø 0.0024" (0.06mm) minimum object		

Sensors

Part Numbers: SA9F Diffuse-Reflected Light Fiber Optic Units

Part Number	DESCRIPTION	Dimensions	Appearance
SA9F-DS31 No sleeve SA9F-DS32 3.54" (90mm) sleeve SA9F-DS33 1.77" (45mm) sleeve	Straight: Two fibers Ø 0.04" (1mm) Threaded mount: Ø 0.24" (M6) Detects: Ø 0.0012" (0.03mm) minimum object		
SA9F-DC31 No sleeve SA9F-DC32 3.54" (90mm) sleeve SA9F-DC33 1.77" (45mm) sleeve (all three not compatible with green LED)	Coiled: Two fibers Ø 0.04" (1mm) Threaded mount: Ø 0.24" (M6) Detects: Ø 0.0012" (0.03mm) minimum object	<p>All dimensions, except those shown, are the same as straight fiber (DS31/32/33, above).</p>	
SA9F-DT11 No sleeve SA9F-DT12 3.54" (90mm) sleeve SA9F-DT13 1.77" (45mm) sleeve (all three not compatible with green LED)	Straight: Two fibers Ø 0.02" (0.5mm) Threaded mount: Ø 0.12" (M3) Detects: Ø 0.0012" (0.03mm) minimum object		
SA9F-DD31	Coaxial: Core Ø 0.04" (1mm) + 16 fibers: Ø 0.01" (0.26mm) Threaded mount: Ø 0.24" (M6) Detects: Ø 0.0012" (0.03mm) minimum object		
SA9F-DM74 1 row = 32 fibers SA9F-DM75 2 rows = 16 each (Not compatible with green LED) SA9F-DM76 3 rows = 16 center + 8 fibers each side (not compatible with green LED)	Multicore: 32 fibers Ø 0.010" (0.26mm) Detects: Ø 0.0024" (0.06mm) minimum object	<p>One Row (DM74)</p> <p>Two and Three Rows (DM75/76)</p>	

(continued on following page)

Part Numbers: SA9F Diffuse-Reflected Light Fiber Optic Units, continued

Part Number	Description	Dimensions	Appearance
<p>SA9F-DH21 No sleeve</p> <p>SA9F-DH22 3.54" (90mm) sleeve (both not compatible with green LED)</p>	<p>Heat-resistant glass: Two fibers Ø 0.03" (0.7mm)</p> <p>Threaded mount: Ø 0.16" (M4)</p> <p>Detects: Ø 0.0012" (0.03mm) minimum object</p>		
<p>SA9F-DL63 (not compatible with green LED)</p>	<p>Side view: Two fibers Ø 0.02" (0.5mm) Optical axis at 90°</p> <p>Detects: Ø 0.0012" (0.03mm) minimum object</p>		

Part Numbers: Accessories

Part Number	Description	Used With	Dimensions
<p>SA9C-CA4D2 4-core cable with connector 6'-6-3/4" (2m)</p>	<p>4-core cable with connector 16'-4-7/8" (5m)</p>	<p>SA1C-F quick-connect only, NPN and PNP outputs</p>	
<p>SA9C-CA4D5</p>			
<p>SA9C-CA4D2S 4-core cable with connector 6'-6-3/4" (2m)</p>	<p>4-core cable with connector 16'-4-7/8" (5m)</p>	<p>SA1C-F quick-connect only, NPN and self-diagnostic outputs</p>	
<p>SA9C-CA4D5S</p>			
<p>SA9Z-F01</p>	<p>Fiber cutter</p>	<p>All fiber units except heat resistant</p>	<p>HxLxD: 0.91" x 1.77" x 0.31" (23x 45 x 8Dmm) Included with fiber units; order replacement only</p>
<p>SA9Z-F02</p>	<p>Set of 2 easy-insert adaptors</p>	<p>SA9F-TT, SA9F-TL, SA9F-DT, and SA9F-DL</p>	<p>Ø 0.087" (OD) x 0.945" long (Ø 2.2mm x 24mm) Included with applicable fiber optic units; order replacement set only</p>

(continued on following page)

Part Numbers: Accessories, continued

Part Number	Description	Used With	Dimensions
SA9Z-F11	Lens attachment for long-range detection of opaque objects, minimum size: Ø 0.14" (3.5mm)	SA1C-F through-beam fiber unit only Sensing ranges: Standard speed red LED: SA9F-TS21: 4' - 3-3/16" (1.3m) 5.31" (0.135m) SA9F-TC21: 3' - 3-3/8" (1m) 3.94" (0.1m) SA9F-TM21: 3' - 5-3/8" (1.05m) 5.12" (0.13m) Sensing ranges: Standard speed green LED: SA9F-TS21: 5.31" (0.135m) SA9F-TC21: 3.94" (0.1m) SA9F-TM21: 5.12" (0.13m) Sensing ranges: High-speed red LED: SA9F-TS21: 5.75" (0.4m) SA9F-TC21: 1.81" (0.3m) SA9F-TM21: 4.96" (0.38m)	
SA9Z-F12	Side view attachment to rotate axis by 90° for detection of opaque objects, minimum size: Ø 0.14" (3.5mm)	SA1C-F through-beam fiber unit only Sensing ranges: Standard speed red LED: SA9F-TS21: 7.87" (200mm) SA9F-TC21: 5.12" (130mm) SA9F-TM21: 6.30" (160mm) Sensing ranges: High-speed red LED: SA9F-TS21: 1.97" (50mm) SA9F-TC21: 1.38" (35mm) SA9F-TM21: 1.57" (40mm)	
SA9Z-F13	Side-on attachment for narrow clearance, Range: 1.26" (32mm), for detection of transparent or opaque objects	SA1C-F diffuse-reflected light fiber unit only Sensing ranges: Standard speed red LED: SA9F-TS21: 1.38" (35mm) SA9F-TC21: 1.81" (30mm) SA9F-TM21: 1.38" (35mm)	
SA9Z-F14	Attachment for high-accuracy: Range: 0.4" ± 0.04" (10mm ± 1mm), for detection of transparent or opaque objects	SA1C-F through-beam fiber unit only Sensing ranges: Standard speed red LED: SA9F-TS21: 0.394" ± 0.039" SA9F-TC21: 10mm ± 1mm SA9F-TM21: 10mm ± 1mm	

Detecting Color Marks

Color of Mark	Background Color										
	White	Yellow	Chartreuse	Orange	Red	Magenta	Turquoise	Blue	Violet	Green	Black
□ = Use Red LED											
☆ = Use Green LED											
◆ = Use Red or Green LED											
— = Not Detectable											
White	—	☆	◆	☆	☆	◆	◆	◆	◆	◆	◆
Yellow	☆	—	◆	☆	☆	☆	◆	◆	◆	◆	◆
Chartreuse	◆	◆	—	□	□	☆	□	◆	☆	◆	◆
Orange	☆	☆	□	—	—	☆	□	◆	◆	◆	◆
Red	☆	☆	□	—	—	□	□	◆	◆	◆	◆
Magenta	◆	☆	☆	☆	□	—	□	□	—	□	◆
Turquoise	◆	◆	□	□	□	□	—	□	◆	☆	◆
Blue	◆	◆	◆	◆	◆	□	□	—	□	□	□
Violet	◆	◆	☆	◆	◆	—	◆	□	—	□	□
Green	◆	◆	◆	◆	◆	□	☆	□	□	—	□
Black	◆	◆	◆	◆	◆	◆	◆	□	□	□	—

Dimensions

SA1C-F Series Amplifier Unit

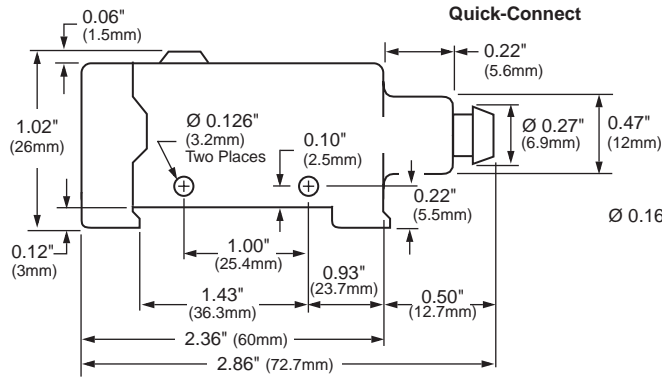
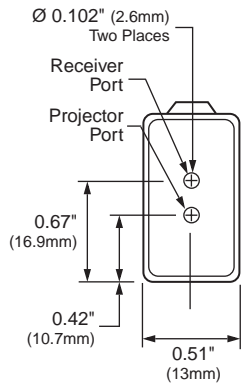
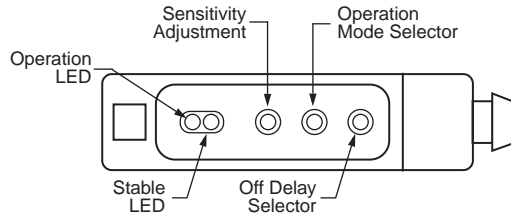

Cable Style

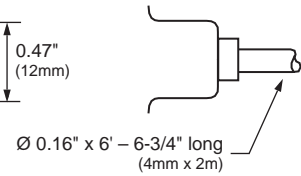

For dimensions on fiber optic units, see page Q-42 (through-beam) or pages Q-43 through Q-44 (diffuse-reflected light).

General Information

Specifications

Do not operate a sensor under any conditions exceeding these specifications.

Do not operate a sensor under current and voltage conditions other than those for which the individual sensor is rated.

Do not exceed the recommended operating temperature and humidity. Although sensors are rated for operation below 0°C, this specification does not imply that performance characteristics will remain constant under prolonged freezing conditions. Continued exposure and the accompanying frost, ice, dew, and condensation which accumulate on the optical surface will adversely affect sensor performance.

To maintain superior performance characteristics, do not exceed vibration and shock resistance ratings while operating a sensor. In addition, avoid isolated impacts to the sensor housing which are severe enough to adversely affect the waterproof characteristics.

IEC (International Electrotechnical Commission) Ratings

Sensors rated IP67 are resistant to moisture when occasionally immersed in still water. Sensors rated IP64 through IP66 are resistant to moisture when occasionally subjected to splashing or when located in the vicinity of turbulent waters. These ratings do not imply that a sensor is intended for use under continual high-pressure water spray. Avoid such applications to maintain optimal sensor performance.

Sensors rated IP64 through IP67 are dust-tight and water-tight. For best performance, avoid using any sensor in an area where it will be subjected to heavy particle blasts and where dust, water, or steam will accumulate on the optical surface.

Start-up

Do not test the housing for dielectric strength and insulation resistance, since the housing is connected to the electronic circuit ground of a sensor. Do not perform dielectric strength and insulation resistance tests on electrical systems without disconnecting photoelectric sensors, as such testing may result in damage to the sensor.

Several lines of sensors, as noted in the individual *operation* sections, are provided with an internal circuit to turn an output off for a specified amount of time upon power-up. This delay is normal; it prevents a transient state when turning power on.

Optimum Performance

The optical surface of each sensor must be cleaned on a regular basis for continual superior performance. Use a soft cloth dipped in isopropyl alcohol to remove dust and moisture build-up.

IMPORTANT: Do not use organic solvents (such as thinner, ammonia, caustic soda, or benzene) to clean any part of a sensor.

All sensors experience signal inconsistencies under the influence of inductive noise. Do not use sensors in close proximity to transformers, large inductive motors, or generators. Avoid using sensors in direct contact with sources of excessive heat. Also avoid operation in close proximity to welding equipment.



1. Even though the SA6A ultrasonic sensor features protection against noise, there may be adverse effects from strong noise.
2. It is strongly recommended to avoid using any sensor where it will be continually subjected to elements which impair performance or cause corrosive damage to the sensor. In particular, avoid strong vibrations and shocks, corrosive gases, oils, and chemicals, as well as blasts of water, steam, dust, or other particles.

Extraneous Light

Bright, extraneous light such as sunlight, incandescent lights, or fluorescent lights may impair the performance of sensors in detecting color or light.



3. SA6A ultrasonic sensors are not affected by extraneous light.

Make sure that extraneous light does not exceed recommended levels found in the individual *specifications* sections. When 500 lux is specified, this is equal to 50 footcandles. The average factory illumination is ordinarily below this level, except in areas where visual inspection is being performed. Only in such brightly lit areas is incident light of particular concern.

Unwanted light interference can often be avoided simply by making sure that the optical receiver is not aimed directly toward a strong light source. When mounting direction cannot be adjusted, place a light barrier between all nearby light sources and the receiver.

Reflected-Light Sensors

When installing sensors which detect reflected light, make sure that unwanted light reflections from nearby surfaces, such as the floor, walls, reflective machinery, or stainless steel, do not reach the optical receiver.

Also, make sure that reflected-light sensors mounted in close proximity do not cause interfering reflections. When it is not possible to maintain the recommended clearance between sensors, as noted in the individual *installation* sections, provide light barriers between sensors.

Through-Beam Sensors

A slit attachment is available to modify the beam size of through-beam sensors. This option is recommended for detecting very small objects (near the size of the smallest object which a sensor can detect) or for eliminating light interference when sensors are mounted in close proximity.

Laser Sensors

IMPORTANT: Always consider safety when installing a laser sensor of any kind. Make sure that the laser beam cannot inadvertently shine into the eyes of people passing by or working in the vicinity. See safety information on page Q-20.

Mounting

The mounting bracket and hardware are included with sensors, where applicable. Use the appropriate hardware for mounting, along with washers and spring washers or lock nuts. Do not overtighten attachment hardware. Overtightening causes damage to the housing and will adversely affect the waterproof characteristics of the sensor.

Best results can be obtained when the sensor is mounted so that the object sensed is in the center of the beam, rather than when the object is located near the edges of the sensing window. In addition, the most reliable sensing occurs when the majority of the objects being sensed are well within the sensing range, rather than at the extreme near and far limits.

Wiring

Avoid running high-voltages or power lines in the same conduit with sensor signal lines. This prevents inaccurate results or damage from induced noise. Use a separate conduit when the influence of power lines or electromagnetic equipment may occur, particularly when the distance of the wiring is extended.

IMPORTANT: Connect the sensor cables and wires as noted in the individual *Wiring* sections. Failure to connect as shown in wiring diagrams will result in damage to the internal circuit.

When extending sensor cables and wires, make sure to use cables equal or superior to that recommended in the individual *specifications* sections.

When wiring terminals, be sure to prevent contact between adjoining terminals. When using ring or fork lug terminals, use the insulated sleeve style only. Each sensor terminal can accept only one ring of fork lug terminal.

On ISF series photoelectric sensors, use recommended cable, along with the attached packing gland and washer, when wiring the terminals. This ensures waterproof and dustproof characteristics.

Power Supply

Noise resistance characteristics are improved when a sensor is grounded to the 0V power terminal. If the 0V power terminal is not at ground potential, use a ceramic 0.01µF capacitor which can withstand 250V AC minimum.

When using a switching power supply, be sure to ground the FG terminal to eliminate high-frequency noise. The power supply should include an insulating transformer, not an autotransformer.

On ISF series photoelectric sensors, the power supply should be sized according to the voltage drop through the lead wire when using a long extension for the DC type (328' or 100m maximum extension).

Power Supply

The compact PS5R-A power supply is the perfect companion item for most IDEC sensors. This power supply is only 1.77" (45mm) wide, 3.15" (80mm) tall, and 2.76" (70mm) deep. Call an IDEC representative for more details.

Part Number	Output Ratings
PS5R-A12	12V DC, 0.62A
PS5R-A24	24V DC, 0.32A

Miscellaneous

Strong magnetic fields may detract from the accuracy of the sensing measurement. Avoid mounting a sensor directly to machinery, since the housing is connected to the electronic circuit ground of the sensor. If it is necessary to mount a sensor on machinery, use the insulating plate and sleeve provided.

Glossary

Attenuation: Reduction of beam intensity as a result of environmental factors such as dust, humidity, steam, etc.

Dark on: Output energized when light is *not* detected by the receiving element. For through-beam sensors, light from the projector is not detected by the receiver when an object is present. For reflected light sensors, light is not detected when it is not reflected from an object surface.

Diffuse-reflected light sensors: Sensors that detect all scattered, reflected light. Light reflected from nearby surfaces, as well as intended object surface, is detected. Diffuse-reflected light sensors are often called "proximity switches," since they switch when any object is near. Also use to detect color contrast when colors reflect light intensity differently (green LED recommended for this application).

EEPROM: Acronym which stands for electronically erasable, programmable, read only memory.

Excess gain: Ratio of optical power available at a given projector-to-receiver range divided by the minimum optical power required to trigger the receiver.

Extraneous light: Incident light received by a sensor, unrelated to the presence or absence of object being detected. Extraneous light is usually unwanted background light such as sunlight and incandescent lamps in close proximity.

ΔE: The measurement of color difference as a three-variable function, located on an XYZ axis of light, hue, and chroma values.

Hysteresis: Operating point and release point at different levels. For solid state sensors, this is accomplished electrically. For mechanical switches, it results from storing potential energy before the transition occurs.

Light on: Output energized when light is detected by receiving element. For through-beam sensors, light from the projector is detected by the receiver when an object is not present. For reflected light sensors, light is detected when it is reflected from an object surface.

Linearity: Measurement of how nearly linear, that is, how accurate actual analog output is, with respect to distance.

NPN/PNP: Types of open collector transistors. NPN is a sink transistor; output on establishes negative potential difference. PNP is a source transistor; output on establishes positive potential difference.

Polarizing: Filtering out all reflected light except that which is projected in one plane only. Polarized retro-reflected light sensors detect the light from corner-cube type reflectors when an object is not present.

Reflected-light sensors: Sensors with the projector and receiver in one housing. Light is projected by the light source, and reflected light is received by the optical surface. Includes diffuse-reflected, retro-reflected, limited-reflected, and spot-reflected sensors.

Repeatability: Ability of a sensor to reproduce output readings consistently when the same value is applied consecutively, in the same direction, for a specified number of cycles, or for a specified time duration.

Resolution: Overall dimension of the smallest object which can be detected (when sensing the presence of an object) or smallest increment of distance which can be distinguished with reliable results (when sensing the position of an object).

Response time: Time elapsed between input and output. Total response time is the sum of object detection, amplifier response, and output response times.

Retro-reflective scan: This type of reflected light sensor uses a special reflector to return projected light when an object is not present. Sensor detects the presence of an object when the light is reflected differently.

Through-beam sensors: Sensors with a separate projector and receiver. The light source from the projector is detected by the receiver, except when an object is present.

Transient: Undesirable surge of current (many times larger than normal current) for a very short period, such as during the start-up of an inductive motor.