

PRODUCT SPECIFICATION DRAWING

HOLDRITE® #121-DS

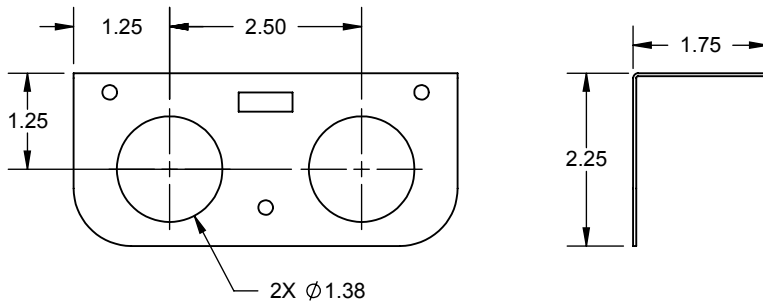
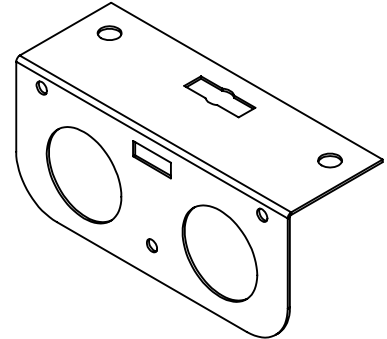
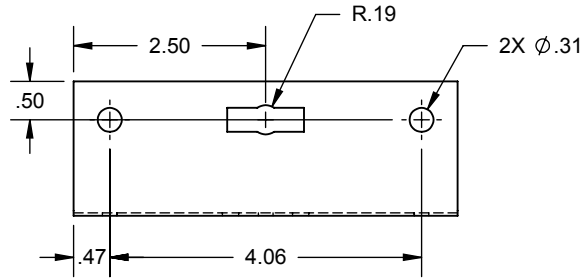

ALL DIMENSIONS IN INCHES

The **HOLDRITE® #121-DS** is a 20 gage galvanized steel bracket that supports dual lines of 1/2", 3/4" or 1" Copper, PEX or CPVC tubing at 1-1/4" center line height. The hole pattern on the 90° base allows for attachment to any flat surface. The bracket can also be suspended by 3/8" threaded rod.

Product Information:

- Material: 20 gage CRS, galvanized
- Load rating: 25 pounds
- Supports 1/2", 3/4" and 1" tubing with available inserts
- UPC / IPC / IAPMO listed



THIS INFORMATION IS PROPRIETARY TO HOLDRITE AND IS SUBJECT TO CHANGE WITHOUT NOTICE. IT MAY NOT BE REPRODUCED IN PART OR WHOLE WITHOUT WRITTEN AUTHORIZATION.



CONVERTING MAKESHIFT METHODS INTO ENGINEERED SOLUTIONSSM
 800-321-0316 OR 760-744-6944 / FAX: 760-744-0507 / WWW.HOLDRITE.COM
 spec_121-DS_RevG

Product Submittal	
Job Name:	
Date:	
Part Number:	Qty:
Architect / Owner:	
Contractor:	
Notes:	