

Installer's Guide

MODEL:

BAYCCHT101AA
BAYCCHT102AA
BAYCCHT404BA

Crankcase Heater

⚠ WARNING: HAZARDOUS VOLTAGE - DISCONNECT POWER BEFORE SERVICING

ALL phases of this installation must comply with NATIONAL, STATE AND LOCAL CODES

IMPORTANT — This Document is **customer property** and is to remain with this unit. Please return to service information pack upon completion of work.

For this Unit	Use this Heater
4WC*3018, 2WC*3024-030, 2WC*3048, 4YC*3018, 2YC*3024-030, 2YC*3042-048, 4TC*3018-024, 4WCY4024-030, 4TCY4024- 030, 4YCY4024-030, 4DCY4024-030 (230V)	BAYCCHT101AA (Reciprocating) (65 Watts)
2WC*3036-042, 2WC*3060, 4WC*3036-060, 2YC*3036, 4YC*3036-060, 2YC*3060, 4TC*3030-060, 4YCY4036-060, 4WCY4036- 060, 4TCY4036-060, 4DCY4036-060, 4WCZ6036-060, 4YCZ6036-060, 4DCZ6036-060 (230V)	BAYCCHT102AA (Scroll) (60 Watts)
4WC*3036-060, 4YC*3036-060, 4TC*3036-060, 4WCZ6036-060, 4YCZ6036-060 (460V)	BAYCCHT404BA (Scroll) (60 Watts)

⚠ WARNING

SAFETY HAZARD!

Bodily injury can result from high voltage electrical components, fast moving fans, and combustible gas. For protection from these inherent hazards during installation and service, the electrical supply must be disconnected and the main gas valve must be turned off. If operating checks must be performed with the unit operating, it is the technicians responsibility to recognize these hazards and proceed safely.

Installation

1. Set the thermostat to OFF.
2. Open all unit electrical switches.
3. Remove the unit's Control Box, Blower, and Compressor access panels.
4. Open the Crankcase Heater Kit and remove the crankcase

heater. The BAYCCHT101AA is a cartridge type and the BAYCCHT102AA and BAYCCHT404BA are the band type.

5. **Cartridge Type Crankcase Heater** - Insert the crankcase heater fully into the mating tube attached under the compressor near the electrical header.

Secure the cartridge into the tube with the spring provided in the kit. The hook end connects to the back end of the tube. The hoop end latches around the cartridge. See Figures 1 and 2.

Band Type Crankcase Heater - Place the crankcase heater band around the bottom of the compressor within 1 inch of the base. See Figure 3.

Tighten the crankcase heater around the compressor and attach the green ground wire to the base as shown. Torque heater to 20-25 inch-pounds.

7. Route the black crankcase heater leads from the Compressor compartment, through the Blower compartment, and into the Control Box compartment.
8. In the Control Box compartment, connect the leads to the

(CC) compressor contactor as shown in the diagram. Refer to Figure 4 if you have a single phase unit. Refer to Figure 5 if you have a three phase unit.

NOTE: Connect both leads on the line side of the contactor. (See Figures 4 (page 3) or 5 (page 4))

9. Secure the crankcase heater leads with wire ties. Care must be taken to ensure the leads do not come in contact with the compressor discharge line, with any moving parts, or any sharp edges.
10. Place the wiring diagram provided with the kit on the inside of the Control Box access panel.
11. Reinstall the Compressor, Blower, and Control Box access panels.
12. Reapply power to the unit.
13. The crankcase heater should immediately begin to heat. The crankcase heater will heat at all times.
14. Reset the thermostat.

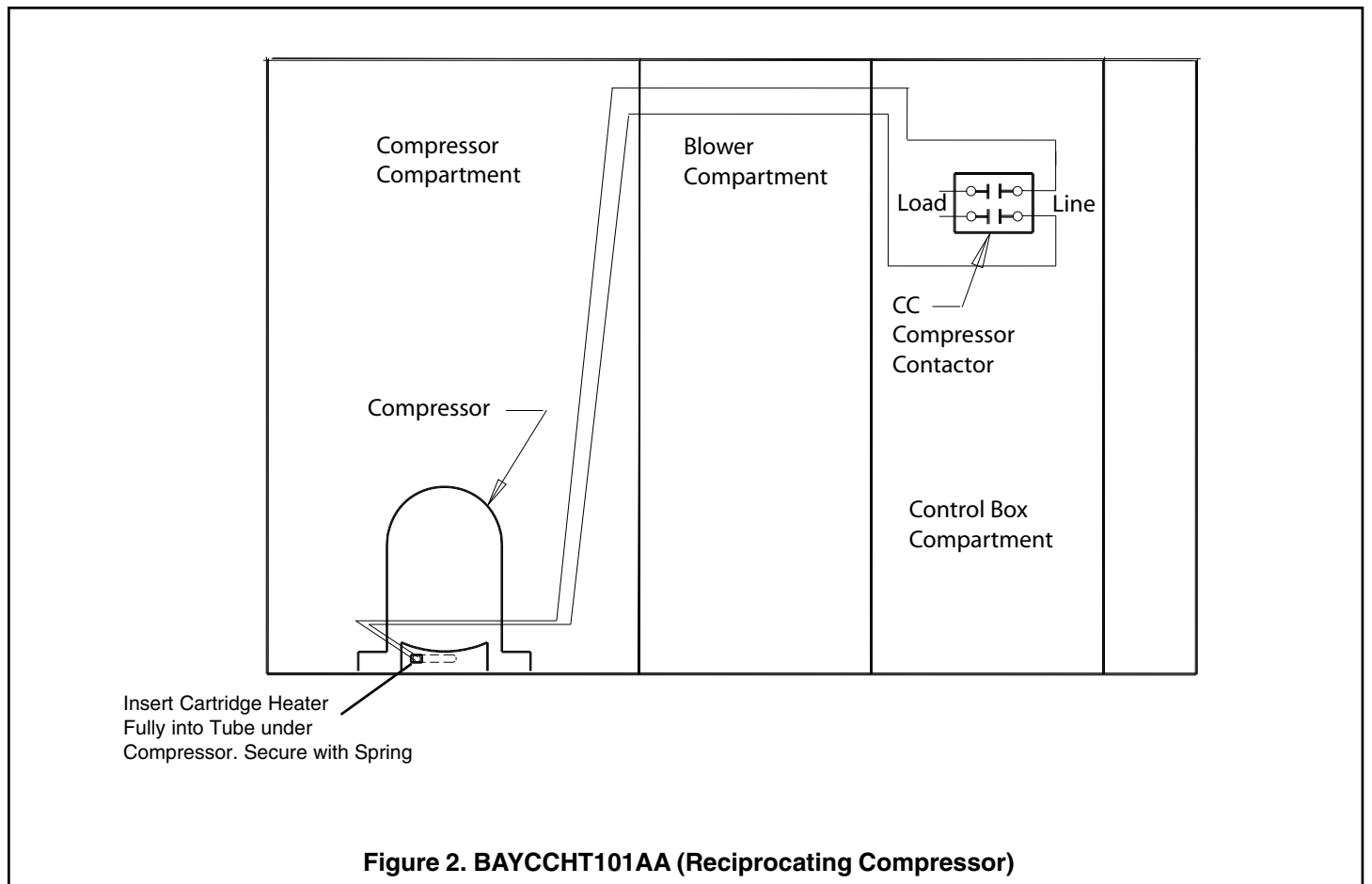
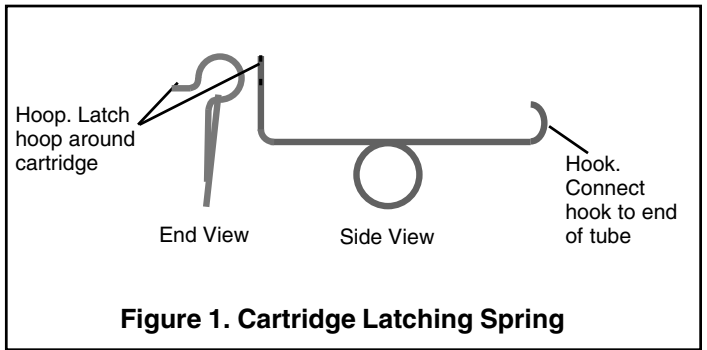

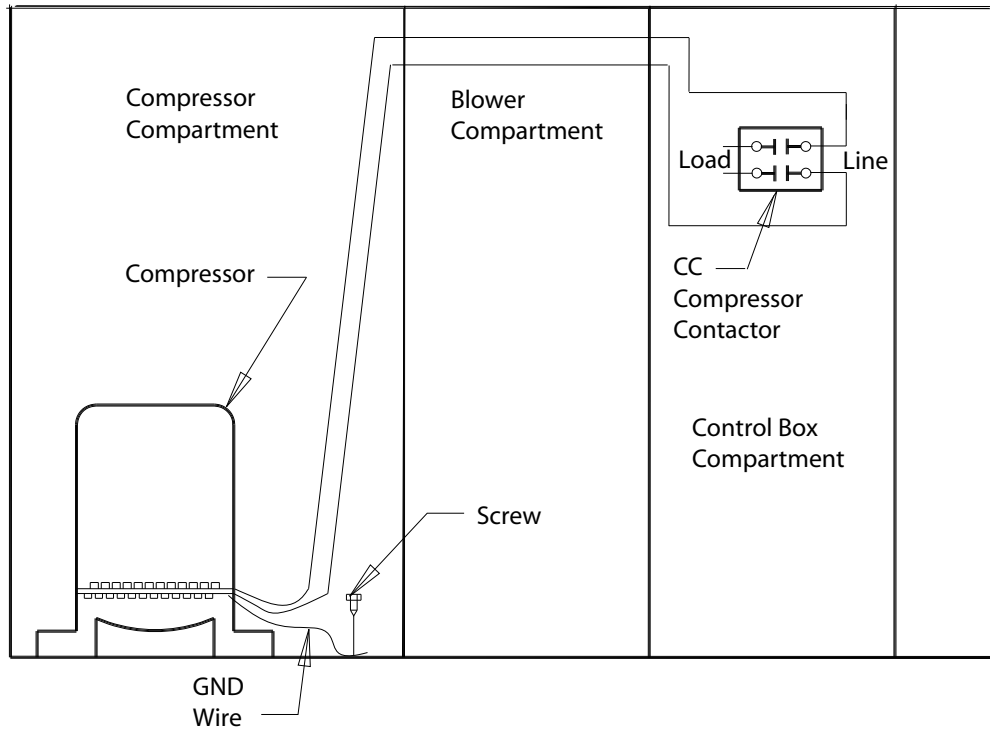

Figure 3. BAYCCHT102AA and BAYCCHT404BA (Scroll Compressor)

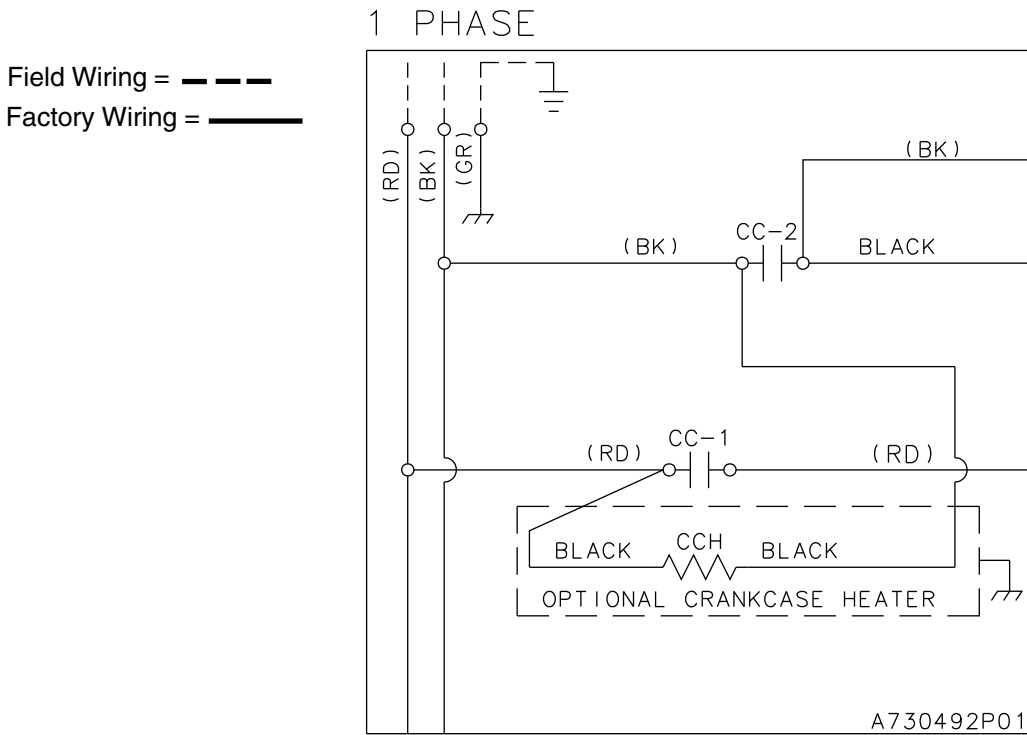

Figure 4. Single Phase Wiring

3 PHASE

Field Wiring = - - - -
Factory Wiring = _____

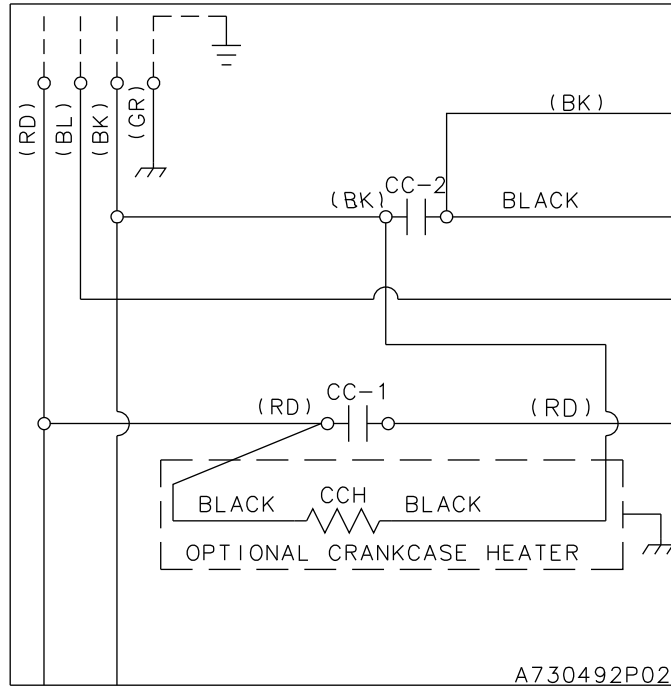

Figure 5. Three Phase Wiring