



Eliminator[®]

Deep Vacuum Pump

OPERATING INSTRUCTIONS & PARTS MANUAL

TM 2-Stage, Direct Drive

Specifications

Models DV-3E, DV-4E, DV-6E

MOTOR

1/2 HP, 60 HZ, 1725 RPM; Capacitor start; Automatic thermal overload protected.

INTAKE PORTS

1/4 x 3/8 Male Flare

FREE AIR DISPLACEMENT

CFM	Liters Per Minute
3	85
4	113
6	170

Models

DV-3E-250, DV-4E-250, DV-6E-250

MOTOR

1/2 HP, Dual Cycle, 50/60 HZ, 1425/1725 RPM; Capacitor start; Automatic thermal overload protected.

INTAKE PORTS

1/4 x 3/8 Male Flare

FREE AIR DISPLACEMENT

CFM	50 HZ		60 HZ	
	Liters Per Minute	CFM	Liters Per Minute	CFM
2.5	71	3	85	
3.3	95	4	113	
4.95	142	6	170	

In order to make the best use of your investment, familiarize yourself with the new features and operating instructions before starting pump. With just routine care your **Eliminator** will give you years of reliable service by following proper maintenance guidelines. **Eliminator pumps are designed for deep vacuum work in Air Conditioning and Refrigeration Systems.**

IMPORTANT: Use oil specifically refined for deep vacuum pumps. Using oil not refined for deep vacuum pumps and/or operating with contaminated oil will void warranty.



NOTE: Eliminator[®] pumps are not to be used on Ammonia or Lithium Bromide (salt water) systems. Pump maintenance is the responsibility of the owner.

Each **Eliminator** pump has been factory tested to guarantee 25 micron or better and listed CFM performance. The serial number has been recorded. Complete and mail the Warranty Registration Card within 10 days of purchase to validate your warranty. You will be notified of any technical updates.

25,400 Microns = 1"

IMPORTANT

**This unit has been drained for shipment.
DO NOT ATTEMPT
TO OPERATE WITHOUT ADDING OIL.**

OIL CAPACITY

Being just a teaspoon low affects the ultimate vacuum.

Model DV-3E
24.5 oz.

Models DV-4E & DV-6E
22.5 oz.

Slowly add oil until oil level rises even with arrows on front of cover. Replace oil fill plug.

If oil is too low, you will hear air out of the exhaust. If the oil level is too high, excess oil will be blown out the exhaust.

Pump oil should be changed after each use. If system is heavily contaminated, oil may have to be changed several times during evacuation.

After initial fill up, best to check oil level with pump running.



OPERATION

IMPORTANT

DO NOT START PUMP BEFORE ADDING OIL

The following procedures will prevent oil from being drawn into cartridge and creating hard start-up.

START-UP

Close both sides of manifold and make connection to vacuum pump or auxiliary blank-off equipment. Start pump.

SHUT-DOWN

Crack open unused port to break vacuum. Allow pump to run 2-3 seconds. Shut down and remove hose connections and cap intakes.

CHANGING OIL

To reach deep vacuum, Eliminator pumps need clean, moisture-free oil throughout evacuation.

Care should be taken to avoid contact on skin and clothing when changing oil. Used oil should be disposed of in a leakproof corrosive-resistant container.

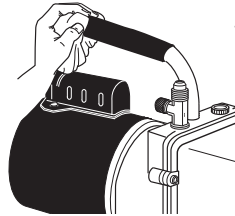

1. After every evacuation while pump is warm and oil is thin, place pump on level surface and open oil drain. Oil can be forced from the pump by opening one intake and partially blocking the exhaust with a cloth while the pump is running. Do not operate the pump for more than 5 minutes using this method.
2. Slowly add oil until oil level rises even with arrows on front of cover. Replace oil fill plug.

After Evacuation, Oil Contains Rust Forming Water and Corrosive Acids. Drain Immediately While Pump Is Warm.



FLUSHING

If the oil is badly contaminated, flushing may be necessary. Slowly pour 1/3–1/2 cup of fresh JB vacuum pump oil into the intake connection while pump is running. Repeat as required until contamination is removed from oil reservoir, pump rotors, vanes and housing. Dispose of all oil used in flushing of pump.

Deep Vacuum Accessories

Designed for all pumps without internal blankoff valve to isolate pump from system.

D10162 SHUT-OFF VALLVE

1/4" FE QC x 1/4" Flare

O-ring quick coupler valve excellent for blanking off any vacuum system. Excellent for pressure up 500 lbs.

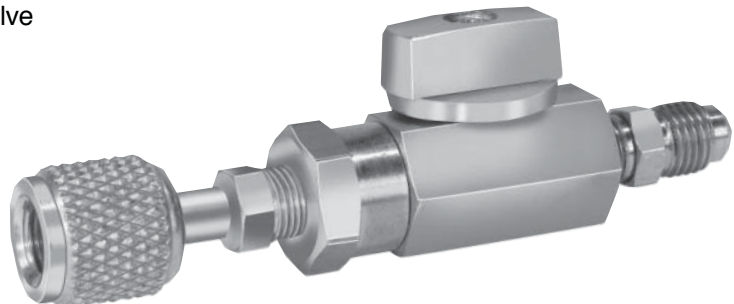

Check our website at www.jbind.com for more product information and download the article "Deep Vacuum Principles" under "Technical Information"

REPAIR PARTS

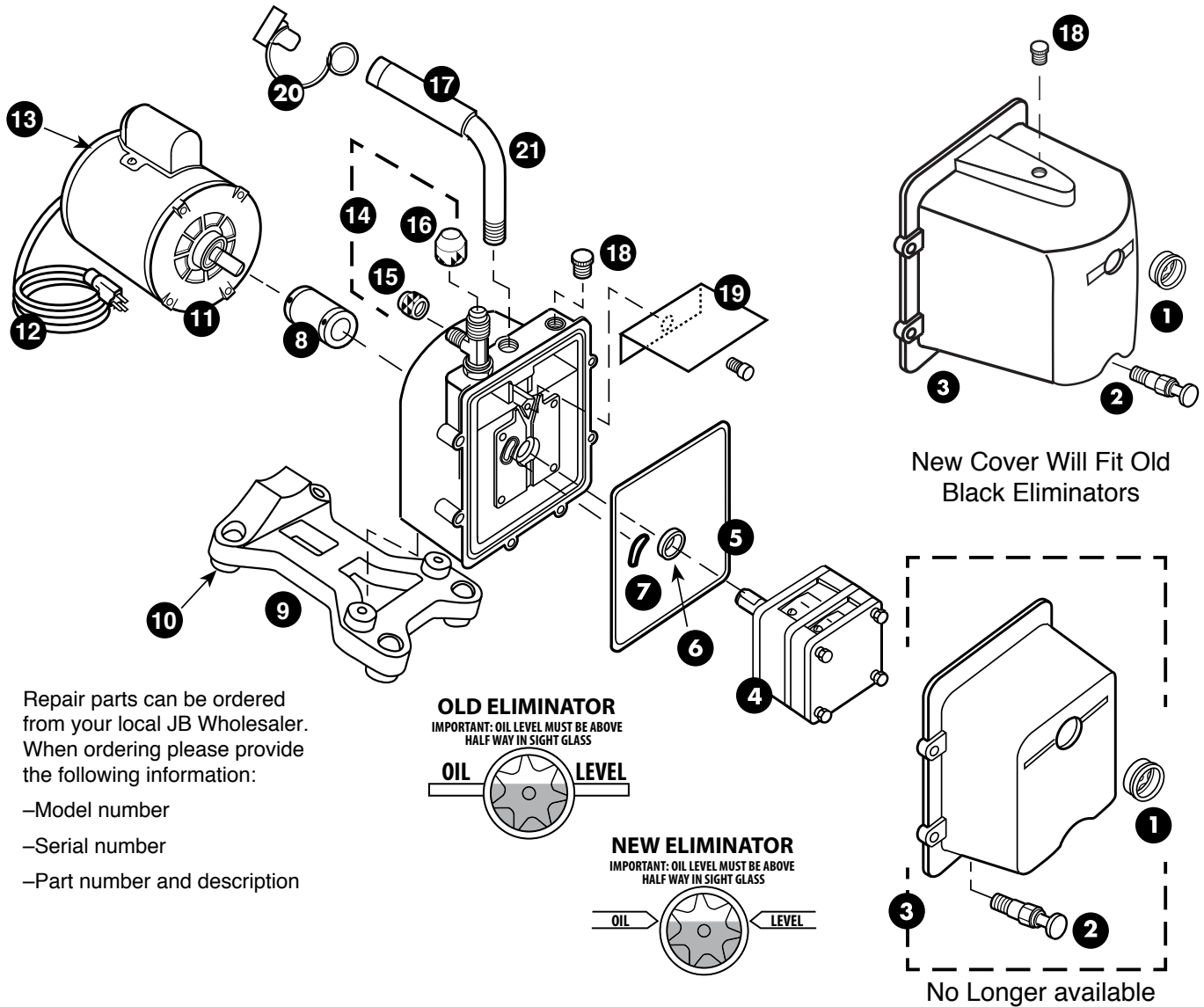

Repair parts can be ordered from your local JB Wholesaler. When ordering please provide the following information:

- Model number
- Serial number
- Part number and description

OLD ELIMINATOR
IMPORTANT: OIL LEVEL MUST BE ABOVE HALF WAY IN SIGHT GLASS

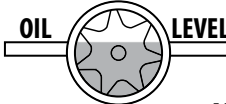

NEW ELIMINATOR
IMPORTANT: OIL LEVEL MUST BE ABOVE HALF WAY IN SIGHT GLASS

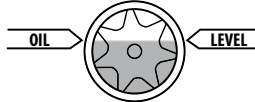

REF. NO.	PART NO.	DESCRIPTION
1	PR-1♦	Sight Glass
2	PR-2♦	Drain Valve
3	PR-10	Cover Assy. Includes Sight Glass and Drain Valve
4	PR-403	DV-3E Cartridge Complete w/O-Rings and Cover Seal
	PR-404	DV-4E Cartridge Complete w/O-Rings and Cover Seal
	PR-406	DV-6E Cartridge Complete w/O-Rings and Cover Seal
5	PR-217	Cover Seal
6	PR-3	Shaft Seal
7	PR-315	Trap Intake O-Ring
8	PR-20♦	Flexible Coupler (3 Parts)
	PR-308	Flexible Section Only
9	PR-62	Pump Base (Includes Rubber Feet)
10	PR-59	Pump Feet (Qty 2)

REF. NO.	PART NO.	DESCRIPTION
11	PR-206	1/2 HP, 115V Motor 60HZ w/Line Cord
	PR-207	1/2 HP, 115/230V, 50/60 HZ Motor w/Line Cord
12	PR-31	6' Line Cord 115V Emerson Motor
	PR-58	6' Line Cord 115V Marathon Motor
13	PR-54	Rocker-Switch 115V Emerson Motor (Wire Leads)
	PR-35	Rocker-Switch 115V Marathon Motor (Prongs)
14	PR-63♦	Intake Tee with With O-Ring
15	NFT5-4	1/4" O-Ring Cap
16	NFT5-6	3/8" O-Ring Cap
17	PR-205♦	Cushioned Handle With Cap End
18	PR-22	Oil Fill Plug With O-Ring
19	PR-40	Splash Guard with Screw
20	DV-EP-6 101	3/8" Red Plug For Handle on Black Eliminator
	DV-EP-8 101	1/2" Red Plug For Handle on New Grey Eliminator
21	PR-205	Handle With Cushion Grip And End Cap

Not Shown

* PR-18 Cartridge Valve Repair Kit (Not Shown)

♦ Coat with thread sealant when replacing

TROUBLESHOOTING CHART

Symptom	Possible Cause(s)	Corrective Action
Pump won't start.	<ol style="list-style-type: none"> 1. Power cord not plugged in securely. 2. Motor switch not on. 3. Pump temp. below 30°F. 4. Inconsistent line voltage. 	<ol style="list-style-type: none"> 1. Plug power cord in securely. 2. Turn motor switch to ON position. 3. Warm up pump to 30°F & turn motor switch on. 4. Line voltage must be within 10% of 115 volt.
Pump won't pull deep vacuum.	<ol style="list-style-type: none"> 1. Contaminated oil. 2. Oil level too low. 3. Air leak in system being evacuated. 4. Pump inlet fittings missing or not tightened. 5. Coupler slipping 	<ol style="list-style-type: none"> 1. Change oil. 2. Add oil. 3. Locate & repair leaks. 4. Clean or replace O-ring. 5. Tighten coupler setscrews to flats of cartridge and motor.
Oil drips from point where shaft enters the pump housing.	Damaged oil seal.	Replace.
Pump shuts down and will not start.	Thermal overload may be open.	Disconnect pump from system. Wait about 15 minutes for motor to cool and turn it on again. If it cycles off again, return pump to factory for repair.
Pump cycles on and off from a completely cold start and then runs smoothly.	Oil backed up into cartridge and was being cleared out. Pump has not been shutdown properly.	<ol style="list-style-type: none"> 1. Remove 1/4" cap. 2. Turn pump on.

PUMP MOTOR

Pump and oil must be above 30°F. Line voltage must be equal to motor nameplate $\pm 10\%$. Normal operating temperature is approximately 160°F, which is hot to the touch. Line voltage and ambient conditions will affect this somewhat. Motor has automatic resetting thermal overload protection. **Eliminator** is designed for continuous duty and will run for extended periods without overheating.

WARRANTY

Eliminator pumps are warranted against defects in materials and workmanship for 2 years. All JB products are guaranteed when used in accordance with our directions and recommendations, and we limit this warranty to the repair, replacement, or credit at invoice price (our option) of products which in our opinion are defective due to defects in workmanship and/or materials. In no case will we allow charges for labor, expense or consequential damage. Repairs performed on items out of warranty will be invoiced on a nominal basis. Contact your wholesaler for details.

Should you need further assistance, write our Home Office or contact your nearest JB Service Center.

JB INDUSTRIES, INC.
P.O. Box 1180—Dept. 85
Aurora, Illinois 60507-1180 USA
E-mail: sales@jbind.com
Visit our web site at: www.jbind.com
Toll Free Technical Service
Number 1-800-323-0811

