

FNW1241/FNW1242

CHECK VALVES



BRONZE SWING CHECK VALVES

The FNW Swing Check Valves listed and covered in these instructions are bronze valves made of ASTM B62 material for class 150 valves with PTFE seat types. Check Valves are used in systems that need flow to move in one direction. An arrow on the side of the valve indicates the flow direction. If the flow reverses, the disc in the valve will swing shut, blocking the back-flow. Swing check valves produce the lowest pressure drop compared to other check valves of the same size. They have a leakage rate of 40ml per inch of diameter per hour, in accordance with MSS-SP-80.

TABLE OF CONTENTS

Standard Materials 2

Pressure Ratings..... 3

Pressure Ratings..... 4

Maintenance 4

Warranty 5



Fig. 1241



Fig. 1242

Model	Size Range	Description
Fig. 1241	1/2"-3"	Class 150 PTFE Disc NPT end
Fig. 1242	1/2"-2"	Class 150 PTFE Disc Solder end

FNW1241/FNW1242

CHECK VALVES



BRONZE SWING CHECK VALVES

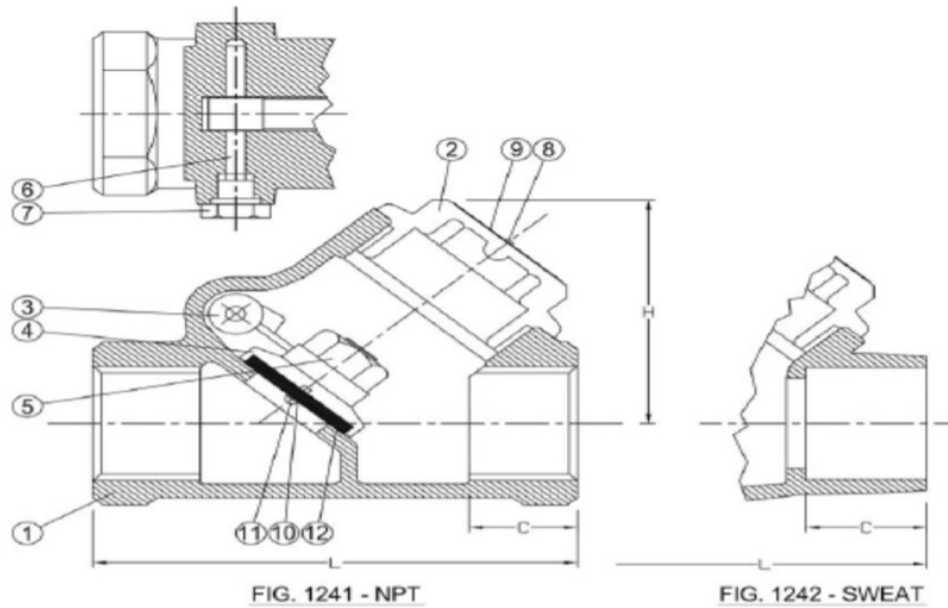

STANDARD MATERIALS REFERENCE TABLE

Ref. No	Description	Material
1	Body	Bronze ASTM B62 C83600
2	Cap	Bronze ASTM B62 C83600
3	Hanger	Bronze ASTM B62 C83600
4	Disc	Bronze ASTM B62 C83600
5	Hanger Nut	Brass ASTM B16 C36000
6	Hanger Pin	Brass ASTM B16 C36000
7	Side Plug	Brass ASTM B16 C36000
8	Rivert	Mild Steel
9	Name Plate	Aluminum
10	Washer	Brass ASTM B16 C36000
11	Screw	Brass ASTM B16 C36000
12	Disc	PTFE

FNW1241/FNW1242

CHECK VALVES



BRONZE SWING CHECK VALVES

PRESSURE RATING

These ratings are the maximum allowable, non-shock pressures at the temperatures shown in the table below. All valves are 100% shell and seat tested at an air pressure of 80 psi in accordance with MSS-SP-80 requirements.

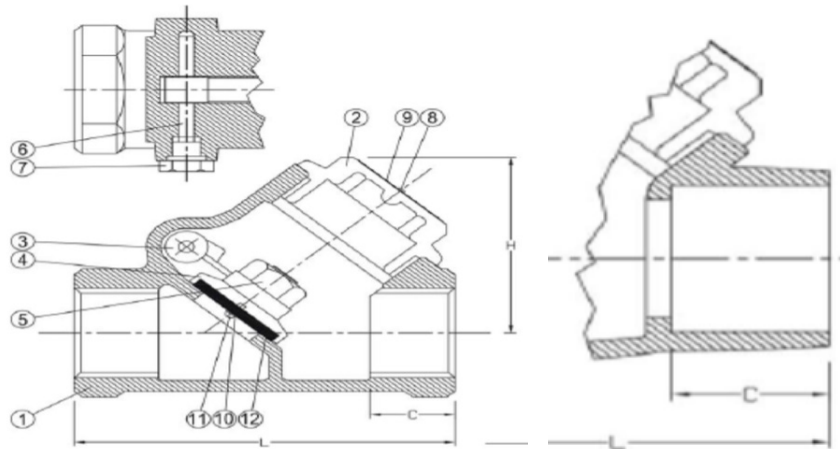

Fig. 1241

Fig. 1242

FIG. 1241-NPT END CONNECTION

Working Pressure							
Working Pressure Non-Shock (psi)		Test Pressure (psi)		Working Pressure Non-shock (kPa)		Test Pressure (kPa)	
Saturated Steam	Cold Water, Oil, Gas	Shell (Air)	Seat (Water)	Saturated Steam	Cold Water, Oil, Gas	Shell (Air)	Seat (Water)
150	300	80	50	1034	2068	551	344

FIG. 1242-SOLDER END CONNECTION

Working Pressure									
Service Temperature		Working Pressure Non-Shock (psi)		Test Pressure (psi)		Working Pressure Non-shock (kPa)		Test Pressure (kPa)	
Fahrenheit	Celcius	1/2" ~ 1"	1-1/2" ~ 2"	Shell (Air)	Seat (Water)	1/2" ~ 1"	1-1/2" ~ 2"	Shell (Air)	Seat (Water)
100	38	500	400	80	50	3447	2757	550	345
150	65	400	350	80	50	2757	2413	550	345
200	93	300	250	80	50	2068	1723	550	345
250	121	200	175	80	50	1379	1206	550	345

FNW1241/FNW1242

CHECK VALVES



BRONZE SWING CHECK VALVES

INSTALLATION

Preparation

- Make sure the valve is suitable for the pressure, temperature and service conditions.
- Make sure the threads of the mating pipe are clean and machined to the appropriate ANSI/ASME specifications.
- Make sure the ends of the mating pipe are free of burrs.
- Use a cloth to clean and remove grease before soldering.
- Make sure the sealing surfaces of the valve are clean.

Installation

The swing check valve should be installed in a horizontal position with the flow arrow in the direction of flow and covered on the top. It is not suggested installation occurs close to reciprocating pumps or compressors as the constant fluctuations shorten the life of the valve.

NPT End Connection

- Gently thread the swing check valve (in the closed position) to the mating pipe by hand until resistance is felt.
- Use a wrench to tighten the valve end at the mating joint. Do not tighten the screws opposite the mating joint through the valve body.



WARNING:

Ensure that the valve is not overtightened to cause valve malfunction or leakage at the joint. Shut off all operating lines to the valve site.

Solder End Connection

- Install the check valve with disc in the open position.
- Do not overheat the valve or allow solder to flow into the valve opening.
- Direct flame away from the valve body, concentrating on the solder cup and heating it evenly.



WARNING:

Excessive heat input will damage the body seal resulting in leaks at the valve body joint.



WARNING:

Do not use Swing Check Valve as foot valve on a pump or pressure regulation devices.

MAINTENANCE

If this valve leaks, check the end connection at the mating joint. This valve should be replaced if leaking, instead of attempting to repair.

FNW1241/FNW1242

CHECK VALVES



BRONZE SWING CHECK VALVES

WARRANTY

- 1.1 **LIMITED WARRANTY:** Subject to the limitations expressed herein, Seller warrants that products manufactured by Seller shall be free from defects in design, material and workmanship under normal use for a period of one (1) year from installation but in no case shall the warranty period extend longer than eighteen months from the date of sale. This warranty is void for any damage caused by misuse, abuse, neglect, acts of God, or improper installation. For the purpose of this section, "Normal Use" means in strict accordance with the installation, operation and maintenance manual. The warranty for all other products is provided by the original equipment manufacturer.
- 1.2 **REMEDIES:** Seller shall repair or replace, at its option, any non-conforming or otherwise defective product, upon receipt of notice from Buyer during the Manufacturer's warranty period at no additional charge. SELLER HEREBY DISCLAIMS ALL OTHER EXPRESSED OR IMPLIED WARRANTIES, INCLUDING, WITHOUT LIMITATION, ALL IMPLIED WARRANTIES OF MERCHANTABILITY AND FITNESS OR FITNESS FOR A PARTICULAR PURPOSE.
- 1.3 **LIMITATION OF LIABILITY:** UNDER NO CIRCUMSTANCES SHALL EITHER PARTY BE LIABLE TO THE OTHER FOR INCIDENTAL, PUNITIVE, SPECIAL OR CONSEQUENTIAL DAMAGES OF ANY KIND. BUYER HEREBY ACKNOWLEDGES AND AGREES THAT UNDER NO CIRCUMSTANCES, AND IN NO EVENT, SHALL SELLER'S LIABILITY, IF ANY, EXCEED THE NET SALES PRICE OF THE DEFECTIVE PRODUCT(S) PURCHASED DURING THE PREVIOUS CONTRACT YEAR.
- 1.4 **LABOR ALLOWANCE:** Seller makes NO ADDITIONAL ALLOWANCE FOR THE LABOR OR EXPENSE OF REPAIRING OR REPLACING DEFECTIVE PRODUCTS OR WORKMANSHIP OR DAMAGE RESULTING FROM THE SAME.
- 1.5 **RECOMMENDATIONS BY SELLER:** Seller may assist Buyer in selection decisions by providing information regarding products that it manufactures and those manufactured by others. However, Buyer acknowledges that Buyer ultimately chooses the product's suitability for its particular use, as normally signified by the signature of Buyer's technical representative. Any recommendations made by Seller concerning the use, design, application or operation of the products shall not be construed as representations or warranties, expressed or implied. Failure by Seller to make recommendations or give advice to Buyer shall not impose any liability upon Seller.

EXCUSED PERFORMANCE: Seller will make a good faith effort to complete delivery of the products as indicated by Seller in writing, but Seller assumes no responsibility or liability and will accept no back-charge for loss or damage due to delay or inability to deliver, caused by acts of God, war, labor difficulties, accidents, inability to obtain materials, delays of carriers, contractors or suppliers or any other causes of any kind whatever beyond the control of Seller. Under no circumstances shall Seller be liable for any special, consequential, incidental, or indirect damages, losses, or expense (whether or not based on negligence) arising directly or indirectly from delays or failure to give notice of delay.